

SMD Aluminum Electrolytic Capacitors



FEATURES

- Polarized aluminum electrolytic capacitors, non-solid electrolyte
- SMD version with base plate, vertical construction, requiring minimum board space
- High CV per unit volume
- Ø 4 mm to Ø 18 mm, 105 °C, 2000 h endurance
- Material categorization: for definitions of compliance please see www.vishay.com/doc?99912

RoHS
COMPLIANT

APPLICATIONS

- SMD technology
- Coupling, decoupling, smoothing, filtering, buffering, timing
- Telecommunications, general industrial, EDP, portable and lightweight equipment

QUICK REFERENCE DATA

DESCRIPTION	UNIT	VALUE	
Nominal case sizes (Ø D)	mm	4 x 5.7 to 18 x 21.5	
Rated capacitance range	µF	0.22 to 8200	
Capacitance tolerance	%	± 20 (at 120 Hz, 20 °C)	
Rated voltage range	V _{DC}	6.3 to 100	160 to 450
Category temperature range	°C	-55 to +105	-40 to +105
Endurance	h	2000	
Shelf life	h	1000	

ORDERING INFORMATION

Part number example: GSC00BX2211HARL

<u>GSC</u>	<u>00</u>	<u>BX</u>	<u>221</u>	<u>1H</u>	<u>AR</u>	<u>L</u>
SERIES NAME	DESIGN / FORMING	DIMENSIONS	CAPACITANCE	VOLTAGE	PACKING	INTERNAL CODE
		See "Dimensions" table	See "Selection Chart"	See "Selection Chart"	Tape and Reel	

ADDITIONAL ELECTRICAL DATA

LEAKAGE CURRENT (Test conditions: U_R , 20 °C)			
RATED VOLTAGE	TIME	CASE SIZE	VALUE
6.3 V to 100 V	after 2 min	Ø 4 mm to Ø 10 mm	$I = 0.01 CV$ or 3 μA , whichever is greater
		Ø 12.5 mm to Ø 18 mm	$I = 0.03 CV$ or 4 μA , whichever is greater
160 V to 450 V	after 5 min	Ø 12.5 mm to Ø 18 mm	$I = 0.04 CV + 100 \mu A$

Notes

- Where, C = rated capacitance in μF
- V = rated DC working voltage in V

DISSIPATION FACTOR ($\tan \delta$ at 120 Hz, 20 °C)										
RATED VOLTAGE	6.3	10	16	25	35	50	63	100	160 TO 250	400 TO 450
Ø 4 mm to Ø 10 mm	0.45	0.35	0.28	0.18	0.16	0.14	0.12	0.12	-	-
Ø 12.5 mm to Ø 18 mm	0.40	0.38	0.34	0.26	0.22	0.18	0.14	0.10	0.20	0.25

Note

- When the capacitance exceeds 1000 μF , 0.02 shall be added every 1000 μF increase.

LOW TEMPERATURE BEHAVIOR (at 120 Hz)											
IMPEDANCE RATIO	CASE SIZE	RATED VOLTAGE									
		6.3	10	16	25	35	50	63	100	160 TO 250	400 TO 450
$\frac{Z_{(-25\text{ °C})}}{Z_{(+20\text{ °C})}}$	Ø D < 12.5 mm	4	4	3	2	2	2	2	3	-	-
	Ø D ≥ 12.5 mm	5	4	3	2	2	2	2	2	3	6
$\frac{Z_{(-55\text{ °C or } -40\text{ °C})}}{Z_{(+20\text{ °C})}}$	Ø D < 12.5 mm	12	8	6	4	3	3	3	4	-	-
	Ø D ≥ 12.5 mm	10	8	6	4	3	3	3	3	6	10

MULTIPLIER OF RIPPLE CURRENT AS A FUNCTION OF FREQUENCY		
FREQUENCY (Hz)	CAPACITANCE (μF)	
	< 1000	1000 < C ≤ 4700
50	0.80	0.85
120	1.00	1.00
1000	1.25	1.15
10 000 and up	1.40	1.25

TEST PROCEDURES AND REQUIREMENTS				
TEST	TEST TIME	CAPACITANCE CHANGE	DISSIPATION FACTOR	LEAKAGE CURRENT
Endurance ⁽¹⁾	2000 h	Within ± 25 % of initial value for Ø ≤ D 6.3 mm; within ± 20 % of initial value for Ø ≥ D 8 mm	Less than 300 % of specified value for Ø ≤ D 6.3 mm; less than 200 % of specified value for Ø ≥ D 8 mm;	Within specified value
Shelf life ⁽²⁾	1000 h			

Notes

- ⁽¹⁾ The specifications shall be satisfied when the capacitors are restored to 20 °C after the rated voltage applied for 2000 h at 105 °C.
⁽²⁾ The rated voltage shall be applied to the capacitors before measurements for 160 V to 450 V (refer to JIS C 5101-44.1).

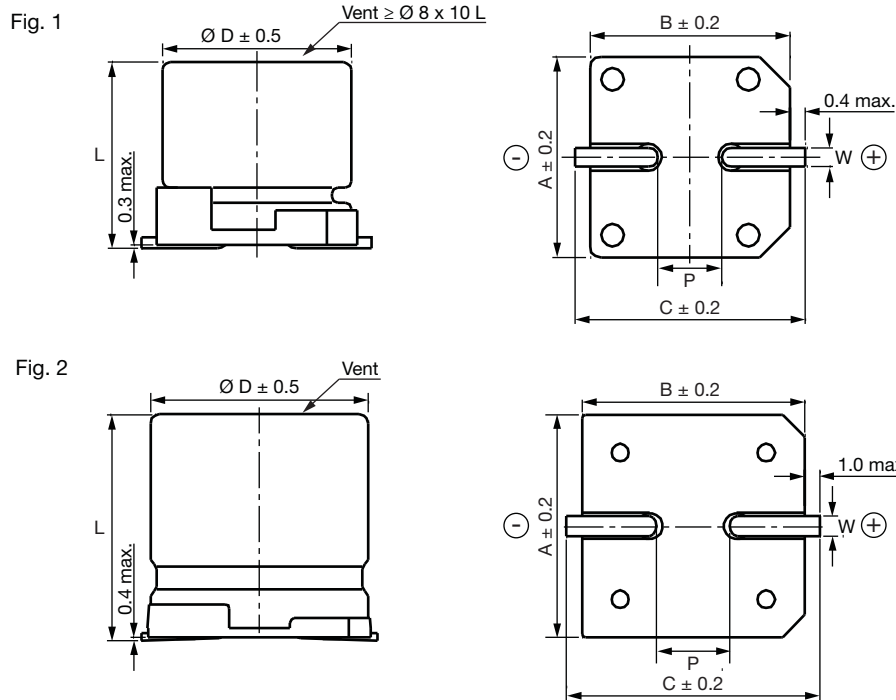
DIMENSIONS in millimeters

CASE SIZE CODE	Ø D	L	A	B	C	W	P ± 0.2	FIG. NO.
AB	4 x 5.7	4	5.7 ± 0.3	4.3	4.3	5.1	1.0	1
AC	5 x 5.7	5	5.7 ± 0.3	5.3	5.3	5.9	1.5	1
AD	6.3 x 5.7	6.3	5.7 ± 0.3	6.6	6.6	7.2	2.0	1
BM	6.3 x 7.7	6.3	7.7 ± 0.3	6.6	6.6	7.2	2.0	1
AE	8 x 6.5	8	6.5 ± 0.3	8.4	8.4	9.0	2.3	1
AF	8 x 10	8	10 ± 0.5	8.4	8.4	9.0	3.1	1
XM	10 x 7.7	10	7.7 ± 0.3	10.4	10.4	11.0	4.7	1
AG	10 x 10	10	10 ± 0.5	10.4	10.4	11.0	4.7	1
AH	12.5 x 13.5	12.5	13.5 ± 0.5	13	13	13.7	4.4	2
CX	12.5 x 16	12.5	16 ± 0.5	13	13	13.7	4.4	2
AK	16 x 16.5	16	16.5 ± 0.5	17	17	18.0	6.4	2
AM	16 x 21.5	16	21.5 ± 0.5	17	17	18.0	6.4	2
AN	18 x 16.5	18	16.5 ± 0.5	19	19	20.0	6.4	2
AP	18 x 21.5	18	21.5 ± 0.5	19	19	20.0	6.4	2

MARKING

Ø D ≤ 6.3 mm

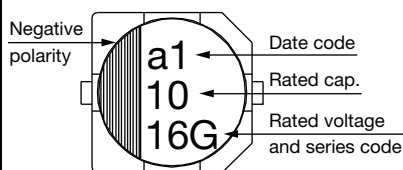

Ø D = 8 mm to 10 mm

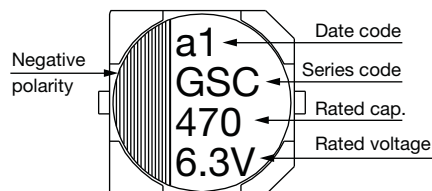

Ø D ≥ 12.5 mm

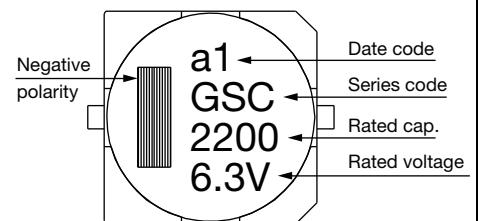



SELECTION CHART, DIMENSIONS, AND PERMISSIBLE RIPPLE CURRENT (at 120 Hz / 105 °C)															
V_{DC}		6.3 (0J)		10 (1A)		16 (1C)		25 (1E)		35 (1V)		50 (1H)		63 (1J)	
CAP.	CODE	Ø D x L	mA	Ø D x L	mA	Ø D x L	mA	Ø D x L	mA	Ø D x L	mA	Ø D x L	mA	Ø D x L	mA
1.0	010											4 x 5.7	8	4 x 5.7	8
2.2	2R2											4 x 5.7	12	4 x 5.7	12
3.3	3R3											4 x 5.7	14	5 x 5.7	17
4.7	4R7							4 x 5.7	17	4 x 5.7	17	5 x 5.7	20	6.3 x 5.7	22
10	100					4 x 5.7	20	4 x 5.7	20	5 x 5.7	27	6.3 x 5.7	32	6.3 x 5.7 8 x 6.5	32 51
22	220	4 x 5.7	22	4 x 5.7	22	5 x 5.7	30	5 x 5.7	30	6.3 x 5.7	44	6.3 x 5.7 8 x 6.5	38 67	6.3 x 7.7	58
33	330	5 x 5.7	34	5 x 5.7	34	5 x 5.7	34	6.3 x 5.7	46	6.3 x 5.7 8 x 6.5	46 76	6.3 x 7.7	65	8 x 10	140
47	470	5 x 5.7	38	5 x 5.7	38	6.3 x 5.7	48	6.3 x 5.7 8 x 6.5	48 79	6.3 x 7.7	80	6.3 x 7.7	70	8 x 10	170
100	101	6.3 x 5.7	69	6.3 x 5.7 8 x 6.5	69 90	6.3 x 5.7	69	6.3 x 7.7	100	8 x 10	240	8 x 10	210	10 x 10	310
220	221	6.3 x 7.7 8 x 6.5	120	6.3 x 7.7	120	6.3 x 7.7	120	8 x 10 10 x 7.7	270	8 x 10	270	10 x 10	330	12.5 x 13.5	470
330	331	8 x 10	290	8 x 10	290	8 x 10 10 x 7.7	290	8 x 10	290	10 x 10	370	12.5 x 13.5	490	16 x 16.5	650
470	471	8 x 10	320	8 x 10 10 x 7.7	320	10 x 10	380	10 x 10	380	12.5 x 13.5	520	12.5 x 16	550	16 x 16.5	700
1000	102	10 x 10	410	10 x 10	410	12.5 x 13.5	550	12.5 x 16	550	16 x 16.5	800	18 x 16.5	990		
2200	222	12.5 x 13.5	680	12.5 x 13.5	680	16 x 16.5	900	16 x 16.5	900	18 x 16.5	1050				
3300	332	12.5 x 16	850	16 x 16.5	950	16 x 16.5	950	18 x 16.5 16 x 21.5	1150 1200						
4700	472	16 x 16.5	1000	16 x 16.5	1000	18 x 16.5 16 x 21.5	1225 1275	18 x 21.5	1300						
6800	682	18 x 16.5 16 x 21.5	1290 1350	18 x 16.5 16 x 21.5	1290 1350										
8200	822	18 x 21.5	1450	18 x 21.5	1450										

SELECTION CHART, DIMENSIONS, AND PERMISSIBLE RIPPLE CURRENT (at 120 Hz / 105 °C)													
V_{DC}		100 (2A)		160 (2C)		200 (2D)		250 (2E)		400 (2G)		450 (2W)	
CAP.	CODE	Ø D x L	mA	Ø D x L	mA	Ø D x L	mA	Ø D x L	mA	Ø D x L	mA	Ø D x L	mA
4.7	4R7							12.5 x 13.5	65	12.5 x 13.5	45	12.5 x 13.5	45
10	100					12.5 x 13.5	80	12.5 x 13.5	70	12.5 x 13.5	50	12.5 x 16	75
22	220	8 x 10	100			12.5 x 16	110	12.5 x 13.5	105	16 x 16.5	85	16 x 16.5	85
33	330	10 x 10	150	12.5 x 13.5	95	12.5 x 16	120	16 x 16.5	180	18 x 16.5	100	18 x 16.5	100
47	470	12.5 x 13.5	250	16 x 16.5	240	16 x 16.5	220	16 x 16.5	220	18 x 21.5	130		
100	101	12.5 x 13.5	380	16 x 16.5	250	18 x 16.5	280	18 x 16.5	260				
220	221	16 x 16.5	450										
330	331	18 x 16.5 16 x 21.5	590 750										
470	471	18 x 21.5	980										
1000	102												
2200	222												
3300	332												
4700	472												
6800	682												

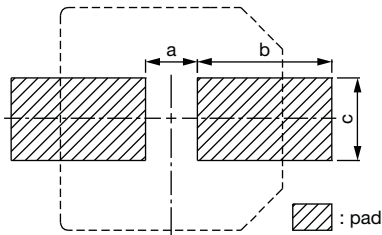
SOLDERING

Recommended soldering pad dimensions

RECOMMENDED SOLDERING PAD DIMENSIONS in millimeters			
CASE SIZE (\emptyset)	LAND SIZE		
	a	b	c
3	0.8	2.2	1.6
4	1.0	2.6	1.6
5	1.4	3.0	1.6
6.3	1.9	3.5	1.6
8 x 6.5	2.1	4.0	1.6
8	3.0	3.5	2.5
10	4.0	4.0	2.5
12.5	4.0	6.0	3.2
16	6.0	7.0	3.2
18	6.0	8.0	3.2

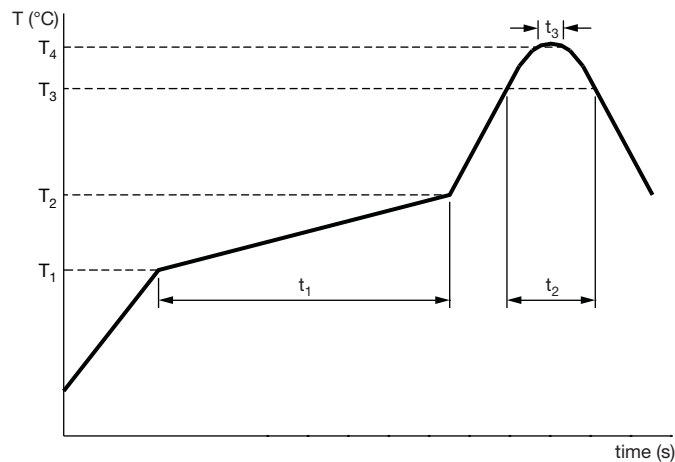
STANDARD SOLDERING PROFILE FOR LEAD (Pb)-FREE REFLOW PROCESS

Maximum temperature load during reflow soldering

REFLOW SOLDERING CONDITIONS					
Rated voltage (V)	4 to 50	4 to 50	63 and up	4 and up	
Case size (\emptyset)	4 to 6.3 x 4.5 long	3 to 6.3	3 to 6.3	8 to 18	
Preheat	Temperature (T_1 to T_2 , °C)	150 to 180			
	Time (t_1) (max., s)	1210	100		
Duration	Temperature (T_3 , °C)	230	217	230	217
	Time (t_2) (max., s)	30	90	60	60
Peak	Temperature (T_4 , °C)	250	260		250
	Time (t_3 , s)	5			
Reflow cycles	1			2 or less	

X-ON Electronics

Largest Supplier of Electrical and Electronic Components

Click to view similar products for [Aluminium Electrolytic Capacitors - SMD category](#):

Click to view products by [Vishay manufacturer](#):

Other Similar products are found below :

[EEV-FK1E332W](#) [22927](#) [MAL214099813E3](#) [HUB1800-S](#) [HUB470-P](#) [34610](#) [RYK-50V101MG5TT-FL](#) [107AXZ016MQ5](#)
[EMK1EM471GB0D00R](#) [RVT2A4R7M0605](#) [MAL214097402E3](#) [MAL224699909E3](#) [MAL224699813E3](#) [MAL215099017E3](#)
[MAL215099117E3](#) [MAL215099818E3](#) [AEH1010471M010R](#) [AEA0810101M035R](#) [AEA1010681M016R](#) [AEA1010471M025R](#)
[AEA0810331M010R](#) [AEA1616102M050R](#) [AEH1010101M050R](#) [AEH0810470M050R](#) [AEA0810220M100R](#) [AEA0810151M035R](#)
[AEA0810331M016R](#) [AEA0810470M063R](#) [AEA1213471M035R](#) [AEH0608220M050R](#) [AEH0608330M050R](#) [AEH0608470M025R](#)
[AEH0608470M035R](#) [AEH0810101M025R](#) [AEH1012101M063R](#) [GSC00AB2201AARL](#) [GSC00AB2R21HARL](#) [GSC00AB2R21JARL](#)
[GSC00AB3R31HARL](#) [GSC00AC2201EARL](#) [GSC00AC3301AARL](#) [GSC00AC3301CARL](#) [GSC00AC3R31JARL](#) [GSC00AC4R71HARL](#)
[GSC00AD2201HARL](#) [GSC00AD2201VARL](#) [GSC00AD3301VARL](#) [GSC00AD4701CARL](#) [GSC00AD4R71JARL](#) [GSC00AE1001JARL](#)