

Aluminum Electrolytic Capacitors

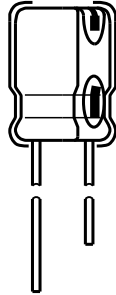

FEATURES

- Polarized aluminum electrolytic capacitors, non-solid electrolyte
- Radial leads, cylindrical aluminum case
- High CV per unit volume
- Ø 10 mm to Ø 18 mm, 105 °C, up to 10 000 h endurance
- Material categorization: For definitions of compliance please see www.vishay.com/doc?99912

RoHS
COMPLIANT

APPLICATIONS

- Decoupling, smoothing, filtering, buffering in SMPS
- Power supplies in industrial equipment, UPS
- Specially suitable for lighting ballasts

QUICK REFERENCE DATA			
DESCRIPTION	UNIT	VALUE	
Nominal case sizes (Ø D x L)	mm	10 x 16 to 18 x 40	
Rated capacitance range	µF	6.8 to 330	
Capacitance tolerance	%	± 20 (at 120 Hz, 20 °C)	
Rated voltage range	V _{DC}	160 to 400	450
Category temperature range	°C	- 40 to + 105	- 25 to + 105
Endurance	h	8000 to 10 000	
Shelf life	h	1000	

ORDERING INFORMATION						
Part number example: HRC00FE1021VTFL						
HRC	00	KG	101	2V	00	L
SERIES NAME	DESIGN/FORMING	DIMENSIONS	CAPACITANCE	VOLTAGE	PACKING	INTERNAL CODE
		See "Dimensions" table	See "Selection Chart"	See "Selection Chart"	00 = Bulk TF = Ammopack, formed lead ⁽¹⁾ TN = Ammopack, straight lead ⁽¹⁾	

Note
⁽¹⁾ See "Taping Specifications"

**ADDITIONAL ELECTRICAL DATA**

LEAKAGE CURRENT (Test conditions: U_R , 20 °C)			
RATED VOLTAGE	TIME	CV	VALUE
160 V to 450 V	After 5 min	≤ 1000	$I = 0.03 CV + 15$ (μA)
		> 1000	$I = 0.02 CV + 25$ (μA)

Notes

- Where, C = Rated capacitance in μF
- V = Rated DC working voltage in V

DISSIPATION FACTOR ($\tan \delta$ at 120 Hz, 20 °C)						
RATED VOLTAGE	160	200	250	350	400	450
$\tan \delta$ (max.)	0.20	0.20	0.20	0.24	0.24	0.24

LOW TEMPERATURE BEHAVIOR (at 120 Hz)						
IMPEDANCE RATIO	RATED VOLTAGE					
	160	200	250	350	400	450
$\frac{Z_{(-25\text{ °C})}}{Z_{(+20\text{ °C})}}$	3	3	3	5	5	6
$\frac{Z_{(-40\text{ °C})}}{Z_{(+20\text{ °C})}}$	6	6	6	6	6	-

Note

- Impedance ratio shall not exceed the values given in the table.

MULTIPLIER OF RIPPLE CURRENT AS A FUNCTION OF FREQUENCY		
FREQUENCY (Hz)	CAPACITANCE (μF)	
	6.8 TO 82	100 AND UP
120	1.00	1.00
1000	1.75	1.67
10 000	2.25	2.05
100 000 and up	2.50	2.25

TEST PROCEDURES AND REQUIREMENTS				
TEST	TEST TIME	CAPACITANCE CHANGE	DISSIPATION FACTOR	LEAKAGE CURRENT
Endurance ⁽¹⁾	8000 h (for $\varnothing D = 10$ mm)	Within ± 20 % of initial value	Less than 200 % of specified value	Within specified value
	10 000 h (for $\varnothing D \geq 12.5$ mm)			
Shelf life ⁽²⁾	1000 h	Within ± 20 % of initial value	Less than 200 % of specified value	Less than 500 % of specified value

Notes

- (1) The specifications shall be satisfied when the capacitors are restored to 20 °C after the rated voltage applied with rated ripple current for 8000 h/10 000 h at 105 °C.
- (2) The above specifications shall be satisfied when the capacitors are restored to 20 °C after exposing them for 1000 h at 105 °C without voltage applied. The rated voltage shall be applied to the capacitors before the measurements (refer to JIS C 5101-4 4.1).

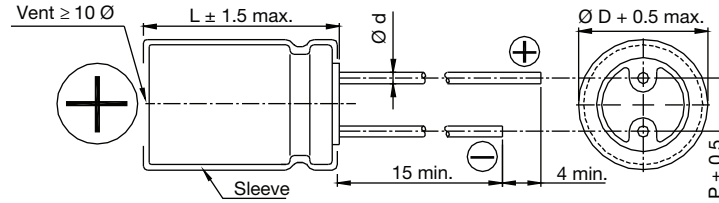
DIMENSIONS in millimeters

CASE SIZE CODE		$\text{Ø D} + 0.5$	$L \pm 1.5$	Ø d	$P \pm 0.5$
DC	10 x 12.5	10	12.5	0.6	5.0
DD	10 x 16	10	16	0.6	5.0
DE	10 x 20	10	20	0.6	5.0
FE	12.5 x 20	12.5	20	0.6	5.0
FG	12.5 x 25	12.5	25	0.6	5.0
JE	16 x 20	16	20	0.8	7.5
JG	16 x 25	16	25	0.8	7.5
KE	18 x 20	18	20	0.8	7.5
KG	18 x 25	18	25	0.8	7.5
KS	18 x 31.5	18	31.5	0.8	7.5
KL	18 x 35.5	18	35.5	0.8	7.5
KK	18 x 40	18	40	0.8	7.5

Note

- Please see "Taping Specifications" for details on taped products



SELECTION CHART, DIMENSIONS, AND PERMISSIBLE RIPPLE CURRENT (mA/RMS at 105 °C)										
V_{DC}		160 V (2C)			200 V (2D)			250 V (2E)		
CAP.	CODE	Ø D x L	RIPPLE CURRENT		Ø D x L	RIPPLE CURRENT		Ø D x L	RIPPLE CURRENT	
			120 Hz	100 kHz		120 Hz	100 kHz		120 Hz	100 kHz
6.8	6R8	-	-	-	-	-	-	-	-	-
10	100	10 x 12.5	100	250	10 x 16	125	313	10 x 20	140	350
22	220	10 x 16 10 x 20	170 200	425 500	10 x 20	200	500	10 x 20	200	500
33	330	10 x 20	250	625	10 x 20	260	650	12.5 x 20	320	800
47	470	10 x 20	300	750	12.5 x 20	390	975	12.5 x 20	390	975
68	680	12.5 x 20	470	1175	12.5 x 20	470	1175	16 x 20	520	1300
82	820	12.5 x 20	510	1275	16 x 20	550	1375	16 x 20	550	1375
100	101	12.5 x 25 16 x 20	620 630	1395 1418	16 x 20	630	1418	16 x 25	680	1530
120	121	-	-	-	-	-	-	-	-	-
150	151	16 x 25	770	1733	16 x 25	840	1890	18 x 25	860	1935
220	221	16 x 31.5	1020	2295	18 x 25	1050	2363	18 x 31.5	1130	2543
330	331	18 x 35.5	1390	3128	18 x 35.5	1430	3218	-	-	-

SELECTION CHART, DIMENSIONS, AND PERMISSIBLE RIPPLE CURRENT (mA/RMS at 105 °C)										
V_{DC}		350 V (2V)			400 V (2G)			450 V (2W)		
CAP.	CODE	Ø D x L	RIPPLE CURRENT		Ø D x L	RIPPLE CURRENT		Ø D x L	RIPPLE CURRENT	
			120 Hz	100 kHz		120 Hz	100 kHz		120 Hz	100 kHz
6.8	6R8	10 x 16	110	275	10 x 16	110	275	10 x 20	110	275
10	100	10 x 20	140	350	10 x 20	140	350	12.5 x 20	180	450
22	220	12.5 x 20	260	650	12.5 x 20	260	650	16 x 20	290	725
33	330	16 x 20	360	900	16 x 20	360	900	16 x 25 18 x 20	390 380	975 950
47	470	16 x 20	430	1075	16 x 25 18 x 20	470 450	1175 1125	18 x 25	480	1200
68	680	16 x 25 18 x 20	560 550	1400 1375	18 x 25	585	1463	18 x 31.5	630	1575
82	820	18 x 25	610	1525	18 x 25	610	1525	18 x 35.5	715	1788
100	101	18 x 25	700	1575	18 x 31.5	765	1721	18 x 40	800	1800
120	121	18 x 31.5	830	1868	18 x 35.5	865	1946	-	-	-
150	151	18 x 35.5	960	2160	18 x 40	985	2216	-	-	-
220	221	-	-	-	-	-	-	-	-	-
330	331	-	-	-	-	-	-	-	-	-

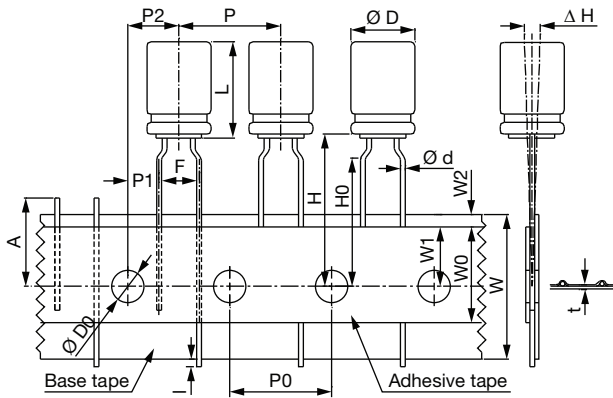

Fig. 1

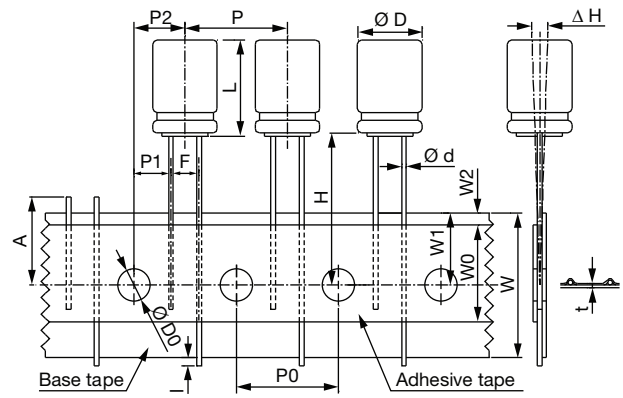

Fig. 3

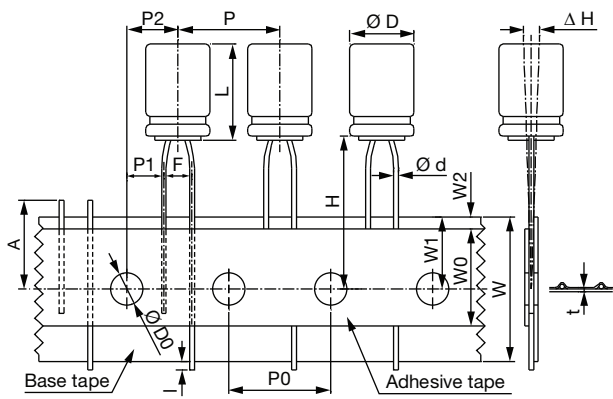

Fig. 2

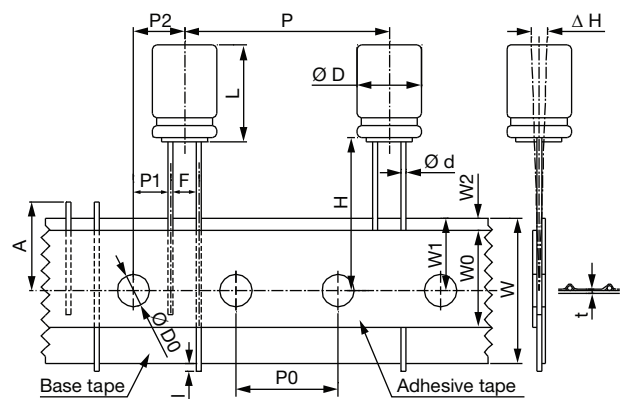

Fig. 4

TAPE SPECIFICATIONS in millimeters																										
PACKING	TF												TN													
	5				7 to 9				≥ 11				5	≥ 7	7 to 9	11.5 to 20	9 to 25									
Ø D	3	4*	5	6.3	8	5	6.3	8*	5	6.3	8	3	4*	5	6.3	8	5	6.3	8	8	TOL.	10	12.5	TOL.		
SYMBOL																										
Ø d	0.4	0.45		0.5		0.5		0.6		0.4	0.45		0.5		0.5		0.6		± 0.05		0.6		± 0.05			
F	5.0			5.0			5.0			2.5			2.5		3.5		3.5		+ 0.8/- 0.2		5.0		+ 0.8/- 0.2			
H	17.5			17.5			18.5			20.0		17.5			17.5		17.5		18.5		± 0.75		18.5		± 0.75	
H0	16.0			16.0			16.0			-			-		-		-		± 0.5		-		± 0.5			
P	12.7			12.7			12.7			12.7			12.7		12.7		12.7		± 1.0		12.7		25.4		± 1.0	
P0	12.7			12.7			12.7			12.7			12.7		12.7		12.7		± 0.2		12.7		± 0.2			
P1	3.85		3.85		3.85		3.85		5.1		5.1		4.6		4.6		4.6		± 0.5		3.85		± 0.7			
P2	6.35		6.35		6.35		6.35		6.35		6.35		6.35		6.35		6.35		± 1.0		6.35		± 1.3			
W	18.0			18.0			18.0			18.0			18.0		18.0		18.0		± 0.5		18.0		± 0.5			
W0	6.0		10.0		10.0		12		6.0		10.0		10.0		12.0		Min.		12.0		12.0		Min.			
W1	9.0		9.0		9.0		9.0		9.0		9.0		9.0		9.0		± 0.5		9.0		9.0		± 0.5			
W2	1.5		1.5		1.5		1.5		1.5		1.5		1.5		1.5		1.5		Max.		1.5		Max.			
A	11.0		11.0		11.0		11.0		11.0		11.0		11.0		11.0		11.0		Max.		11.0		Max.			
Ø D0	4.0		4.0		4.0		4.0		4.0		4.0		4.0		4.0		4.0		± 0.2		4.0		± 0.2			
Δ H	0		0		0		0		0		0		0		0		0		± 1.0		0		± 1.0			
l	1.0		1.0		1.0		1.0		1.0		1.0		1.0		1.0		1.0		Max.		1.0		Max.			
t	0.7		0.7		0.7		0.7		0.7		0.7		0.7		0.7		0.7		± 0.2		0.7		± 0.2			
Fig. No.	1					2		3		2		3		3		3		3		3		3		4		

Notes

- For Ø D = 10, H = 20.0 ± 0.5 is available, in this case, the dimensions of H is not specified
- 4 Ø in mark of "*" is 4 Ø x 7 L the same spec. "TN" packing: 5 to 6.3 Ø x 11 L in H is 18.5
- For 3 to 8 Ø x 5 L, W0 = 10.0 is available

PACKAGING

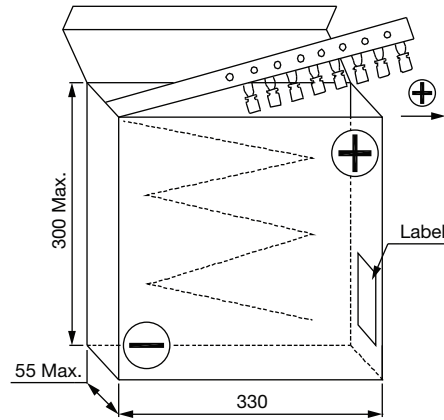

Fig. 5 - Ammopack box

PACKAGING QUANTITY (pcs per box)							
Ø D (mm)	3	4	5	6.3	8	10	12.5
TF, TN	3000	2000	2000	2000	1000	500	300

Note

- The component shall be oriented on the tape as such that the positive lead is leading or the negative lead is leading with customer's request

X-ON Electronics

Largest Supplier of Electrical and Electronic Components

Click to view similar products for [Aluminium Electrolytic Capacitors - Radial Leaded](#) category:

Click to view products by [Vishay](#) manufacturer:

Other Similar products are found below :

[LXY50VB4.7M-5X11](#) [RFO-100V471MJ7P#](#) [ECE-A1EGE220](#) [1814181](#) [NCD681K10KVY5PF](#) [NEV1000M25EF-BULK](#) [NEV100M35DC](#)
[NEV100M63DE](#) [NEV220M25DD-BULK](#) [NEV.33M100AA](#) [NEV4700M50HB](#) [NEV.47M100AA](#) [NEVH1.0M250AB](#) [NEVH3.3M250BB](#)
[NEVH3.3M450CC](#) [KME50VB100M-8X11.5](#) [SG220M1CSA-0407](#) [ES5107M016AE1DA](#) [ESMG160ETD102MJ16S](#) [ESX472M16B](#)
[476CKH100MSA](#) [477RZS050M](#) [UVX1V101KPA1FA](#) [UVX1V222MHA1CA](#) [KME25VB100M-6.3X11](#) [VTL100S10](#) [VTL470S10](#)
[511D336M250EK5D](#) [052687X](#) [ECE-A1CF471](#) [EKXG451ELL820MM30S](#) [686CKR050M](#) [NRE-S560M16V6.3X7TBSTF](#)
[ERZA630VHN182UP54N](#) [UPL1A331MPH](#) [NEV1000M6.3DE](#) [NEV100M16CB](#) [NEV100M50DD-BULK](#) [NEV2200M16FF](#) [NEV220M50EE](#)
[NEV2.2M50AA](#) [NEV330M63EF](#) [NEV4700M35HI](#) [NEV4.7M100BA](#) [NEV47M16BA](#) [NEV47M50CB-BULK](#) [NEVH1.0M350AB](#)
[NEVH2.2M160AB](#) [NEVH3.3M350BC](#) [TER330M50GM](#)