

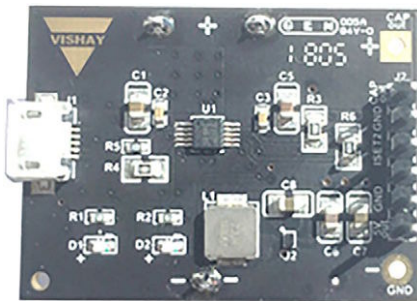

Power Management Solution With 196 HVC ENYCAP™ for Mini Charger and Fixed Voltage Supply Board

By Gerald Tatschl

MAL219699003E3 196 HVC ENYCAP™ - MINI CHARGER AND BACKUP BOARD



DESCRIPTION

The MAL219699003E3 mini charger and backup demonstration circuit is a fully transparent charger unit that uses a BQ24095 charging IC and TPS610997 boost converter IC from Texas Instruments to boost the capacitor voltage up to a 5 V constant output voltage.

This mini charger is equipped with a 90 F / 4.2 V 196 HVC ENYCAP™ hybrid energy storage capacitor, which is charged through the power input. This power input is compatible with a USB port. The charged energy is buffered in the 196 HVC capacitor and can be used for backup power.

An independent fixed output voltage of 5 V is created from the backup power of the hybrid capacitor by the TPS610997 synchronous boost converter IC, which provides a constant output voltage with very high efficiency.

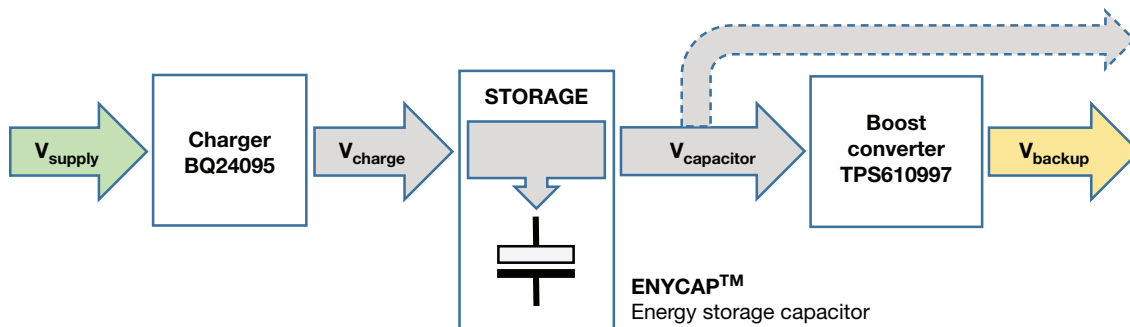

Fig. 1 - Typical block diagram for a backup application and fixed output supply. The storage element is charged through a USB socket V_{supply} . The constant output voltage V_{backup} is provided independently from V_{supply} by the boost converter. Alternatively, the path $V_{capacitor}$ can be used

ENERGY STORAGE CAPACITOR

A 90 F / 4.2 V 196 HVC ENYCAP hybrid energy storage capacitor is used as an energy buffer in the MAL219690111E3 mini charger, and will provide a fixed output voltage supply with its backup function.

The backup time provided by the capacitor depends mainly on the backup current and is indicated in Fig. 2. In the proposed configuration, minutes to hours are achievable.

Power Management Solution With 196 HVC ENYCAP™ for Mini Charger and Fixed Voltage Supply Board

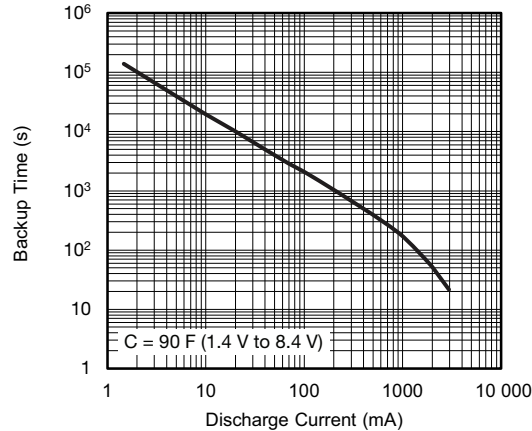

Fig. 2 - Typical backup time as a function of discharge current

CHARGING IC

Texas Instruments' BQ24095 is a low cost linear type (LDO) charger with a CC / CV (constant current / constant voltage) mode charging profile of up to 1.25 A. The charging current is adjustable to USB requirements. The charging voltage of the CV mode will be fixed at 4.35 V. The detailing pin assignment is shown in Table 1.

The BQ24095 is a highly integrated linear charger device, targeted at space-limited portable applications. The IC operates from either a USB port or AC adapter. The high input voltage range with input overvoltage protection supports low cost unregulated adapters.

The BQ24095 has a single power output that charges a backup system. A load can be placed in parallel with the backup capacitor as long as the average system load does not keep the capacitor from charging fully during the 10-hour safety time.

TABLE 1 - PIN ASSIGNMENT BQ24095

PIN #	PIN NAME	FUNCTION
1	IN	Source input Directly connected with a micro USB connector
2	ISET	Maximum current setting (CC mode) R5 is assembled with 2 kΩ to GND for a 300 mA limit
3	VSS	Connected to GND
4	PRETERM	Maximum current setting (CV mode) 1 kΩ to GND for a 50 mA limit on CV mode charging
5	PG	LED indicator for input voltage ON: input voltage is normal (4.45 V ~ 6.45 V) OFF: UVLO or input voltage is abnormal
6	NC	Leave it floating
7	ISET2	Total current limit Connected to GND, means it follows ISET
8	CHG	LED indicator for charging state ON: charging OFF: not charging
9	TS	Temp sensor Function disabled, 10 kΩ to GND
10	OUT	Output of linear charger, directly connected to 196 HVC 4.35 V fixed voltage feedback and regulated



Power Management Solution With 196 HVC ENYCAP™ for Mini Charger and Fixed Voltage Supply Board

BOOST IC

Texas Instruments' TPS610997 is a synchronous boost converter with ultra low quiescent current. This device is designed for products powered by a power backup solution, for which high efficiency under light load conditions (up to 300 mA at 5 V) and long backup life operation are critical to achieve.

The TPS610997 supports a true shutdown function when it is disabled, which disconnects the load from the input supply to reduce the current consumption.

TABLE 2 - PIN ASSIGNMENT TPS610997		
PIN #	PIN NAME	FUNCTION
A1	VIN	IC power supply input
		Directly connected to 196 HVC, plus terminal
B1	SW	Switch pin of the converter. It is connected to the inductor
C1	EN	Enable logic input. Logic high voltage enables the device; logic low voltage disables the device. Do not leave it floating
A2	GND	Ground
B2	VOUT	Boost converter output; it is fixed at 5 V
C2	FB	Voltage feedback of adjustable output voltage. Connect to the center tap of a resistor divider to program the output voltage. Connect to GND pin for fixed output voltage versions

GETTING STARTED

This section provides information on how to start the mini charger.

CHARGING

Plug the micro USB terminal into the connector on the board, or supply power to the mini charger through another terminal, such as a power bank, a 5 V output, AC/DC adapter, or even just from the USB port of a PC.

A voltage between 4.45 V and 6.45 V is allowed for this input.

DISCHARGING DIRECTLY FROM THE 196 HVC ENYCAP

Connect the load directly to the ENYCAP storage capacitor's pin J2, pin 1 (+), and pin 5 (GND) (take care to stay within the current and power limits of the charger IC).

If power input is removed, the load will be powered only by the 196 HVC backup capacitor.

In this mode, the voltage of the 196 HVC capacitor will decrease depending on the power consumption of the load.

Typical example: a micro controller unit (MCU) may operate in a working voltage range between 2.7 V and 5 V.

The voltage of the storage capacitor is permitted to drop to $n \times 0.8 \text{ V}$; n is the number of cells. For example, a 4.2 V 196 HVC capacitor consists of three cells, so that $n \times 0.8 \text{ V} = 2.4 \text{ V}$. In this case, the stored energy of the capacitor cannot be fully used.

DISCHARGING VIA A 5 V FIXED OUTPUT BOOST CONVERTER

For certain load types, such as a fan or LED, fixed voltage output is necessary. In these cases, connect the load to the output of the boost converter J2, pin 6 (V_{OUT}) and pin 5 (GND), and remove the power source as well.

In this mode, with the boost converter, all stored energy can be used. The load can be powered until the storage capacitor is completely discharged.

TECHNICAL NOTE

Power Management Solution With 196 HVC ENYCAP™ for Mini Charger and Fixed Voltage Supply Board

SCHEMATIC DIAGRAM

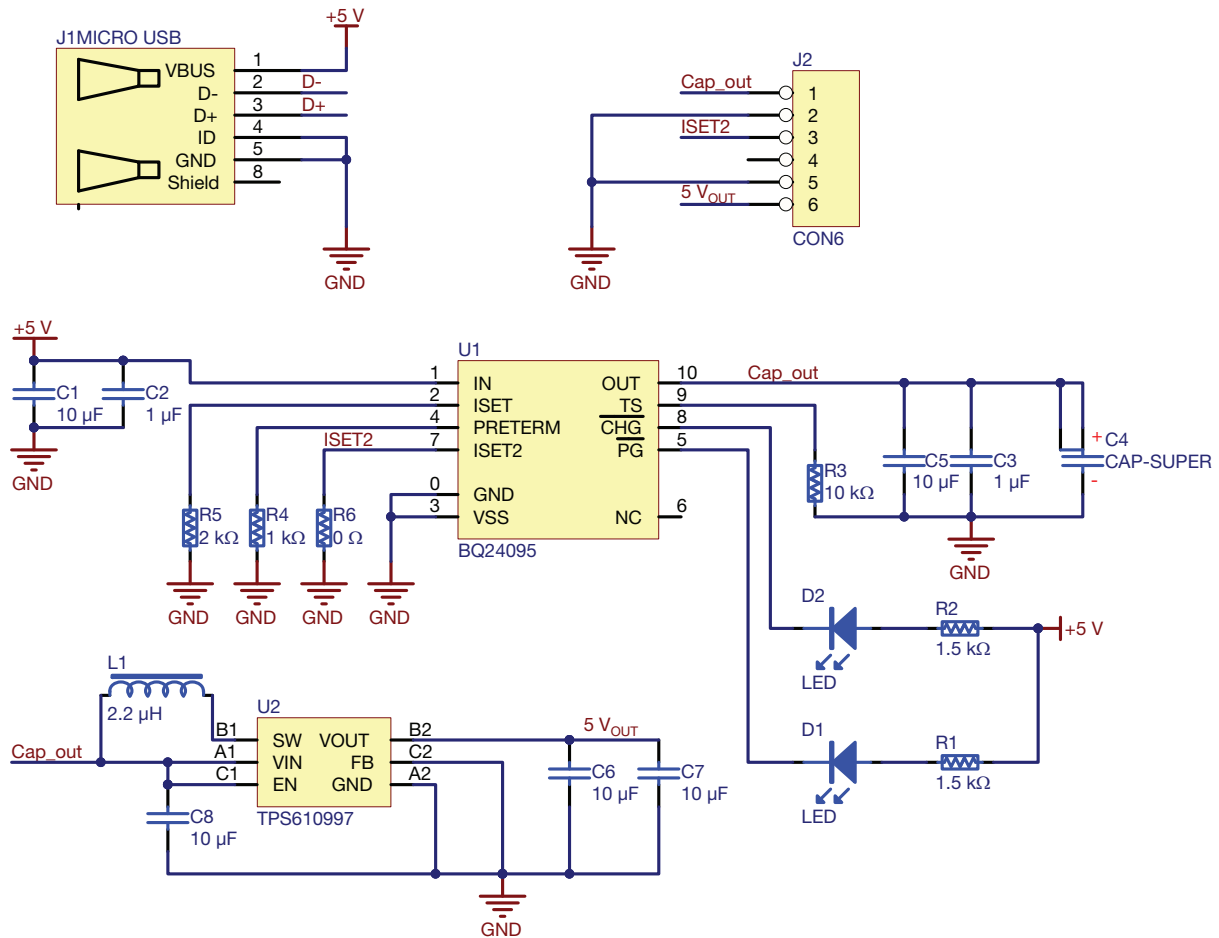

Fig. 3 - Schematic of mini charger

Power Management Solution With 196 HVC ENYCAP™ for Mini Charger and Fixed Voltage Supply Board

LAYOUT AND CONNECTION

Fig. 4 - PCB layout, mini charger

BILL OF MATERIAL			
NAME	VALUE	SPECIFICATION	MANUFACTURER
C1, C5, C6, C7, C8	10 μ F / 16 V	MLCC	
C2, C3	1 μ F / 35 V	MLCC	
C4	90 F / 4.2 V, MAL219690111E3	196 HVC	Vishay
D1, D2	LED, SMD 0603		
J1	Micro USB connector		
L1	IHLP2020ABER2R2M01, 2.2 μ H	IHLP	Vishay
R1, R2	1.5 k Ω , 0603		
R3	10 k Ω , 0603		
R4	1 k Ω , 0603		
R5	2 k Ω , 0603		
R6	NC		
U1	BQ24095		
U2	TPS610997		

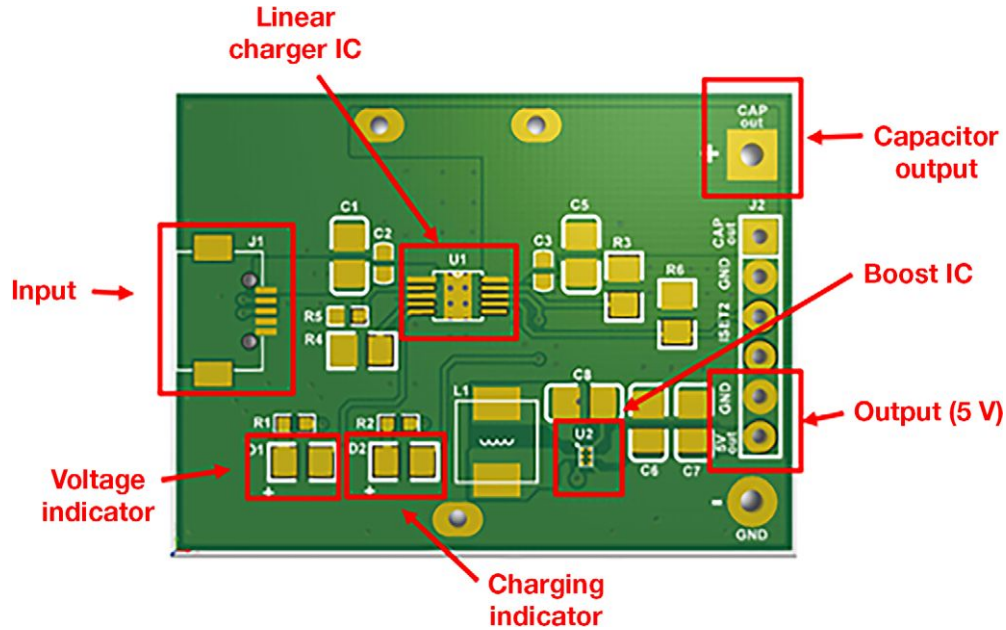

Power Management Solution With 196 HVC ENYCAP™ for Mini Charger and Fixed Voltage Supply Board

INCLUDED MATERIALS

ENYCAP mini charger kit for 90 F / 4.2 V

1. Board: 30 mm x 40 mm
2. ENYCAP 196 HVC 90 F / 4.2 V, MAL219690111E3
3. USB - micro USB cable
4. This document

Link to the product specification: www.vishay.com/doc?28409

Thank you for using and buying the ENYCAP mini charger board. If you need further information, please contact:

Vishay BCcomponents - Aluminum Capacitors
Mr. Gerald Tatschl, Dipl. Ing.
Sr. Manager Product Marketing Aluminum Capacitors
Ebentaler Strasse 140
A - 9020 Klagenfurt, Austria, Europe

Phone: +43 463 3834 314
Mobile: +43 664 395 00 66
E-mail: hybridstorage@vishay.com

X-ON Electronics

Largest Supplier of Electrical and Electronic Components

Click to view similar products for [Power Management IC Development Tools](#) category:

Click to view products by [Vishay](#) manufacturer:

Other Similar products are found below :

[EVAL-ADM1168LQEBZ](#) [EVB-EP5348UI](#) [MIC23451-AAAYFL EV](#) [MIC5281YMME EV](#) [DA9063-EVAL](#) [ADP122-3.3-EVALZ](#) [ADP130-0.8-EVALZ](#) [ADP130-1.2-EVALZ](#) [ADP130-1.5-EVALZ](#) [ADP130-1.8-EVALZ](#) [ADP1714-3.3-EVALZ](#) [ADP1716-2.5-EVALZ](#) [ADP1740-1.5-EVALZ](#) [ADP1752-1.5-EVALZ](#) [ADP1828LC-EVALZ](#) [ADP1870-0.3-EVALZ](#) [ADP1871-0.6-EVALZ](#) [ADP1873-0.6-EVALZ](#) [ADP1874-0.3-EVALZ](#) [ADP1882-1.0-EVALZ](#) [ADP199CB-EVALZ](#) [ADP2102-1.25-EVALZ](#) [ADP2102-1.875EVALZ](#) [ADP2102-1.8-EVALZ](#) [ADP2102-2-EVALZ](#) [ADP2102-3-EVALZ](#) [ADP2102-4-EVALZ](#) [ADP2106-1.8-EVALZ](#) [ADP2147CB-110EVALZ](#) [AS3606-DB](#) [BQ24010EVM](#) [BQ24075TEVM](#) [BQ24155EVM](#) [BQ24157EVM-697](#) [BQ24160EVM-742](#) [BQ24296MEVM-655](#) [BQ25010EVM](#) [BQ3055EVM](#) [NCV891330PD50GEVB](#) [ISLUSBI2CKIT1Z](#) [LM2744EVAL](#) [LM2854EVAL](#) [LM3658SD-AEV/NOPB](#) [LM3658SDEV/NOPB](#) [LM3691TL-1.8EV/NOPB](#) [LM4510SDEV/NOPB](#) [LM5033SD-EVAL](#) [LP38512TS-1.8EV](#) [EVAL-ADM1186-1MBZ](#) [EVAL-ADM1186-2MBZ](#)