

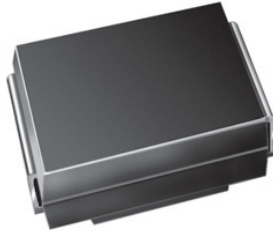

Surface Mount Power Voltage-Regulating Diodes



DO-214AA (SMBJ)

FEATURES

- Low profile package
- Ideal for automated placement
- Glass passivated chip junction
- Low Zener impedance
- Low regulation factor
- Meets MSL level 1, per J-STD-020, if maximum peak of 260 °C
- Material categorization: For definitions of compliance please see www.vishay.com/doc?99912



RoHS
COMPLIANT
HALOGEN
FREE

TYPICAL APPLICATIONS

For general purpose regulation and protection applications.

PRIMARY CHARACTERISTICS	
V _Z	9.1 V to 68 V
P _{tot}	1500 mW
I _R (V _Z ≥ 12 V)	5.0 μA
T _J max.	150 °C
V _Z specification	Pulse current
Int. construction	Single

MECHANICAL DATA

Case: DO-214AA (SMBJ)

Molding compound meets UL 94 V-0 flammability rating
Base P/N-M3 - halogen-free, RoHS compliant, and commercial grade

Terminals: Matte tin plated leads, solderable per J-STD-002 and JESD22-B102

M3 suffix meets JESD 201 class 1A whisker test

Polarity: Color band denotes cathode end

MAXIMUM RATINGS (T _A = 25 °C, unless otherwise noted)			
PARAMETER	SYMBOL	VALUE	UNIT
Operating junction and storage temperature range	T _J , T _{STG}	- 55 to + 150	°C



ELECTRICAL CHARACTERISTICS (T_A = 25 °C unless otherwise noted)

PART NUMBER	DEVICE MARKING CODE	ZENER VOLTAGE RANGE			TEST CURRENT		MAXIMUM ZENER IMPEDANCE		MAXIMUM REVERSE CURRENT		MAXIMUM ZENER CURRENT ⁽¹⁾
		V _Z AT I _{ZT}			I _{ZT}	I _{ZK}	Z _{ZT} AT I _{ZT}	Z _{ZK} AT I _{ZK}	I _R AT V _R		I _{ZM}
		V			mA		Ω		μA	V	mA
		MIN.	NOM.	MAX.			MAX.	MAX.	MAX.		MAX.
SMZJ3788B	VL	8.65	9.1	9.56	41.2	0.50	4.0	1000	50	7.0	140
SMZJ3789B	WB	9.50	10	10.5	37.5	0.25	5.0	1000	50	7.6	125
SMZJ3790B	WD	10.5	11	11.6	34.1	0.25	6.0	650	10	8.4	115
SMZJ3791B	WF	11.4	12	12.6	31.2	0.25	7.0	550	5.0	9.1	105
SMZJ3792B	WH	12.4	13	13.7	28.8	0.25	7.5	550	5.0	9.9	98
SMZJ3793B	WJ	14.3	15	15.8	25.0	0.25	9.0	600	5.0	11.4	85
SMZJ3794B	WL	15.2	16	16.8	23.4	0.25	10.0	600	5.0	12.2	80
SMZJ3795B	XB	17.1	18	18.9	20.8	0.25	12.0	650	5.0	13.7	70
SMZJ3796B	XD	19.0	20	21.0	18.7	0.25	14.0	650	5.0	15.2	62
SMZJ3797B	XF	20.9	22	23.1	17.0	0.25	17.5	650	5.0	16.7	56
SMZJ3798B	XH	22.8	24	25.2	15.6	0.25	19.0	700	5.0	18.2	51
SMZJ3799B	XJ	25.7	27	28.4	13.9	0.25	23.0	700	5.0	20.6	46
SMZJ3800B	XL	28.5	30	31.5	12.5	0.25	26.0	750	5.0	22.8	41
SMZJ3801B	YB	31.4	33	34.7	11.4	0.25	33.0	800	5.0	25.1	38
SMZJ3802B	YD	34.2	36	37.8	10.4	0.25	38.0	850	5.0	27.4	35
SMZJ3803B	YF	37.1	39	41.0	9.6	0.25	45.0	900	5.0	29.7	31
SMZJ3804B	YH	40.9	43	45.2	8.7	0.25	53.0	950	5.0	32.7	28
SMZJ3805B	YJ	44.7	47	49.4	8.0	0.25	67.0	1000	5.0	35.8	26
SMZJ3806B	YL	48.5	51	53.6	7.3	0.25	70.0	1100	5.0	38.8	24
SMZJ3807B	ZB	53.2	56	58.8	6.7	0.25	86.0	1300	5.0	42.6	22
SMZJ3808B	ZD	58.9	62	65.1	6.0	0.25	100.0	1500	5.0	47.1	20
SMZJ3809B	ZF	64.6	68	71.4	5.5	0.25	120.0	1700	5.0	51.7	18

Note

⁽¹⁾ Maximum steady state power dissipation is 1500 mW at T_L = 75 °C (fig. 1)

ORDERING INFORMATION (Example)

PREFERRED P/N	UNIT WEIGHT (g)	PREFERRED PACKAGE CODE	BASE QUANTITY	DELIVERY MODE
SMZJ3788B-M3/52	0.096	52	750	7" diameter plastic tape and reel
SMZJ3788B-M3/5B	0.096	5B	3200	13" diameter plastic tape and reel

RATINGS AND CHARACTERISTICS CURVES

($T_A = 25\text{ }^\circ\text{C}$ unless otherwise noted)

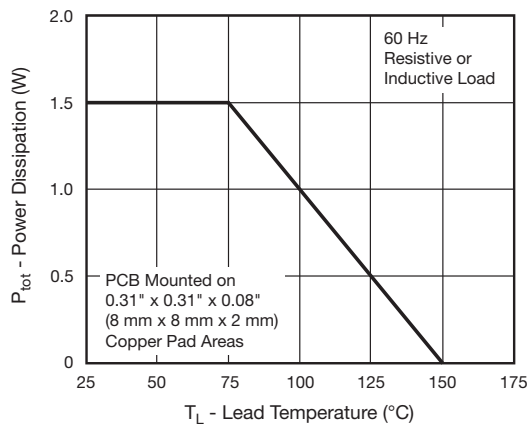

Fig. 1 - Maximum Continuous Power Dissipation

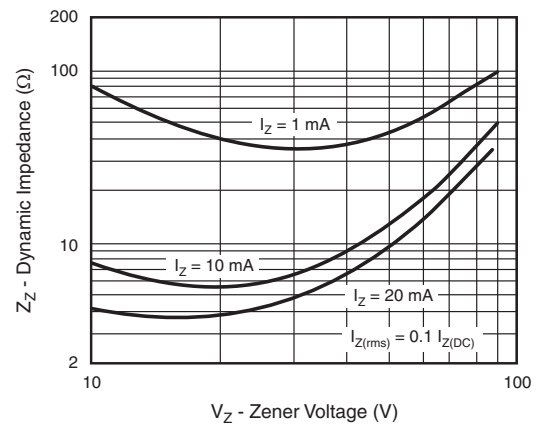

Fig. 3 - Typical Zener Impedance

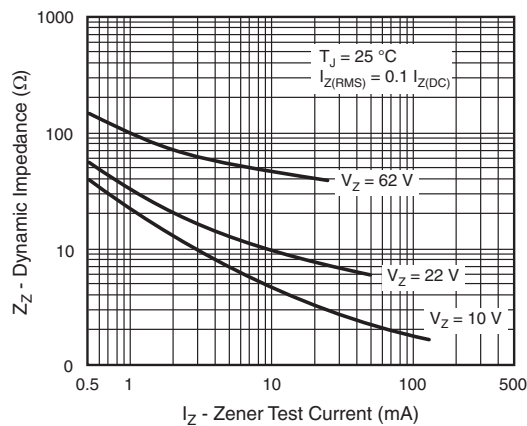

Fig. 2 - Typical Zener Impedance

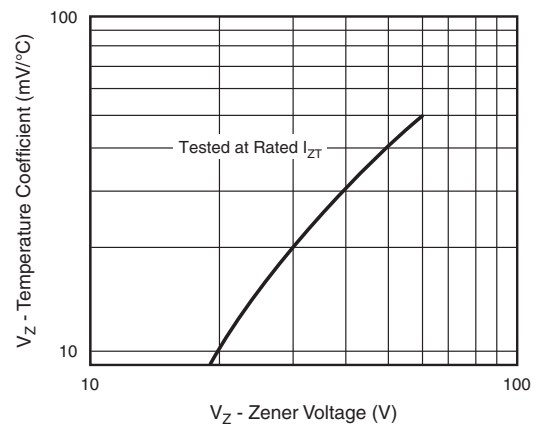
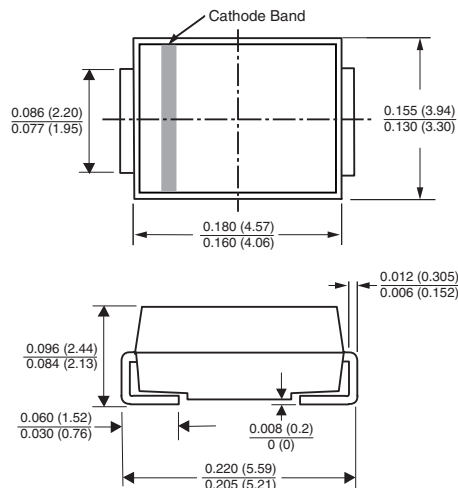

Fig. 4 - Typical Temperature Coefficients

PACKAGE OUTLINE DIMENSIONS in inches (millimeters)

DO-214AA (SMB)



Mounting Pad Layout

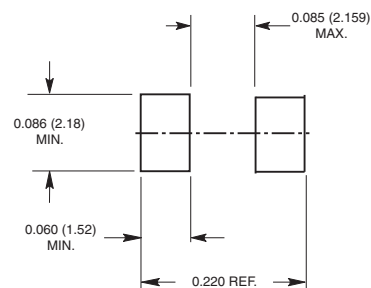



Disclaimer

ALL PRODUCT, PRODUCT SPECIFICATIONS AND DATA ARE SUBJECT TO CHANGE WITHOUT NOTICE TO IMPROVE RELIABILITY, FUNCTION OR DESIGN OR OTHERWISE.

Vishay Intertechnology, Inc., its affiliates, agents, and employees, and all persons acting on its or their behalf (collectively, "Vishay"), disclaim any and all liability for any errors, inaccuracies or incompleteness contained in any datasheet or in any other disclosure relating to any product.

Vishay makes no warranty, representation or guarantee regarding the suitability of the products for any particular purpose or the continuing production of any product. To the maximum extent permitted by applicable law, Vishay disclaims (i) any and all liability arising out of the application or use of any product, (ii) any and all liability, including without limitation special, consequential or incidental damages, and (iii) any and all implied warranties, including warranties of fitness for particular purpose, non-infringement and merchantability.

Statements regarding the suitability of products for certain types of applications are based on Vishay's knowledge of typical requirements that are often placed on Vishay products in generic applications. Such statements are not binding statements about the suitability of products for a particular application. It is the customer's responsibility to validate that a particular product with the properties described in the product specification is suitable for use in a particular application. Parameters provided in datasheets and/or specifications may vary in different applications and performance may vary over time. All operating parameters, including typical parameters, must be validated for each customer application by the customer's technical experts. Product specifications do not expand or otherwise modify Vishay's terms and conditions of purchase, including but not limited to the warranty expressed therein.

Except as expressly indicated in writing, Vishay products are not designed for use in medical, life-saving, or life-sustaining applications or for any other application in which the failure of the Vishay product could result in personal injury or death. Customers using or selling Vishay products not expressly indicated for use in such applications do so at their own risk. Please contact authorized Vishay personnel to obtain written terms and conditions regarding products designed for such applications.

No license, express or implied, by estoppel or otherwise, to any intellectual property rights is granted by this document or by any conduct of Vishay. Product names and markings noted herein may be trademarks of their respective owners.

Material Category Policy

Vishay Intertechnology, Inc. hereby certifies that all its products that are identified as RoHS-Compliant fulfill the definitions and restrictions defined under Directive 2011/65/EU of The European Parliament and of the Council of June 8, 2011 on the restriction of the use of certain hazardous substances in electrical and electronic equipment (EEE) - recast, unless otherwise specified as non-compliant.

Please note that some Vishay documentation may still make reference to RoHS Directive 2002/95/EC. We confirm that all the products identified as being compliant to Directive 2002/95/EC conform to Directive 2011/65/EU.

Vishay Intertechnology, Inc. hereby certifies that all its products that are identified as Halogen-Free follow Halogen-Free requirements as per JEDEC JS709A standards. Please note that some Vishay documentation may still make reference to the IEC 61249-2-21 definition. We confirm that all the products identified as being compliant to IEC 61249-2-21 conform to JEDEC JS709A standards.

X-ON Electronics

Largest Supplier of Electrical and Electronic Components

Click to view similar products for [Zener Diodes](#) category:

Click to view products by [Vishay](#) manufacturer:

Other Similar products are found below :

[RKZ13B2KG#P1](#) [DL5234B](#) [EDZTE6113B](#) [1N4682](#) [1N4691](#) [1N4693](#) [1N4732A](#) [1N4733A-TR](#) [1N4736A](#) [1N4750A](#) [1N4759ARL](#) [1N5241B](#)
[1N5365B](#) [1N5369B](#) [1N747A](#) [1N959B](#) [1N964B](#) [1N966B](#) [1N968B](#) [1N972B](#) [NTE149A](#) [NTE5116A](#) [NTE5121A](#) [NTE5147A](#) [NTE5152A](#)
[NTE5155A](#) [NTE5164A](#) [JANS1N4974US](#) [1N4692](#) [1N4700](#) [1N4702](#) [1N4704](#) [1N4711](#) [1N4714](#) [1N4737A](#) [1N4745ARL](#) [1N4752A](#)
[1N4752ARL](#) [1N4760ARL](#) [1N5221B](#) [1N5236B](#) [1N5241BTR](#) [1N5242BTR](#) [1N5350B](#) [1N5352B](#) [1N961BRR1](#) [1N964BRL](#) [RKZ5.1BKU#P6](#)
[3SMAJ5950B-TP](#) [3SMBJ5925B-TP](#)