

Thick Film Resistor Networks, Dual-In-Line, Wide Body, Small Outline, Molded DIP, Surface



FEATURES

- Isolated, bussed, and dual terminator schematics available
- 0.110" (2.79 mm) maximum seated height
- Rugged, molded case construction
- 0.050" (1.27 mm) lead spacing
- Reduces total assembly costs
- Compatible with automatic surface mounting equipment
- Uniform performance characteristics
- Meets EIA PDP 100, SOGN-0003 outline dimensions
- Available in tube pack or tape and reel pack
- Material categorization: For definitions of compliance please see www.vishay.com/doc?99912

 Available
 RoHS*
 Available

Note

* This datasheet provides information about parts that are RoHS-compliant and/or parts that are non-RoHS-compliant. For example, parts with lead (Pb) terminations are not RoHS-compliant. Please see the information/tables in this datasheet for details.

STANDARD ELECTRICAL SPECIFICATIONS							
GLOBAL MODEL	SCHEMATIC	POWER RATING ELEMENT W $P_{70^\circ\text{C}}$	POWER RATING PACKAGE W $P_{70^\circ\text{C}}$	TOLERANCE $\pm\%$ (1)	RESISTANCE RANGE Ω	MAXIMUM WORKING VOLTAGE V_{DC} (2)	TEMPERATURE COEFFICIENT $\pm\text{ppm}/^\circ\text{C}$
SOGC16	01	0.1	1.6	1, 2, 5	10 to 1M	50	100
	03	0.19	1.6	1, 2, 5	10 to 1M	50	100
	05	0.1	1.6	1, 2, 5	10 to 1M	50	100
SOGC20	01	0.1	2.0	1, 2, 5	10 to 1M	50	100
	03	0.19	2.0	1, 2, 5	10 to 1M	50	100
	05	0.1	2.0	1, 2, 5	10 to 1M	50	100

Notes

- 100 m Ω maximum on 0 Ω -jumper.
- (1) $\pm 2\%$ standard, $\pm 1\%$ and $\pm 5\%$ available.
- (2) Continuous working voltage shall be $\sqrt{P \times R}$ or maximum working voltage, whichever is less.

GLOBAL PART NUMBER INFORMATION																	
New Global Part Numbering: SOGC200310K0GDC (preferred part numbering format)																	
S	O	G	C	2	0	0	3	1	0	K	0	G	D	C			
GLOBAL MODEL SOGC	PIN COUNT 16 20	SCHEMATIC 01 = Bussed 03 = Isolated 00 = Special	RESISTANCE VALUE R = Ω K = k Ω M = M Ω 10R0 = 10 Ω 680K = 680 k Ω 1M00 = 1.0 M Ω 0000 = 0 Ω Jumper	TOLERANCE CODE F = $\pm 1\%$ G = $\pm 2\%$ J = $\pm 5\%$ S = Special Z = 0 Ω Jumper	PACKAGING EJ = Lead (Pb)-free, tube EA = Lead (Pb)-free, tape and reel DC = Tin/lead, tube RZ = Tin/lead, tape and reel	SPECIAL Blank = Standard (Dash number) (Up to 3 digits) From 1 to 999 as applicable											
Historical Part Number example: SOGC2002103G (will continue to be accepted)																	
SOGC	20	03	103	G	D02												
HISTORIC MODEL	PIN COUNT	SCHEMATIC	RESISTANCE VALUE	TOLERANCE CODE	PACKAGING												
New Global Part Numbering: SOGC1605131AGRZ (preferred part numbering format)																	
S	O	G	C	1	6	0	5	1	3	1	A	G	R	Z			
GLOBAL MODEL SOGC	PIN COUNT 16 20	SCHEMATIC 05 = Dual terminator	RESISTANCE VALUE 3 digit impedance code, followed by alpha modifier (see Impedance Codes table)	TOLERANCE CODE F = $\pm 1\%$ G = $\pm 2\%$ J = $\pm 5\%$	PACKAGING EJ = Lead (Pb)-free, tube EA = Lead (Pb)-free, tape and reel DC = Tin/lead, tube RZ = Tin/lead, tape and reel	SPECIAL Blank = Standard (Dash number) (Up to 3 digits) From 1 to 999 as applicable											
Historical Part Number example: SOGC1605221331G (will continue to be accepted)																	
SOGC	16	05	221	331	G	R61											
GLOBAL MODEL	PIN COUNT	SCHEMATIC	RESISTANCE VALUE 1	RESISTANCE VALUE 2	TOLERANCE CODE	PACKAGING											

Note

- For additional information on packaging, refer to the Surface Mount Network Packaging document (www.vishay.com/doc?31540).

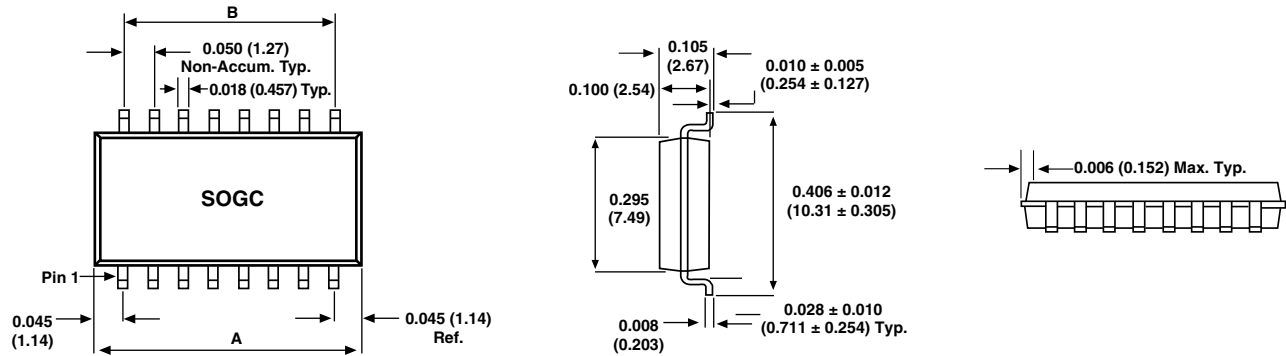
DIMENSIONS in inches (millimeters)

GLOBAL MODEL	A	B
SOGC16	0.440 (11.18)	0.350 (8.89)
SOGC20	0.540 (13.72)	0.450 (11.43)

TECHNICAL SPECIFICATIONS			
PARAMETER	UNIT	SOGC16	SOGC20
Package power rating (max. at +70 °C)	W	1.6	2.0
TCR tracking (-55 °C to +125 °C)	ppm/°C	± 50	
Voltage coefficient of resistance	ppm/V	< 50 typical	
Maximum operating voltage	V _{DC}	50	
Operating temperature range	°C	-55 to +125	
Storage temperature range	°C	-55 to +150	

MECHANICAL SPECIFICATIONS	
Marking	Model number, schematic number, value tolerance, pin 1 indicator, date code
Marking resistance to solvents	Permanency testing per MIL-STD-202, method 215
Maximum solder reflow temperature	+255 °C
Solderability	Per MIL-STD-202, method 208E
Terminals	Copper alloy. Solder dipped terminal
Body	Molded epoxy

IMPEDANCE CODES					
CODE	R ₁ (Ω)	R ₂ (Ω)	CODE	R ₁ (Ω)	R ₂ (Ω)
500B	82	130	141A	270	270
750B	120	200	181A	330	390
800C	130	210	191A	330	470
990A	160	260	221B	330	680
101C	180	240	281B	560	560
111C	180	270	381B	560	1.2K
121B	180	390	501C	620	2.7K
121C	220	270	102A	1.5K	3.3K
131A	220	330	202B	3K	6.2K

Note

- For additional impedance codes, refer to the Dual Terminator Impedance Code Table document (www.vishay.com/doc?31530).

CIRCUIT APPLICATIONS

01 Schematic

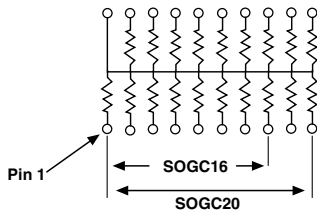

15 or 19 resistors with one pin common
 The SOGCxx01 circuit provides a choice of 15 or 19 nominally equal resistors, each connected between a common lead (16 or 20) and a discrete PC board pin. Commonly used in the following applications:

- MOS/ROM pull-up/pull-down
- Open collector pull-up
- "Wired OR" pull-up
- Power driven pull-up
- TTL input pull-down
- Digital pulse squaring
- TTL unused gate pull-up
- High speed parallels pull-up

03 Schematic

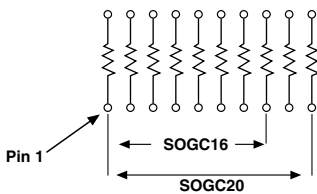

8 or 10 isolated resistors
 The SOGCxx03 circuit provides a choice of 8 or 10 nominally equal resistors with each resistor isolated from all others and wired directly across. Commonly used in the following applications:

- "Wired OR" pull-up
- Power driven pull-up
- Powergate pull-up
- Line termination
- Long-line Impedance balancing
- LED current limiting
- ECL output pull-down
- TTL input pull-down

05 Schematic

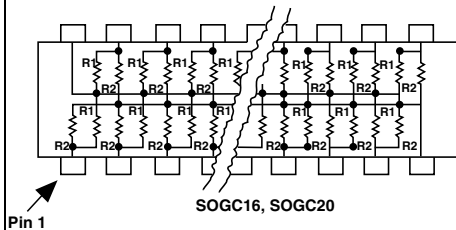

TTL dual-line terminator; pulse squaring, 14 or 18 pairs of resistors
 (R_1 resistors are common to leads 16 or 20)
 (R_2 resistors are common to leads 8 or 10)
 The SOGCxx05 circuit contains 14 or 18 pairs of resistors. Each pair is connected between ground and a common line. The junctions of these resistor pairs are connected to the input leads.
 The 05 circuits are designed for TTL dual-line termination and pulse squaring.

DERATING

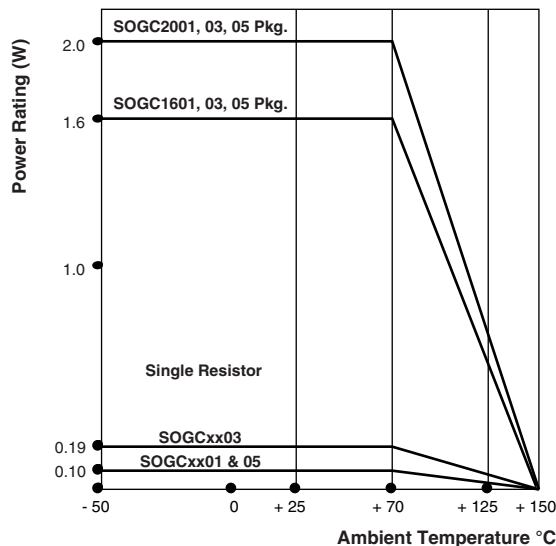



PERFORMANCE	
TEST	MAX. ΔR (TYPICAL TEST LOTS)
Power conditioning	$\pm 0.50\% \Delta R$
Thermal shock	$\pm 0.50\% \Delta R$
Short time overload	$\pm 0.25\% \Delta R$
Low temperature operation	$\pm 0.25\% \Delta R$
Moisture resistance	$\pm 0.50\% \Delta R$
Resistance to soldering heat	$\pm 0.25\% \Delta R$
Shock	$\pm 0.25\% \Delta R$
Vibration	$\pm 0.25\% \Delta R$
Load life	$\pm 0.50\% \Delta R$
Terminal strength	$\pm 0.25\% \Delta R$
Insulation resistance	10 000 M Ω (minimum)
Dielectric withstanding voltage	No evidence of arcing or damage (200 V _{RMS} for 1 min)



Disclaimer

ALL PRODUCT, PRODUCT SPECIFICATIONS AND DATA ARE SUBJECT TO CHANGE WITHOUT NOTICE TO IMPROVE RELIABILITY, FUNCTION OR DESIGN OR OTHERWISE.

Vishay Intertechnology, Inc., its affiliates, agents, and employees, and all persons acting on its or their behalf (collectively, "Vishay"), disclaim any and all liability for any errors, inaccuracies or incompleteness contained in any datasheet or in any other disclosure relating to any product.

Vishay makes no warranty, representation or guarantee regarding the suitability of the products for any particular purpose or the continuing production of any product. To the maximum extent permitted by applicable law, Vishay disclaims (i) any and all liability arising out of the application or use of any product, (ii) any and all liability, including without limitation special, consequential or incidental damages, and (iii) any and all implied warranties, including warranties of fitness for particular purpose, non-infringement and merchantability.

Statements regarding the suitability of products for certain types of applications are based on Vishay's knowledge of typical requirements that are often placed on Vishay products in generic applications. Such statements are not binding statements about the suitability of products for a particular application. It is the customer's responsibility to validate that a particular product with the properties described in the product specification is suitable for use in a particular application. Parameters provided in datasheets and/or specifications may vary in different applications and performance may vary over time. All operating parameters, including typical parameters, must be validated for each customer application by the customer's technical experts. Product specifications do not expand or otherwise modify Vishay's terms and conditions of purchase, including but not limited to the warranty expressed therein.

Except as expressly indicated in writing, Vishay products are not designed for use in medical, life-saving, or life-sustaining applications or for any other application in which the failure of the Vishay product could result in personal injury or death. Customers using or selling Vishay products not expressly indicated for use in such applications do so at their own risk. Please contact authorized Vishay personnel to obtain written terms and conditions regarding products designed for such applications.

No license, express or implied, by estoppel or otherwise, to any intellectual property rights is granted by this document or by any conduct of Vishay. Product names and markings noted herein may be trademarks of their respective owners.

Material Category Policy

Vishay Intertechnology, Inc. hereby certifies that all its products that are identified as RoHS-Compliant fulfill the definitions and restrictions defined under Directive 2011/65/EU of The European Parliament and of the Council of June 8, 2011 on the restriction of the use of certain hazardous substances in electrical and electronic equipment (EEE) - recast, unless otherwise specified as non-compliant.

Please note that some Vishay documentation may still make reference to RoHS Directive 2002/95/EC. We confirm that all the products identified as being compliant to Directive 2002/95/EC conform to Directive 2011/65/EU.

Vishay Intertechnology, Inc. hereby certifies that all its products that are identified as Halogen-Free follow Halogen-Free requirements as per JEDEC JS709A standards. Please note that some Vishay documentation may still make reference to the IEC 61249-2-21 definition. We confirm that all the products identified as being compliant to IEC 61249-2-21 conform to JEDEC JS709A standards.

X-ON Electronics

Largest Supplier of Electrical and Electronic Components

Click to view similar products for [Resistor Networks & Arrays](#) category:

Click to view products by [Vishay](#) manufacturer:

Other Similar products are found below :

[M8340105K1002FGD03](#) [M8340105K3301JCD03](#) [M8340106M2002GCD03](#) [M8340107K1471FGD03](#) [M8340107K2002GCD03](#)
[M8340107K2261FGD03](#) [M8340107M1501GGD03](#) [M8340108K1001FCD03](#) [M8340108K3240FGD03](#) [M8340108K4991FGD03](#)
[M8340108K6192FGD03](#) [M8340109K2872FCD03](#) [M8340109MA010GHD03](#) [EXB-24N121JX](#) [EXB-24N330JX](#) [EXB-24N470JX](#)
[744C083101JTR](#) [EXB-U14360JX](#) [EXB-U18390JX](#) [744C083270JTR](#) [745C102472JP](#) [767161104G](#) [770101223](#) [ACAS06S0830339P100](#)
[ACAS06S0830343P100](#) [ACAS06S0830344P100](#) [RM2012A-102/104-PBVW10](#) [RM2012A-102503-PBVW10](#) [8B472TR4](#) [268-15K](#)
[ACAS06S0830341P100](#) [ACAS06S0830342P100](#) [ACAS06S0830345P100](#) [EXB-U14470JX](#) [EXB-U18330JX](#) [266-10K](#)
[M8340102K1051FBD04](#) [M8340105M1001JCD03](#) [M8340106K4701GGD03](#) [M8340107K1004GGD03](#) [M8340108K1000GGD03](#)
[M8340108K1202GGD03](#) [M8340108K3901GGD03](#) [M8340108K4992FGD03](#) [M8340108K5111FGD03](#) [M8340109K2202GCD03](#)
[RKC8BD104J](#) [DFNA100-1TS](#) [745X101473JP](#) [RMKD408-10KBW](#)