

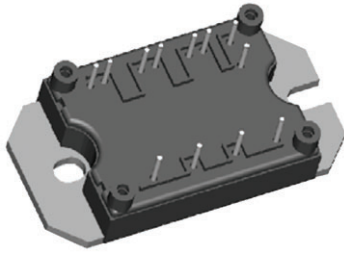

“Half Bridge” IGBT MTP (Warp Speed IGBT), 114 A

MTP

FEATURES

- Gen 4 warp speed IGBT technology
- HEXFRED® antiparallel diodes with ultrasoft reverse recovery
- Very low conduction and switching losses
- Optional SMD thermistor (NTC)
- Very low junction to case thermal resistance
- UL approved file E78996 
- Designed and qualified for industrial level
- Material categorization: for definitions of compliance please see www.vishay.com/doc?99912

**RoHS
COMPLIANT**

PRIMARY CHARACTERISTICS	
V_{CES}	600 V
$V_{CE(on)}$ typical at $V_{GE} = 15$ V	2.3 V
I_C at $T_C = 25$ °C	114 A
Speed	30 kHz to 100 kHz
Package	MTP
Circuit configuration	Half bridge

BENEFITS

- Optimized for welding, UPS and SMPS applications
- Low EMI, requires less snubbing
- Direct mounting to heatsink
- PCB solderable terminals
- Very low stray inductance design for high speed operation

ABSOLUTE MAXIMUM RATINGS				
PARAMETER	SYMBOL	TEST CONDITIONS	MAX.	UNITS
Collector to emitter voltage	V_{CES}		600	V
Continuous collector current	I_C	$T_C = 25$ °C	114	A
		$T_C = 109$ °C	50	
Pulsed collector current	I_{CM}		350	
Peak switching current	I_{LM}		350	
Diode continuous forward current	I_F	$T_C = 109$ °C	34	
Peak diode forward current	I_{FM}		200	
Gate to emitter voltage	V_{GE}		± 20	
RMS isolation voltage	V_{ISOL}	Any terminal to case, $t = 1$ min	2500	
Maximum power dissipation	P_D	$T_C = 25$ °C	658	W
		$T_C = 100$ °C	263	

ELECTRICAL SPECIFICATIONS ($T_J = 25$ °C unless otherwise specified)						
PARAMETER	SYMBOL	TEST CONDITIONS	MIN.	TYP.	MAX.	UNITS
Collector to emitter breakdown voltage	$V_{(BR)CES}$	$V_{GE} = 0$ V, $I_C = 500$ μ A	600	-	-	V
Collector to emitter voltage	$V_{CE(on)}$	$V_{GE} = 15$ V, $I_C = 50$ A	-	2.3	3.15	V
		$V_{GE} = 15$ V, $I_C = 100$ A	-	2.5	3.2	
		$V_{GE} = 15$ V, $I_C = 50$ A, $T_J = 150$ °C	-	1.72	2.17	
Gate threshold voltage	$V_{GE(th)}$	$I_C = 0.5$ mA	3	-	6	
Collector to emitter leaking current	I_{CES}	$V_{GE} = 0$ V, $I_C = 600$ A	-	-	0.4	mA
		$V_{GE} = 0$ V, $I_C = 600$ A, $T_J = 150$ °C	-	-	10	
Diode forward voltage drop	V_{FM}	$I_F = 50$ A, $V_{GE} = 0$ V	-	1.58	1.80	V
		$I_F = 50$ A, $V_{GE} = 0$ V, $T_J = 150$ °C	-	1.49	1.68	
		$I_F = 100$ A, $V_{GE} = 0$ V, $T_J = 25$ °C	-	1.9	2.17	
Gate to emitter leakage current	I_{GES}	$V_{GE} = \pm 20$ V	-	-	± 250	nA



SWITCHING CHARACTERISTICS (T _J = 25 °C unless otherwise specified)						
PARAMETER	SYMBOL	TEST CONDITIONS	MIN.	TYP.	MAX.	UNITS
Total gate charge (turn-on)	Q _g	I _C = 52 A V _{CC} = 400 V V _{GE} = 15 V	-	331	385	nC
Gate to emitter charge (turn-on)	Q _{ge}		-	44	52	
Gate to collector charge (turn-on)	Q _{gc}		-	133	176	
Turn-on switching loss	E _{on}	Internal gate resistors (see electrical diagram) I _C = 50 A, V _{CC} = 480 V, V _{GE} = 15 V, L = 200 μH energy losses include tail and diode reverse recovery, T _J = 25 °C	-	0.26	-	mJ
Turn-off switching loss	E _{off}		-	1.2	-	
Total switching loss	E _{ts}		-	1.46	-	
Turn-on switching loss	E _{on}	Internal gate resistors (see electrical diagram) I _C = 50 A, V _{CC} = 480 V, V _{GE} = 15 V, L = 200 μH energy losses include tail and diode reverse recovery, T _J = 150 °C	-	0.73	-	mJ
Turn-off switching loss	E _{off}		-	1.66	-	
Total switching loss	E _{ts}		-	2.39	-	
Input capacitance	C _{ies}	V _{GE} = 0 V V _{CC} = 30 V f = 1.0 MHz	-	7100	-	pF
Output capacitance	C _{oes}		-	510	-	
Reverse transfer capacitance	C _{res}		-	140	-	
Diode reverse recovery time	t _{rr}	V _{CC} = 200 V, I _C = 50 A dI/dt = 200 A/μs	-	82	97	ns
Diode peak reverse current	I _{rr}		-	8.3	10.6	A
Diode recovery charge	Q _{rr}		-	340	514	nC
Diode reverse recovery time	t _{rr}	V _{CC} = 200 V, I _C = 50 A dI/dt = 200 A/μs T _J = 125 °C	-	137	153	ns
Diode peak reverse current	I _{rr}		-	12.7	14.8	A
Diode recovery charge	Q _{rr}		-	870	1132	nC

THERMISTOR SPECIFICATIONS						
PARAMETER	SYMBOL	TEST CONDITIONS	MIN.	TYP.	MAX.	UNITS
Resistance	R ₀ ⁽¹⁾	T ₀ = 25 °C	-	30	-	kΩ
Sensitivity index of the thermistor material	β ⁽¹⁾⁽²⁾	T ₀ = 25 °C T ₁ = 85 °C	-	4000	-	K

Notes

(1) T₀, T₁ are thermistor's temperatures

(2) $\frac{R_0}{R_1} = \exp\left[\beta\left(\frac{1}{T_0} - \frac{1}{T_1}\right)\right]$, temperature in Kelvin

THERMAL AND MECHANICAL SPECIFICATIONS						
PARAMETER	SYMBOL	TEST CONDITIONS	MIN.	TYP.	MAX.	UNITS
Operating junction temperature range	IGBT, diode Thermistor	T _J	-40	-	150	°C
			-40	-	125	
Storage temperature range	T _{Stg}		-40	-	125	
Junction to case	IGBT Diode	R _{thJC}	-	-	0.38	°C/W
			-	-	0.8	
Case to sink per module	R _{thCS}	Heatsink compound thermal conductivity = 1 W/mK	-	0.06	-	
Clearance ⁽¹⁾		External shortest distance in air between 2 terminals	5.5	-	-	
Creepage ⁽¹⁾		Shortest distance along the external surface of the insulating material between 2 terminals	8	-	-	mm
Mounting torque to heatsink		A mounting compound is recommended and the torque should be checked after 3 hours to allow for the spread of the compound. Lubricated threads.	3 ± 10 %			Nm
Weight			66			g

Note

(1) Standard version only i.e. without optional thermistor

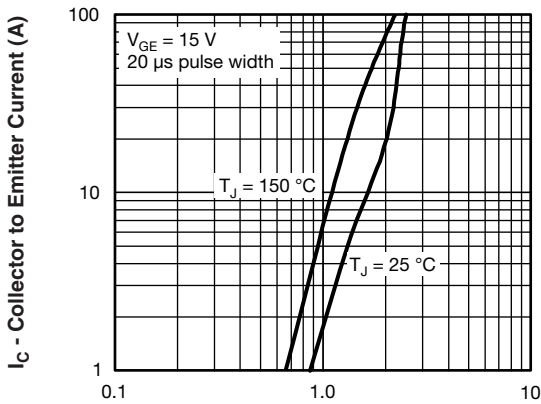

94468_01 V_{CE} - Collector to Emitter Voltage (V)

Fig. 1 - Typical Output Characteristics

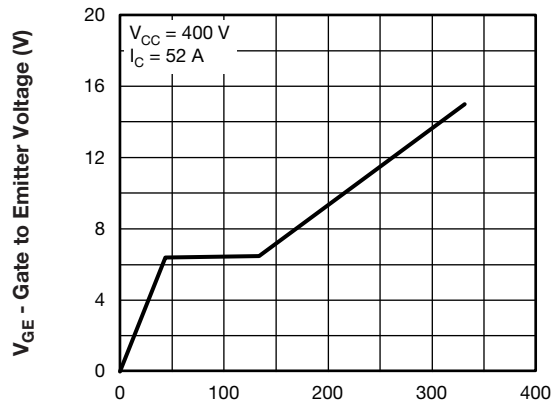

94468_04 Q_G - Typical Gate Charge (nC)

Fig. 4 - Typical Gate Charge vs. Gate to Emitter Voltage

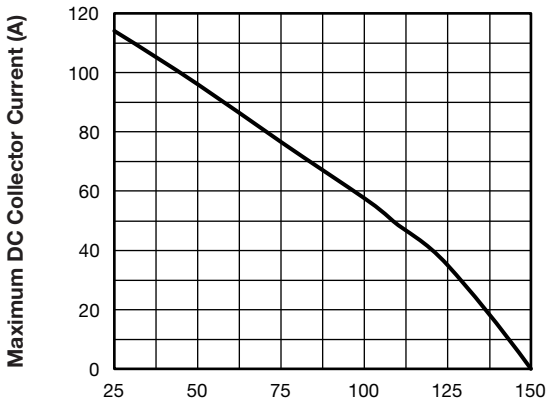

94468_02 T_C - Case Temperature (°C)

Fig. 2 - Maximum Collector Current vs. Case Temperature

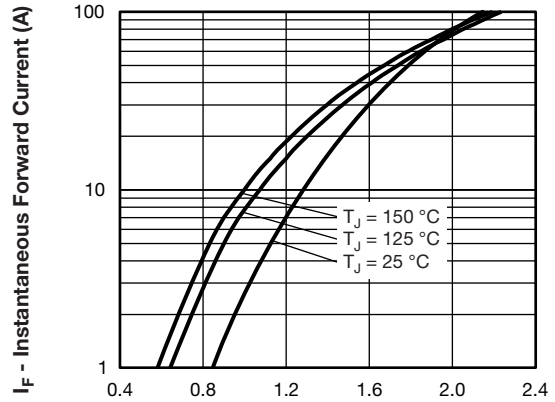

94468_05 V_{FM} - Forward Voltage Drop (V)

Fig. 5 - Maximum Forward Voltage Drop vs. Instantaneous Forward Current

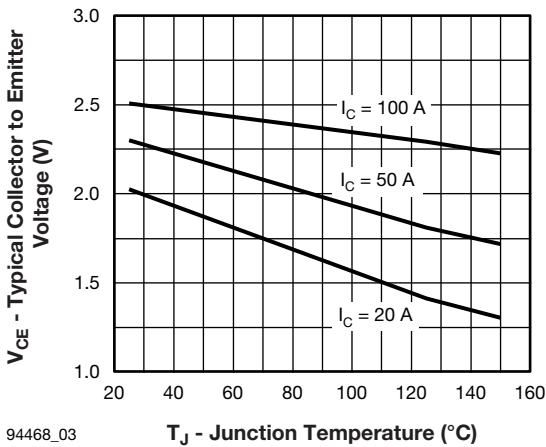

94468_03 T_J - Junction Temperature (°C)

Fig. 3 - Typical Collector to Emitter Voltage vs. Junction Temperature

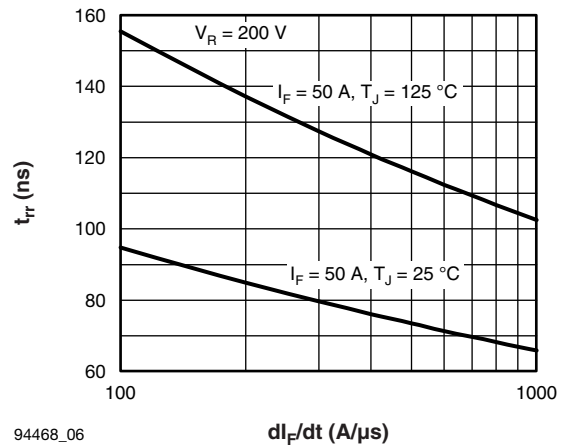

94468_06 dI_F/dt (A/μs)

Fig. 6 - Typical Reverse Recovery Time vs. dI_F/dt

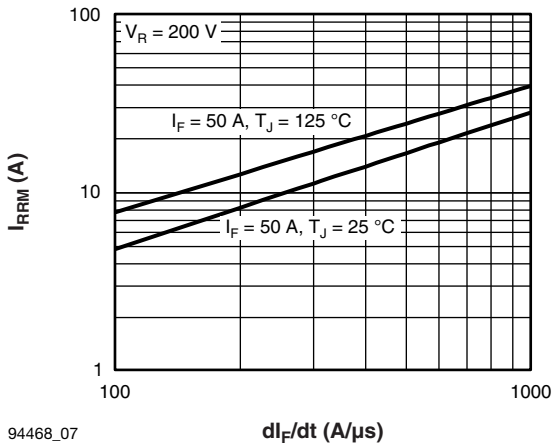

94468_07

Fig. 7 - Typical Reverse Recovery Current vs. di_F/dt

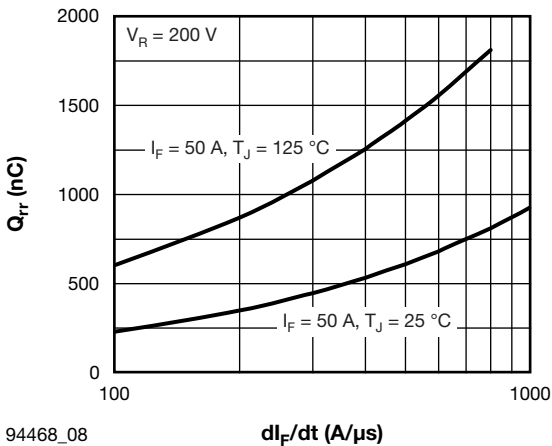

94468_08

Fig. 8 - Typical Stored Charge vs. di_F/dt

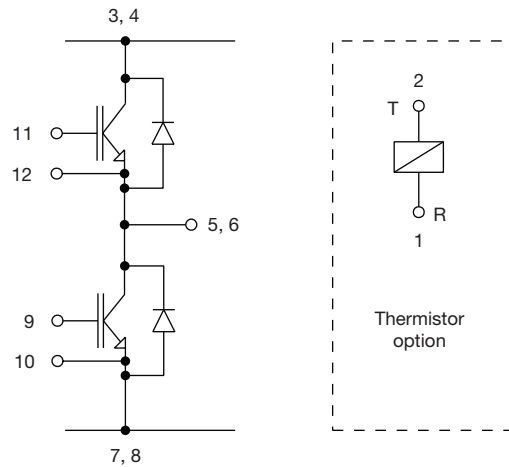

Fig. 9 - Functional Diagram

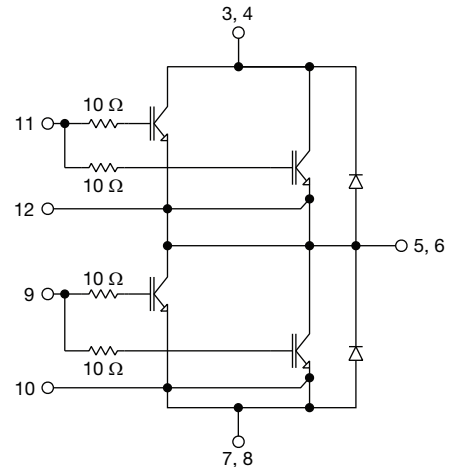

Fig. 10 - Electrical Diagram

ORDERING INFORMATION TABLE

Device code	VS-	50	MT	060	W	H	T	A	PbF
	①	②	③	④	⑤	⑥	⑦	⑧	⑨
1	-	Vishay Semiconductors product							
2	-	Current rating (50 = 50 A)							
3	-	Essential part number							
4	-	Voltage rating (060 = 600 V)							
5	-	Speed / type (W = warp IGBT)							
6	-	Circuit configuration (H = half bridge)							
7	-	T = thermistor							
8	-	A = Al ₂ O ₃ substrate							
9	-	Lead (Pb)-free							



CIRCUIT CONFIGURATION

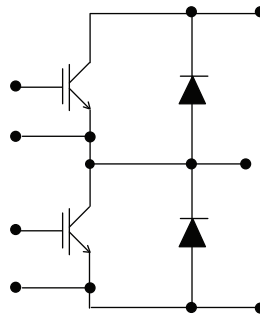

LINKS TO RELATED DOCUMENTS

LINKS TO RELATED DOCUMENTS	
Dimensions	www.vishay.com/doc?95175



Disclaimer

ALL PRODUCT, PRODUCT SPECIFICATIONS AND DATA ARE SUBJECT TO CHANGE WITHOUT NOTICE TO IMPROVE RELIABILITY, FUNCTION OR DESIGN OR OTHERWISE.

Vishay Intertechnology, Inc., its affiliates, agents, and employees, and all persons acting on its or their behalf (collectively, "Vishay"), disclaim any and all liability for any errors, inaccuracies or incompleteness contained in any datasheet or in any other disclosure relating to any product.

Vishay makes no warranty, representation or guarantee regarding the suitability of the products for any particular purpose or the continuing production of any product. To the maximum extent permitted by applicable law, Vishay disclaims (i) any and all liability arising out of the application or use of any product, (ii) any and all liability, including without limitation special, consequential or incidental damages, and (iii) any and all implied warranties, including warranties of fitness for particular purpose, non-infringement and merchantability.

Statements regarding the suitability of products for certain types of applications are based on Vishay's knowledge of typical requirements that are often placed on Vishay products in generic applications. Such statements are not binding statements about the suitability of products for a particular application. It is the customer's responsibility to validate that a particular product with the properties described in the product specification is suitable for use in a particular application. Parameters provided in datasheets and / or specifications may vary in different applications and performance may vary over time. All operating parameters, including typical parameters, must be validated for each customer application by the customer's technical experts. Product specifications do not expand or otherwise modify Vishay's terms and conditions of purchase, including but not limited to the warranty expressed therein.

Except as expressly indicated in writing, Vishay products are not designed for use in medical, life-saving, or life-sustaining applications or for any other application in which the failure of the Vishay product could result in personal injury or death. Customers using or selling Vishay products not expressly indicated for use in such applications do so at their own risk. Please contact authorized Vishay personnel to obtain written terms and conditions regarding products designed for such applications.

No license, express or implied, by estoppel or otherwise, to any intellectual property rights is granted by this document or by any conduct of Vishay. Product names and markings noted herein may be trademarks of their respective owners.

X-ON Electronics

Largest Supplier of Electrical and Electronic Components

Click to view similar products for [IGBT Modules category](#):

Click to view products by [Vishay manufacturer](#):

Other Similar products are found below :

[F3L400R07ME4_B22](#) [F4-50R07W2H3_B51](#) [FB15R06W1E3](#) [FB20R06W1E3_B11](#) [FD1000R33HE3-K](#) [FD400R12KE3](#) [FD400R33KF2C-K](#)
[FD401R17KF6C_B2](#) [FD-DF80R12W1H3_B52](#) [FF200R06YE3](#) [FF300R12KE4_E](#) [FF450R12ME4P](#) [FF600R12IP4V](#) [FP15R12W2T4](#)
[FP20R06W1E3](#) [FP50R12KT3](#) [FP75R07N2E4_B11](#) [FS10R12YE3](#) [FS150R07PE4](#) [FS150R12PT4](#) [FS200R12KT4R](#) [FS20R06W1E3_B11](#)
[FS50R07N2E4_B11](#) [FZ1000R33HE3](#) [FZ1800R17KF4](#) [DD250S65K3](#) [DF1000R17IE4](#) [DF1000R17IE4D_B2](#) [DF1400R12IP4D](#)
[DF200R12PT4_B6](#) [DF400R07PE4R_B6](#) [BSM75GB120DN2_E3223c-Se](#) [F3L300R12ME4_B22](#) [F3L75R07W2E3_B11](#) [F4-50R12KS4_B11](#)
[FD1400R12IP4D](#) [FD200R12PT4_B6](#) [FD800R33KF2C-K](#) [FF150R12ME3G](#) [FF300R17KE3_S4](#) [FF300R17ME4_B11](#) [FF401R17KF6C_B2](#)
[FF650R17IE4D_B2](#) [FF900R12IP4D](#) [FF900R12IP4DV](#) [FP50R07N2E4_B11](#) [FS100R07PE4](#) [FS150R07N3E4_B11](#) [FS150R17N3E4](#)
[FS150R17PE4](#)