

Conformal, Single In-Line Resistor Networks (Custom)

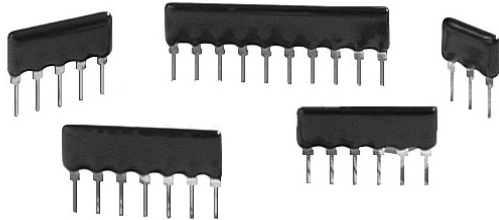

Wirewound or metal film performance in a space saving package.

SIP networks available in 3 - 10 pin sizes can obtain important performance parameters in an economical, mass producible style. SIPs take up the least amount of board space and are the easiest possible configuration to hand-insert into printed circuit boards. Standard pin centers are 0.100". Passivation coatings plus a conformal coating of epoxy protect the active element from the outside environment.

FEATURES

- Lead (Pb)-free available
- Minimal PC board space
- Standard 100 mil centers
- Exceptional stability over time and temperature (500 ppm at + 70 °C at 2000 hours)
- Integrated construction
- Conformal coating flame resistant (UL94V-0 rating)



TYPICAL PERFORMANCE

	ABS	TRACKING
TCR	10	2
	ABS	RATIO
TOL	0.05	0.02

SCHEMATIC

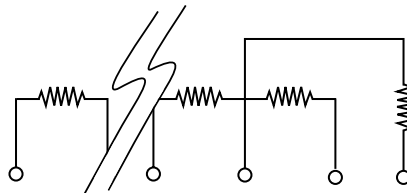

Custom schematics available. Please consult factory

THROUGH HOLE

STANDARD ELECTRICAL SPECIFICATIONS			
TEST		SPECIFICATIONS	CONDITIONS
Material		Passivated Nichrome	
Resistance Range		20 Ω to 2 MΩ total	
TCR:	Tracking	± 5 ppm/°C to ± 2 ppm/°C	- 55 °C to + 125 °C
	Absolute	± 25 ppm/°C to + 10 ppm/°C	- 55 °C to + 125 °C
Tolerance:	Ratio	± 0.5 % to ± 0.01 %	+ 25 °C
	Absolute	± 1.0 % to ± 0.05 %	+ 25 °C
Power Rating:	Resistor	100 mW per element	Max. at + 70 °C
Stability:	ΔR Absolute	500 ppm	2000 h at + 70 °C
	ΔR Ratio	150 ppm	2000 h at + 70 °C
Voltage Coefficient		< 0.1 ppm/Volt	
Working Voltage		100 Volts	
Operating Temperature Range		- 55 °C to + 125 °C	
Storage Temperature Range		- 55 °C to + 150 °C	
Noise		< - 30 dB	
Thermal EMF		< 0.10 μV/°C	
Shelf Life Stability:	Absolute	< 100 ppm	1 year at + 25 °C
	Ratio	20 ppm	1 year at + 25 °C

* Pb containing terminations are not RoHS compliant, exemptions may apply

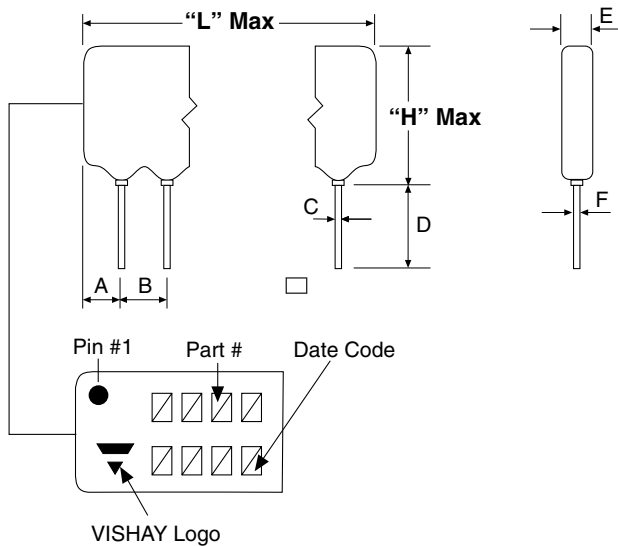
DIMENSIONS AND IMPRINTING in inches and millimeters

DIMENSION	INCHES	MM
A	0.058 Typ.	1.47 Typ.
B	0.100 Typ.	2.54 Typ.
C	0.020 ± 0.003	0.51 ± 0.08
D	0.125 Min.	3.18 Min.
E	0.110 Max.	2.79 Max.
F	0.010 Typ.	0.25 Typ.

NUMBER OF PINS	LENGTH (L)		HEIGHT (H)	
	INCHES	MM	INCHES	MM
3	0.320	8.13		
4	0.420	10.67		
5	0.520	13.21		
6	0.620	15.75	0.280*	7.11*
7	0.720	18.29		
8	0.820	20.83		
9	0.920	23.37		
10	1.020	25.91		

* H dimension, R-Value and Schematic dependent

MECHANICAL SPECIFICATIONS	
Resistive Elements	Passivated Nichrome
Substrate Material	Alumina
Body	Epoxy
Terminals	Copper
Plating	Sn60
Marking Resistance to Solvents	per MIL-PRF-8340
Lead (Pb)-free Option	96.5 % Sn, 3.0 % Ag, 0.5 % Cu
Lead (Pb)-free Finish	Hot Solder Dip

ORDERING INFORMATION CHECK LIST (CUSTOMS)	
Special requirements should be identified in advance, but as a minimum, you should have the following information ready.	
ELECTRICAL	MECHANICAL
<ol style="list-style-type: none"> Resistors, by value and tolerance Reference resistor(s) and matching of which resistors to which reference resistors Resistance by ratio Absolute temperature coefficient of resistivity Temperature tracking of subordinate resistors to reference resistor(s) Maximum operating voltage Resistor power ratings Operating temperature range 	<ol style="list-style-type: none"> Maximum allowable seated height (from PC board to top of network) Special marking concerns Schematic pin out of package Specify if lead (Pb)-free
For additional assistance refer to VISHAY Thin Film's Guide to Understanding Thin Film Precision, Resistor Networks or call Applications Engineering. All standard products may be ordered directly from VISHAY Thin Film.	



GLOBAL PART NUMBER INFORMATION

New Global Part Numbering: VTF211BX (preferred part number format)

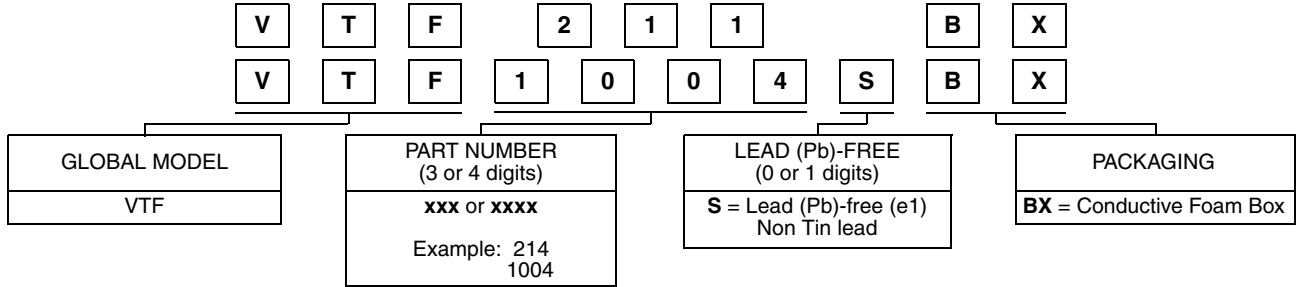

Historical Part Number example: VTF Custom 211 (will continue to be accepted)



THROUGH HOLE



Disclaimer

All product specifications and data are subject to change without notice.

Vishay Intertechnology, Inc., its affiliates, agents, and employees, and all persons acting on its or their behalf (collectively, "Vishay"), disclaim any and all liability for any errors, inaccuracies or incompleteness contained herein or in any other disclosure relating to any product.

Vishay disclaims any and all liability arising out of the use or application of any product described herein or of any information provided herein to the maximum extent permitted by law. The product specifications do not expand or otherwise modify Vishay's terms and conditions of purchase, including but not limited to the warranty expressed therein, which apply to these products.

No license, express or implied, by estoppel or otherwise, to any intellectual property rights is granted by this document or by any conduct of Vishay.

The products shown herein are not designed for use in medical, life-saving, or life-sustaining applications unless otherwise expressly indicated. Customers using or selling Vishay products not expressly indicated for use in such applications do so entirely at their own risk and agree to fully indemnify Vishay for any damages arising or resulting from such use or sale. Please contact authorized Vishay personnel to obtain written terms and conditions regarding products designed for such applications.

Product names and markings noted herein may be trademarks of their respective owners.

X-ON Electronics

Largest Supplier of Electrical and Electronic Components

Click to view similar products for [Resistor Networks & Arrays](#) category:

Click to view products by [Vishay](#) manufacturer:

Other Similar products are found below :

[M8340105K1002FGD03](#) [M8340105K3301JCD03](#) [M8340106M2002GCD03](#) [M8340107K1471FGD03](#) [M8340107K2002GCD03](#)
[M8340107K2261FGD03](#) [M8340107M1501GGD03](#) [M8340108K1001FCD03](#) [M8340108K3240FGD03](#) [M8340108K4991FGD03](#)
[M8340108K6192FGD03](#) [M8340109MA010GHD03](#) [EXB-24N121JX](#) [EXB-24N330JX](#) [EXB-24N470JX](#) [744C083101JTR](#) [EXB-U14360JX](#)
[EXB-U18390JX](#) [744C083270JTR](#) [745C102472JP](#) [767161104G](#) [770101223](#) [ACAS06S0830339P100](#) [ACAS06S0830343P100](#)
[ACAS06S0830344P100](#) [RM2012A-102/104-PBVW10](#) [RM2012A-102503-PBVW10](#) [8B472TR4](#) [268-15K](#) [ACAS06S0830341P100](#)
[ACAS06S0830342P100](#) [ACAS06S0830345P100](#) [EXB-U14470JX](#) [EXB-U18330JX](#) [266-10K](#) [M8340102K1051FBD04](#)
[M8340105M1001JCD03](#) [M8340106K4701GGD03](#) [M8340107K1004GGD03](#) [M8340108K1000GGD03](#) [M8340108K1202GGD03](#)
[M8340108K3901GGD03](#) [M8340108K4992FGD03](#) [M8340108K5111FGD03](#) [M8340109K2202GCD03](#) [RKC8BD104J](#) [DFNA100-1TS](#)
[745X101473JP](#) [RMKD408-10KBW](#) [MDP16-03-3K01FE04](#)