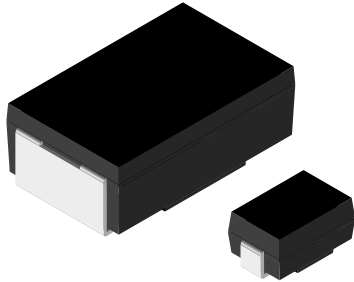

Metal Film Resistors, Power, Surface Mount

Note

* This datasheet provides information about parts that are RoHS-compliant and / or parts that are non RoHS-compliant. For example, parts with lead (Pb) terminations are not RoHS-compliant. Please see the information / tables in this datasheet for details

FEATURES

- Molded encapsulation
- Wraparound compliant terminations eliminate risk of solder fillet cracking
- Solderable terminations
- Excellent stability at different environmental conditions
- High power ratings (up to 2 W)
- AEC-Q200 qualified ⁽¹⁾
- Material categorization: for definitions of compliance please see www.vishay.com/doc?99912

Note

- ⁽¹⁾ Flame retardance test may not be applicable to some resistor technologies

STANDARD ELECTRICAL SPECIFICATIONS

GLOBAL MODEL	SIZE INCH	POWER RATING $P_{70^\circ\text{C}}$ W	TOLERANCE $\pm \%$	RESISTANCE RANGE Ω	TEMPERATURE COEFFICIENT ⁽²⁾ $\pm \text{ppm}/^\circ\text{C}$	ENCAPSULATION
WSF2012	2012	0.5	0.5, 1, 5	5.0 to 1.43K ⁽¹⁾	100	Epoxy
WSF2515	2515	1.0	0.5, 1, 5	10 to 10K	100	Thermoplastic
WSF4527	4527	2.0 ⁽³⁾	0.5, 1, 5	10 to 100K	100	Thermoplastic

Notes

- WSF2012 has been obsolete; PTN-DR-00013-2018 Rev. 0 - July 20, 2018. WSF2515 and WSF4527 sizes are **not** affected
- ⁽¹⁾ E96 values only
- ⁽²⁾ $\pm 50 \text{ ppm}/^\circ\text{C}$ and $\pm 25 \text{ ppm}/^\circ\text{C}$ available
- ⁽³⁾ Resistance values above 31.25 k Ω are limited to 250 V maximum working voltage

TECHNICAL SPECIFICATIONS

PARAMETER	UNIT	WSF2012	WSF2515	WSF4527
Dielectric withstanding voltage	V_{AC}	> 500	> 500	> 500
Insulation resistance	Ω		$> 10^9$	
Operating temperature range	$^\circ\text{C}$	-65 / +175	-65 / +175	-65 / +150
Maximum working voltage	V	$(P \times R)^{1/2}$	$(P \times R)^{1/2}$	$(P \times R)^{1/2}$ ⁽¹⁾
Weight/1000 pieces (typical)	g	90	165	760

Notes

- Part marking: 1/2 W - DALE, value; 1 W - model, value, tolerance, date code; 2 W - DALE, model, value, tolerance, date code
- ⁽¹⁾ Resistance values above 31.25 k Ω are limited to 250 V maximum working voltage

GLOBAL PART NUMBER INFORMATION

Global Part Numbering example: WSF25151K500JKTA (preferred numbering format)

W	S	F	2	5	1	5	1	K	5	0	0	J	K	T	A		
GLOBAL MODEL			VALUE			TOLERANCE			TCR			PACKAGING			SPECIAL		
WSF2515 WSF4527			R = decimal K = thousand 100R0 = 100 Ω 1K000 = 1 k Ω			D = $\pm 0.5 \%$ F = $\pm 1.0 \%$ G = $\pm 2.0 \%$ H = $\pm 3.0 \%$ J = $\pm 5.0 \%$ K = $\pm 10 \%$			E = $\pm 25 \text{ ppm}/^\circ\text{C}$ H = $\pm 50 \text{ ppm}/^\circ\text{C}$ K = $\pm 100 \text{ ppm}/^\circ\text{C}$			EA = lead (Pb)-free, tape / reel EK = lead (Pb)-free, bulk TA = tin / lead, tape / reel (R86) BA = tin / lead, tape / reel, bulk (B43)			(dash number) (up to 2 digits) from 1 to 99 as applicable		

Historical Part Numbering example: WSF2515 1.5 k Ω 5 % 100 ppm/ $^\circ\text{C}$ R86 (will continue to be accepted for tin/lead product only)

WSF2515	1.5 k Ω	5 %	100 ppm/ $^\circ\text{C}$	R86
HISTORICAL MODEL	RESISTANCE VALUE	TOLERANCE CODE	TEMPERATURE COEFFICIENT	PACKAGING

Note

- WSF2012 has been obsolete; PTN-DR-00013-2018 Rev. 0 - July 20, 2018. WSF2515 and WSF4527 sizes are **not** affected

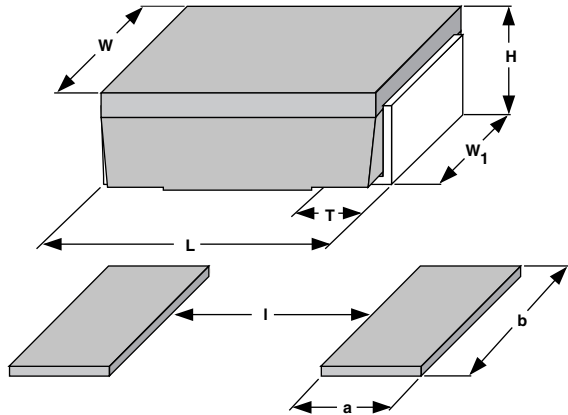
DIMENSIONS

MODEL	DIMENSIONS in inches (millimeters)				
	L	H	T	W	W ₁
WSF2515	0.250 ± 0.020 (6.35 ± 0.508)	0.110 ± 0.015 (2.79 ± 0.381)	0.045 ± 0.010 (1.14 ± 0.254)	0.150 ± 0.005 (3.81 ± 0.127)	0.098 ± 0.005 (2.49 ± 0.127)
WSF4527	0.455 ± 0.020 (11.56 ± 0.508)	0.167 ± 0.010 (4.24 ± 0.254)	0.100 ± 0.010 (2.54 ± 0.254)	0.275 ± 0.005 (6.98 ± 0.127)	0.215 ± 0.005 (5.46 ± 0.127)

MODEL	SOLDER PAD DIMENSIONS in inches (millimeters)		
	a	b	l
WSF2012	0.085 (2.16)	0.070 (1.78)	0.080 (2.03)
WSF2515	0.090 (2.29)	0.115 (2.92)	0.120 (3.05)
WSF4527	0.155 (3.94)	0.230 (5.94)	0.205 (5.21)

Note

- WSF2012 has been obsolete; PTN-DR-00013-2018 Rev. 0 - July 20, 2018. WSF2515 and WSF4527 sizes are **not** affected

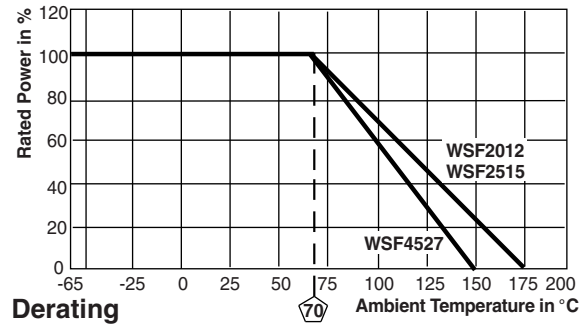
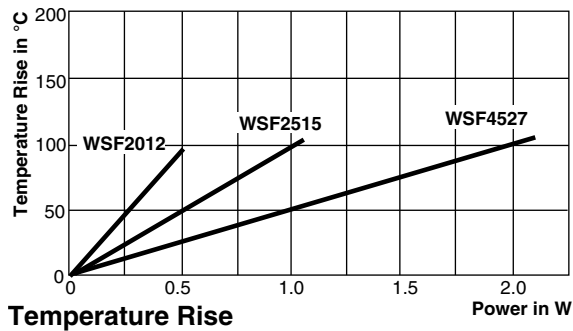

PERFORMANCE		
TEST	CONDITIONS OF TEST	TEST LIMITS
Thermal shock	-55 °C to +150 °C, 1000 cycles, 15 min at each extreme	± (1.0 % + 0.05 Ω) ΔR
Short time overload	5 x rated power for 5 s	± (0.5 % + 0.05 Ω) ΔR
Low temperature storage	-65 °C for 24 h	± (0.5 % + 0.05 Ω) ΔR
High temperature exposure	1000 h at +175 °C (150 °C for WSF4527)	± (1.0 % + 0.05 Ω) ΔR
Bias humidity	+85 °C, 85 % RH, 10 % bias, 1000 h	± (0.5 % + 0.05 Ω) ΔR
Moisture resistance	MIL-STD-202 method 106, 0 % power, 7a and 7b not required	± (0.5 % + 0.05 Ω) ΔR
Mechanical shock	100 g's for 6 ms, 5 pulses	± (0.5 % + 0.05 Ω) ΔR
Vibration	Frequency varied 10 Hz to 500 Hz in one min, 3 directions, 9 h	± (0.5 % + 0.05 Ω) ΔR
Load life	1000 h at rated power, +70 °C, 1.5 h "ON", 0.5 h "OFF"	± (1.0 % + 0.05 Ω) ΔR
Resistance to solder heat	+260 °C solder, 10 s to 12 s dwell, 25 mm/s emergence	± (0.5 % + 0.05 Ω) ΔR

PACKAGING				
MODEL	REEL			
	TAPE WIDTH	DIAMETER	PIECES/REEL	CODE
WSF2515	16 mm / embossed plastic	330 mm / 13"	2000	EA/TA
WSF4527	24 mm / embossed plastic	330 mm / 13"	1200	EA/TA

Notes

- Embossed carrier tape per EIA-481
- WSF2012 has been obsolete; PTN-DR-00013-2018 Rev. 0 - July 20, 2018. WSF2515 and WSF4527 sizes are **not** affected
- Additional packaging details at www.vishay.com/doc?20051



PRODUCT SUMMARY										
SERIES	SIZE / DEVICE STYLE	TCR (± ppm/°C)	TOLERANCE (± %)	RESISTANCE (Ω)		E-SERIES	POWER RATING (W)	TEMP. (°C)	MAX. VOLTAGE (V)	AUTO.
				MIN.	MAX.					
WSF2012	2012	100	0.5	5	1.43K	E96	0.5	-65 to +175	(P x R) ^{1/2}	AGP
WSF2515	2515	100	0.5	10	10K	E96	1	-65 to +175	(P x R) ^{1/2}	AGP
WSF4527	4527	100	0.5	10	100K	E96	2	-65 to +150	(P x R) ^{1/2}	AGP

TAGS	
TYPE	PARAMETER
Mounting technology	SMD
Technology	Metal film
Applications	Automotive, high temperature
Characteristics	-



Disclaimer

ALL PRODUCT, PRODUCT SPECIFICATIONS AND DATA ARE SUBJECT TO CHANGE WITHOUT NOTICE TO IMPROVE RELIABILITY, FUNCTION OR DESIGN OR OTHERWISE.

Vishay Intertechnology, Inc., its affiliates, agents, and employees, and all persons acting on its or their behalf (collectively, "Vishay"), disclaim any and all liability for any errors, inaccuracies or incompleteness contained in any datasheet or in any other disclosure relating to any product.

Vishay makes no warranty, representation or guarantee regarding the suitability of the products for any particular purpose or the continuing production of any product. To the maximum extent permitted by applicable law, Vishay disclaims (i) any and all liability arising out of the application or use of any product, (ii) any and all liability, including without limitation special, consequential or incidental damages, and (iii) any and all implied warranties, including warranties of fitness for particular purpose, non-infringement and merchantability.

Statements regarding the suitability of products for certain types of applications are based on Vishay's knowledge of typical requirements that are often placed on Vishay products in generic applications. Such statements are not binding statements about the suitability of products for a particular application. It is the customer's responsibility to validate that a particular product with the properties described in the product specification is suitable for use in a particular application. Parameters provided in datasheets and / or specifications may vary in different applications and performance may vary over time. All operating parameters, including typical parameters, must be validated for each customer application by the customer's technical experts. Product specifications do not expand or otherwise modify Vishay's terms and conditions of purchase, including but not limited to the warranty expressed therein.

Except as expressly indicated in writing, Vishay products are not designed for use in medical, life-saving, or life-sustaining applications or for any other application in which the failure of the Vishay product could result in personal injury or death. Customers using or selling Vishay products not expressly indicated for use in such applications do so at their own risk. Please contact authorized Vishay personnel to obtain written terms and conditions regarding products designed for such applications.

No license, express or implied, by estoppel or otherwise, to any intellectual property rights is granted by this document or by any conduct of Vishay. Product names and markings noted herein may be trademarks of their respective owners.

X-ON Electronics

Largest Supplier of Electrical and Electronic Components

Click to view similar products for [vishay](#) manufacturer:

Other Similar products are found below :

[M39006/22-0577H](#) [Y00892K49000BR13L](#) [VSKT250-16PBF](#) [M8340109M6801GGD03](#) [NTCALUG01A103F291L](#) [ITU1341SM3](#) [VS-MBRB1545CTPBF](#) [1KAB100E](#) [1KAB20E](#) [CP0005150R0JE1490](#) [S472M69Z5UR84K0R](#) [MKP1848C65090JY5L](#) [562R5GAD47RR](#)
[CRCW1210360RFKEA](#) [VSMF4720-GS08](#) [TSOP34438SS1V](#) [CRCW04024021FRT7](#) [001789X](#) [CRCW08054K00FKTA](#) [LVR10R0200FE03](#)
[CRCW12063K30FKEAHP](#) [009923A](#) [CRCW2010331JR02](#) [CRCW25128K06FKEG](#) [CS6600552K000B8768](#) [CSC07A0110K0GPA](#)
[M34C156K100BZSS](#) [M39003/01-2289](#) [M39003/01-2784](#) [M39006/25-0133](#) [M39006/25-0228](#) [M64W101KB40](#) [M64Z501KB40](#)
[CW001R5000JS73](#) [CW0055R000JE12](#) [CW0056K800JB12](#) [CW0106K000JE73](#) [672D826H075EK5C](#) [CWR06JC105KC](#) [CWR06NC475JC](#)
[MAL219699001E3](#) [MCRL007035R00JHB00](#) [92MT80KPBF](#) [PTF56100K00QYEK](#) [PTN0805H1502BBTR1K](#) [RCWL1210R130JNEA](#)
[RH005220R0FE02](#) [RH005330R0FC02](#) [RH010R0500FC02](#) [132B20103](#)