

## SMD Aluminum Electrolytic Capacitors



### FEATURES

- Polarized aluminum electrolytic capacitors, non-solid electrolyte
- SMD version with base plate, vertical construction, requiring minimum board space
- High CV per unit volume, low impedance, high ripple current
- Ø 4 mm to Ø 18 mm, 105 °C, 2000 h to 5000 h load life
- Material categorization: for definitions of compliance please see [www.vishay.com/doc?99912](http://www.vishay.com/doc?99912)

**RoHS**  
COMPLIANT

### APPLICATIONS

- SMD technology, in compliance with RoHS
- Coupling, decoupling, smoothing, filtering, buffering, timing
- General industrial, portable, and lightweight equipment

### QUICK REFERENCE DATA

DESCRIPTION	UNIT	VALUE
Nominal case sizes (Ø D x L)	mm	4 x 5.7 to 18 x 21.5
Rated capacitance range	µF	1 to 8200
Capacitance tolerance	%	± 20 (at 120 Hz, 20 °C)
Rated voltage range	V <sub>DC</sub>	6.3 to 100
Category temperature range	°C	-55 to +105
Endurance	h	2000 to 5000
Shelf life	h	1000

### ORDERING INFORMATION

Part number example: ZSC00FE2211HARL

ZSC	00	FE	221	1H	AR	L
SERIES NAME	DESIGN / FORMING	DIMENSIONS	CAPACITANCE	VOLTAGE	PACKING	INTERNAL CODE
		See "Dimensions" table	See "Selection Chart"	See "Selection Chart"	Tape and Reel	

**ADDITIONAL ELECTRICAL DATA**

<b>LEAKAGE CURRENT</b> (Test conditions: $U_R$ , 20 °C)			
RATED VOLTAGE	TIME	CASE SIZE	VALUE
6.3 V to 100 V	after 2 min	Ø 4 mm to Ø 18 mm	$I = 0.01 CV$ or 3 µA, whichever is greater

**Notes**

- Where, C = rated capacitance in µF
- V = rated DC working voltage in V

<b>DISSIPATION FACTOR</b> (tan δ at 120 Hz, 20 °C)									
RATED VOLTAGE	6.3	10	16	25	35	50	63	80	100
tan δ (max.)	0.30	0.26	0.22	0.16	0.13	0.10	0.08	0.08	0.07

**Note**

- When the capacitance exceeds 1000 µF, 0.002 shall be added every 1000 µF increase.

<b>LOW TEMPERATURE BEHAVIOR</b> (at 120 Hz)									
IMPEDANCE RATIO	RATED VOLTAGE								
	6.3	10	16	25	35	50	63	80	100
$\frac{Z_{(-25\text{ °C})}}{Z_{(+20\text{ °C})}}$	4	3	2	2	2	2	2	2	2
$\frac{Z_{(-55\text{ °C})}}{Z_{(+20\text{ °C})}}$	8	5	4	3	3	3	3	3	3

<b>MULTIPLIER OF RIPPLE CURRENT AS A FUNCTION OF FREQUENCY</b>	
FREQUENCY (Hz)	CAPACITANCE (µF)
50, 60	0.60
120	0.70
1000	0.85
10 000 and up	1.0

<b>TEST PROCEDURES AND REQUIREMENTS</b>				
TEST	TEST TIME	CAPACITANCE CHANGE	DISSIPATION FACTOR	LEAKAGE CURRENT
Endurance <sup>(1)</sup>	2000 h	Within ± 30 % of initial value for Ø ≤ D 6.3 mm and Ø 10 x 7.7 L	Less than 300 % of specified value	Within specified value
	5000 h	Within ± 30 % of initial value for Ø ≥ D 8 mm		
Shelf life <sup>(2)</sup>	1000 h	Within ± 30 % of initial value		

**Notes**

- (1) The specifications shall be satisfied when the capacitors are restored to 20 °C after the rated voltage applied for 2000 h to 5000 h at 105 °C.
- (2) The above specifications shall be satisfied when the capacitors are restored to 20 °C after exposing them for 1000 h at 105 °C without voltage applied.

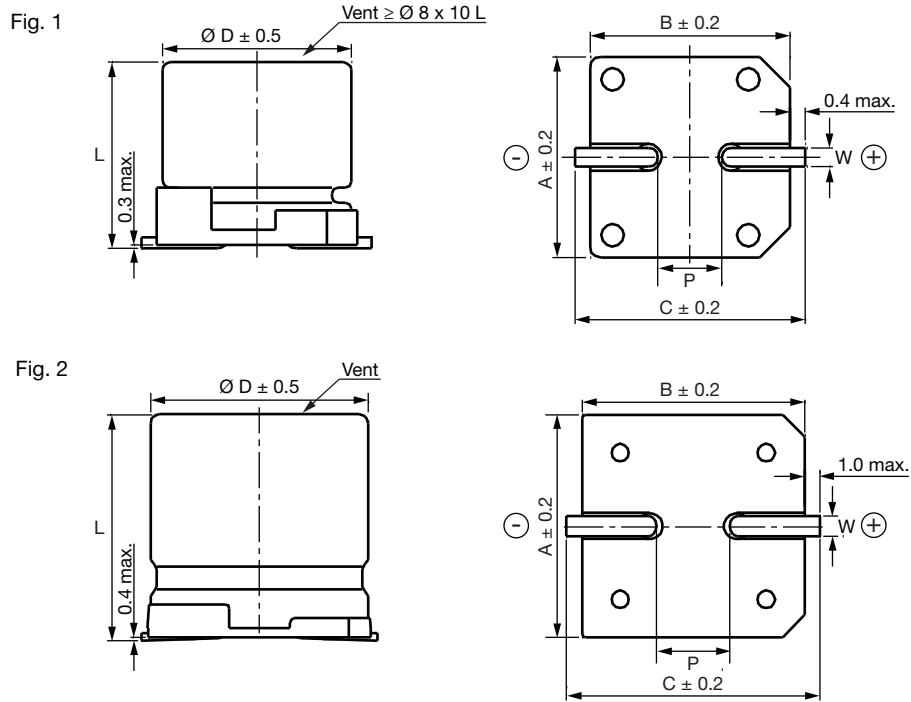
**DIMENSIONS** in millimeters

CASE SIZE CODE	Ø D	L	A	B	C	W	P ± 0.2	FIG. NO.
AB	4 x 5.7	4	5.7 ± 0.3	4.3	4.3	5.1	1.0	1
AC	5 x 5.7	5	5.7 ± 0.3	5.3	5.3	5.9	1.5	1
AD	6.3 x 5.7	6.3	5.7 ± 0.3	6.6	6.6	7.2	2.0	1
BM	6.3 x 7.7	6.3	7.7 ± 0.3	6.6	6.6	7.2	2.0	1
AE	8 x 6.5	8	6.5 ± 0.3	8.4	8.4	9.0	2.3	1
AF	8 x 10	8	10 ± 0.5	8.4	8.4	9.0	3.1	1
XM	10 x 7.7	10	7.7 ± 0.3	10.4	10.4	11.0	4.7	1
AG	10 x 10	10	10 ± 0.5	10.4	10.4	11.0	4.7	1
AH	12.5 x 13.5	12.5	13.5 ± 0.5	13.0	13.0	13.7	4.4	2
CX	12.5 x 16	12.5	16 ± 0.5	13.0	13.0	13.7	4.4	2
AK	16 x 16.5	16	16.5 ± 0.5	17.0	17.0	18.0	6.4	2
AM	16 x 21.5	16	21.5 ± 0.5	17.0	17.0	18.0	6.4	2
AN	18 x 16.5	18	16.5 ± 0.5	19.0	19.0	20.0	6.4	2
AP	18 x 21.5	18	21.5 ± 0.5	19.0	19.0	20.0	6.4	2

**MARKING**

Ø D ≤ 6.3 mm

Ø D = 8 mm to 10 mm

Ø D ≥ 12.5 mm

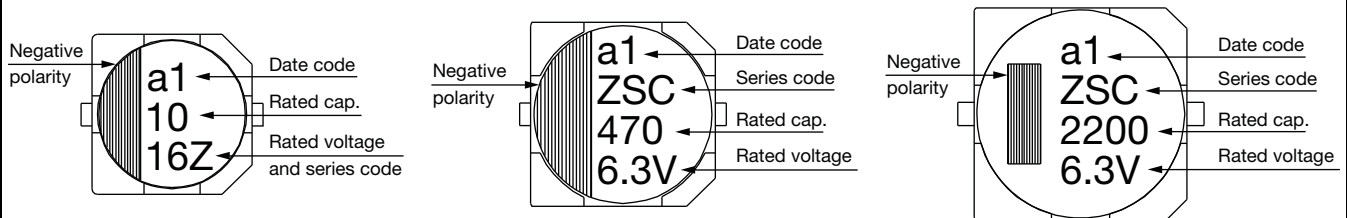



<b>SELECTION CHART, DIMENSIONS, AND PERMISSIBLE RIPPLE CURRENT (at 100 kHz / 105 °C)</b>																				
V <sub>DC</sub>		6.3 (0J)			10 (1A)			16 (1C)			25 (1E)			35 (1V)			50 (1H)			
CAP.	CODE	Ø D x L	IMP.	mA	Ø D x L	IMP.	mA	Ø D x L	IMP.	mA	Ø D x L	IMP.	mA	Ø D x L	IMP.	mA	Ø D x L	IMP.	mA	
1.0	010																4 x 5.7	2.9	60	
2.2	2R2																4 x 5.7	2.9	60	
3.3	3R3																4 x 5.7	2.9	60	
4.7	4R7													4 x 5.7	1.35	80	5 x 5.7	1.52	85	
10	100							4 x 5.7	1.35	80	4 x 5.7	1.35	80	5 x 5.7	0.80	150	6.3 x 5.7	0.88	165	
22	220	4 x 5.7	1.35	80	4 x 5.7	1.35	80	5 x 5.7	0.80	150	5 x 5.7	0.80	150	6.3 x 5.7	0.44	230	6.3 x 5.7	0.88	165	
33	330	4 x 5.7	1.35	80	5 x 5.7	0.80	150	6.3 x 5.7	0.44	230	6.3 x 5.7	0.44	230	6.3 x 5.7	0.44	230	6.3 x 7.7	0.68	185	
47	470	5 x 5.7	0.80	150	6.3 x 5.7	0.44	230	6.3 x 5.7	0.44	230	6.3 x 5.7	0.44	230	6.3 x 5.7	0.44	230	6.3 x 7.7 8 x 6.5	0.68	185	
68	680													8 x 6.5	0.36	280	8 x 10	0.34	369	
100	101	6.3 x 5.7	0.44	230	6.3 x 5.7	0.44	230	6.3 x 5.7	0.44	230	6.3 x 7.7 8 x 6.5	0.36	280	8 x 10	0.17	450	8 x 10 10 x 10	0.34 0.18	369 553	
150	151	6.3 x 5.7	0.44	230	6.3 x 5.7	0.44	230	6.3 x 7.7 8 x 6.5	0.36	280	8 x 10	0.17	450	8 x 10 10 x 7.7	0.17	450	10 x 10	0.18	553	
220	221	6.3 x 7.7	0.36	280	6.3 x 7.7 8 x 6.5	0.36	280	6.3 x 7.7	0.36	280	8 x 10 10 x 7.7	0.17	450	10 x 10	0.09	670	12.5 x 13.5	0.12	650	
330	331	8 x 6.5 8 x 10	0.36 0.17	280 450	8 x 10 10 x 7.7	0.17	450	8 x 10 10 x 7.7	0.17	450	8 x 10	0.17	450	12.5 x 13.5 10 x 10	0.070 0.09	820 670	12.5 x 13.5	0.12	650	
470	471	8 x 10 10 x 7.7	0.17	450	8 x 10 10 x 7.7	0.17	450	8 x 10 10 x 10	0.17 0.09	450 670	10 x 10	0.09	670	12.5 x 16	0.060	950	16 x 16.5	0.073	1000	
680	681	8 x 10 10 x 7.7	0.17	450	10 x 10	0.09	670	10 x 10	0.09	670	12.5 x 13.5	0.070	820	12.5 x 16	0.060	950	16 x 16.5	0.073	1000	
1000	102	8 x 10	0.17	450	10 x 10	0.09	670	12.5 x 13.5	0.070	820	12.5 x 16	0.060	950	16 x 16.5	0.054	1260	18 x 16.5	0.066	1500	
1500	152	10 x 10	0.09	670	12.5 x 13.5	0.070	820	12.5 x 16	0.060	950	16 x 16.5	0.054	1260	18 x 16.5 16 x 21.5	0.048 0.038	1500 1630	18 x 21.5	0.05	1620	
2200	222	12.5 x 13.5	0.070	820	12.5 x 16	0.060	950	16 x 16.5	0.054	1260	16 x 16.5	0.054	1260	18 x 21.5	0.038	1750				
3300	332	12.5 x 16	0.060	950	16 x 16.5	0.054	1260	16 x 16.5 16 x 21.5	0.054 0.038	1260 1630	18 x 16.5 16 x 21.5 18 x 21.5	0.048 0.038 0.038	1500 1630 1750							
4700	472	16 x 16.5	0.054	1260	16 x 16.5	0.054	1260	18 x 16.5 16 x 21.5	0.048 0.038	1500 1630										
6800	682	18 x 16.5 16 x 21.5	0.048 0.038	1500 1630	18 x 16.5 16 x 21.5	0.048 0.038	1500 1630													
8200	822	18 x 16.5 16 x 21.5	0.048 0.038	1500 1630	18 x 21.5	0.038	1750													

<b>SELECTION CHART, DIMENSIONS, AND PERMISSIBLE RIPPLE CURRENT (at 100 kHz / 105 °C)</b>										
V <sub>DC</sub>		63 (1J)			80 (1K)			100 (2A)		
CAP.	CODE	Ø D x L	IMP.	mA	Ø D x L	IMP.	mA	Ø D x L	IMP.	mA
4.7	4R7	5 x 5.7	1.90	70						
10	100	6.3 x 5.7	1.20	130						
22	220	6.3 x 7.7	0.90	150	8 x 10	1.3	130	8 x 10	1.3	130
33	330	8 x 10	0.50	280	8 x 10	1.3	130	10 x 10	0.7	200
47	470	8 x 10	0.50	280	10 x 10	0.7	200	10 x 10	0.7	200
100	101	10 x 10	0.25	450	10 x 10	0.7	200	12.5 x 13.5	0.32	450
150	151	12.5 x 13.5	0.15	700	12.5 x 13.5	0.32	450	12.5 x 16	0.26	550
220	221	12.5 x 13.5	0.15	700	12.5 x 16	0.26	550	16 x 16.5 18 x 21.5	0.17 0.15	650 950
330	331	16 x 16.5	0.082	900	16 x 16.5	0.17	650	18 x 16.5 16 x 21.5	0.15	850 900
470	471	16 x 16.5	0.082	900	16 x 21.5	0.15	900	18 x 21.5	0.15	950
680	681	18 x 16.5 16 x 21.5	0.080	1150	18 x 21.5	0.15	950			
1000	102	18 x 21.5	0.060	1250						

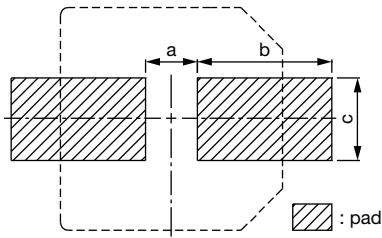
**SOLDERING**

Recommended soldering pad dimensions

<b>RECOMMENDED SOLDERING PAD DIMENSIONS</b> in millimeters			
CASE SIZE ( $\emptyset$ )	LAND SIZE		
	a	b	c
3	0.8	2.2	1.6
4	1.0	2.6	1.6
5	1.4	3.0	1.6
6.3	1.9	3.5	1.6
8 x 6.5	2.1	4.0	1.6
8	3.0	3.5	2.5
10	4.0	4.0	2.5
12.5	4.0	6.0	3.2
16	6.0	7.0	3.2
18	6.0	8.0	3.2

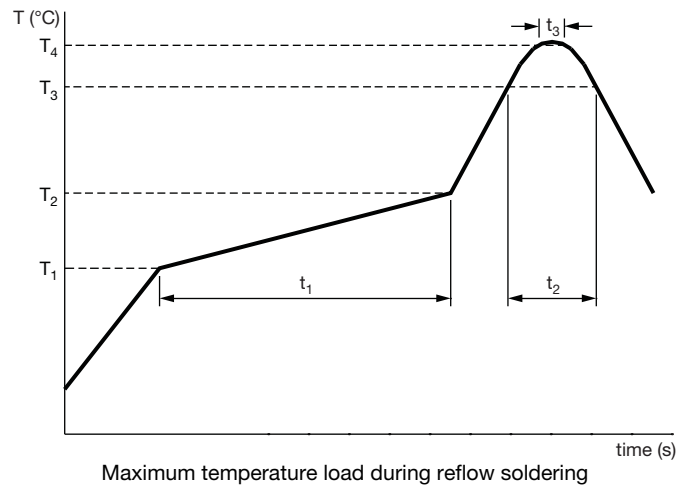
**STANDARD SOLDERING PROFILE FOR LEAD (Pb)-FREE REFLOW PROCESS**

<b>REFLOW SOLDERING CONDITIONS</b>					
Rated voltage (V)	4 to 50	4 to 50	63 and up	4 and up	
Case size ( $\emptyset$ )	4 to 6.3 x 4.5 l	3 to 6.3	3 to 6.3	8 to 18	
Preheat	Temperature ( $T_1$ to $T_2$ , °C)	150 to 180			
	Time ( $t_1$ ) (max., s)	1210	100		
Duration	Temperature ( $T_3$ , °C)	230	217	230	217
	Time ( $t_2$ ) (max., s)	30	90	60	60
Peak	Temperature ( $T_4$ , °C)	250	260		250
	Time ( $t_3$ , s)	5			
Reflow cycles	1			2 or less	

## X-ON Electronics

Largest Supplier of Electrical and Electronic Components

*Click to view similar products for [Aluminium Electrolytic Capacitors - SMD category](#):*

*Click to view products by [Vishay manufacturer](#):*

Other Similar products are found below :

[EEV-FK1E332W](#) [22927](#) [MAL214099813E3](#) [HUB1800-S](#) [34610](#) [RYK-50V101MG5TT-FL](#) [107AXZ016MQ5](#) [EMK1EM471GB0D00R](#)  
[RVT2A4R7M0605](#) [MAL214097402E3](#) [MAL224699909E3](#) [MAL224699813E3](#) [MAL215099017E3](#) [MAL215099117E3](#) [MAL215099818E3](#)  
[AEH1010471M010R](#) [AEA1010681M016R](#) [AEA1010471M025R](#) [AEA0810331M010R](#) [AEA1616102M050R](#) [AEH1010101M050R](#)  
[AEH0810470M050R](#) [AEA0810220M100R](#) [AEA0810151M035R](#) [AEA0810331M016R](#) [AEA0810470M063R](#) [AEA1213471M035R](#)  
[AEH0608220M050R](#) [AEH0608330M050R](#) [AEH0608470M025R](#) [AEH0608470M035R](#) [AEH0810101M025R](#) [AEH1012101M063R](#)  
[GSC00AC3301AARL](#) [GSC00AC3301CARL](#) [MAL215375221E3](#) [ZSC00AF2211EARL](#) [VB1E100MB054000CE0](#) [HV100M100E077ETR](#)  
[RC0J226M04005VR](#) [RC0J476M05005VR](#) [RC1A227M08010VR](#) [RC1C476M6L005VR](#) [RC1V227M10010VR](#) [35SZV10M5X5.5](#)  
[MAL214099111E3](#) [EXV107M025A9HAA](#) [50SKV1M4X5.5](#) [UCD1V100MCQ1GS](#) [UCX1H471MNQ1MS](#)