

## Low Ohmic Power Resistors, low inductance, ceramic case



## Specifications

Type		KN350-8	KN351-8	KN352-8	KN353-8	KN354-8
Styles		7718	7725	7738	9925	9938
Power rating $P_{70}$	W	4	5	7	7	9
Resistance range	$\Omega$	0R003 ... 0R051	0R004 ... 0R068	0R005 ... 0R1	0R004 ... 0R068	0R005 ... 0R1
E-Series		E24>0R01	E24>0R01	E24>0R01	E24>0R01	E24>0R01
Tolerances	%		$\pm 1, \pm 2, \pm 3, \pm 5$			
Temperature coefficient	$10^{-6} \cdot K^{-1}$		+ 200 ... + 1200 depends on value			
max. cont. work. voltage	$V_{RMS}$		$\sqrt{P_{70} \cdot R}$ for all styles			
Insulation voltage (1min.)	$V_{RMS}$		2000			
Insulation resistance	$\Omega$		$> 10^4 M$			
Derating	$^{\circ}C$		linear 70 ... 250 (0W)			
Climatic category			55/200/56			
Temperature range	$^{\circ}C$		- 55 ... 250			
Thermal resistance	$KW^{-1}$	65	50	38	35	30
Failure rate (Total, $\vartheta_o$ , max., 60% conf. lev.)	$10^{-9} \cdot h^{-1}$		appr. 10, depends on value			
Endurance ( $P_{70}$ , @70 $^{\circ}C$ , 1000h interm.)	$\left[\frac{AR}{R}\right] \%$		$\pm 3,0$ average			
Damp heat, steady state (40 $^{\circ}C$ , 93% r.h., 56d)	$\left[\frac{AR}{R}\right] \%$		$\pm 0,5$			
Climatic sequence	$\left[\frac{AR}{R}\right] \%$		$\pm 0,5$			
Terminal strength	$\left[\frac{AR}{R}\right] \%$		$\pm 0,5$			
Terminal tensile strength	N		min. 25			
Resistance to soldering heat (260 $^{\circ}C$ , 10s)	$\left[\frac{AR}{R}\right] \%$		$\pm 0,2$ typ.			
Solderability	s	2,5 Flowtime, solderglobule test, IEC 60068-2-20-T				
Marking		printed in clear				

Dimensions in mm:

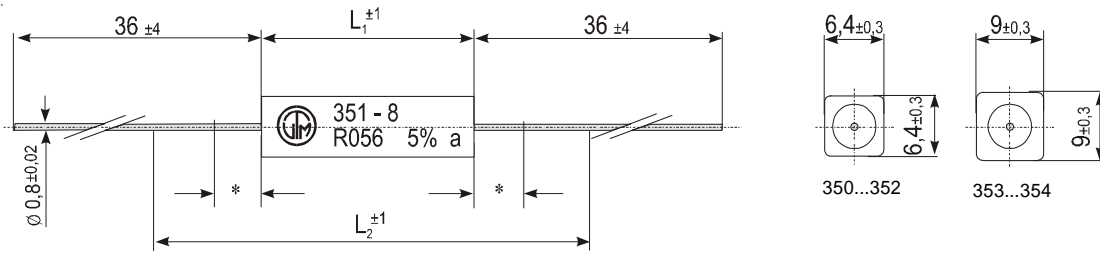

6mm. reduced solderability in this area

	KN350-8	KN351-8	KN352-8	KN353-8	KN354-8
$L_1$	18	25	38	25	38
$L_2$	40	45	60	45	60

Measuring length  $L_2$ : Resistance value is measured over the centered length  $L_2$  on terminals free of oxide and contaminations. Differing conditions require adequate corrections ( $R_{terminal} = 0,4 \text{ m}\Omega/\text{cm}$ )

Packaging:

Type	Packaging	Pieces	Pack.Code
KN350-8	bulk	200	B
	taped	1000	R
KN351-8	bulk	200	B
KN352-8	bulk	200	B
KN353-8	bulk	200	B
KN354-8	bulk	100	B

Ordering example: KN350-8                      5                      B                      0R015  
 Type                      Tolerance                      Pack.-Code                      R-Value

## Low Ohmic Power Resistors, low inductance, axial



## Specifications

Type		KN350-0	KN351-0	KN352-0
Styles		3313	3321	3332
Power rating $P_{70}$	W	1	2	3
Resistance range	$\Omega$	0R003...0R051	0R004...0R068	0R005...0R1
E-Series			E 24 > 0R01	
Tolerances	%		$\pm 1, \pm 2, \pm 3, \pm 5$	
Temperature coefficient	$10^{-6} \cdot K^{-1}$		+ 200 ... + 1200 depends on value	
max. cont. work. voltage	$V_{RMS}$		$\sqrt{P_{70} \cdot R}$ for all styles	
Insulation voltage (1min.)	$V_{RMS}$		non insulated	
Insulation resistance	$\Omega$		non insulated	
Derating	$^{\circ}C$		linear 70 ... 300 (0W)	
Climatic category			55/200/56	
Temperature range	$^{\circ}C$		- 55 ... 300	
Thermal resistance	$KW^{-1}$	200	100	70
Failure rate (Total, $\vartheta_o$ , max., 60% conf. lev.)	$10^{-9} \cdot h^{-1}$		appr. 10, depends on value	
Endurance ( $P_{70}$ , @70 $^{\circ}C$ , 1000h interm.)	$\left[\frac{\Delta R}{R}\right] \%$		$\pm 3,0$	
Damp heat, steady state (40 $^{\circ}C$ , 93% r.h., 56d)	$\left[\frac{\Delta R}{R}\right] \%$		$\pm 0,5$	
Climatic sequence	$\left[\frac{\Delta R}{R}\right] \%$		$\pm 0,5$	
Terminal strength	$\left[\frac{\Delta R}{R}\right] \%$		$\pm 0,5$	
Terminal tensile strength	N		min. 25	
Resistance to soldering heat (260 $^{\circ}C$ , 10s)	$\left[\frac{\Delta R}{R}\right] \%$		$\pm 0,2$ typ.	
Solderability	s	2,5 Flowtime, solderglobule test, IEC 60068-2-20-T		
Marking		value imprinted		

Dimensions in mm:

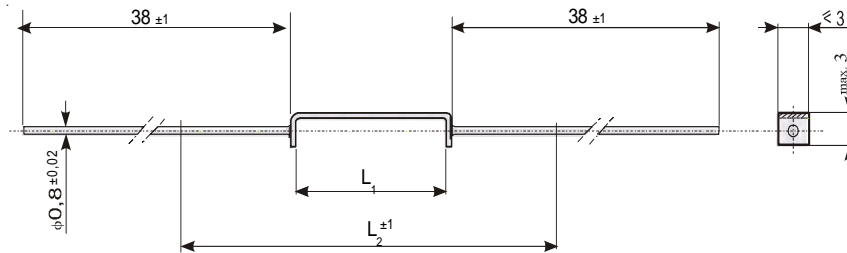

Type	$L_1$	$L_2 \pm 1$
KN350-0	12 ... 14,5	40
KN351-0	17,5 ... 21,5	45
KN352-0	29 ... 34	60

Measuring length  $L_2$ : Resistance value is measured over the centered length  $L_2$  on terminals free of oxide and contaminations. Differing conditions require adequate corrections ( $R_{\text{terminal}} = 0,4 \text{ m}\Omega/\text{cm}$ )

Packaging:

Type	Packaging	Pieces	Pack.Code
KN350-0	bulk	500	B
KN351-0	bulk	500	B
KN352-0	bulk	500	B

Ordering example:    KN351-0                    3                    B                    0R033  
 Type                    Tolerance            Pack.-Code        R-Value

## Low Ohmic Power Resistors, low inductance, radial



## Specifications

Type		KN350-009	KN351-009 KN351-010	KN352-009 KN352-010 KN352-011
Power rating $P_{70}$	W	0,5	1,0	1,5
Resistance range	$\Omega$	0R003...0R051	0R003...0R082	0R005...0R1
E-Series			E 24 $\geq$ 0R01	
Tolerances	%		$\pm 1, \pm 2, \pm 3, \pm 5$	
Temperature coefficient	$10^{-6} \cdot K^{-1}$		+ 200 ... + 1200	
max. cont. work. voltage	$V_{RMS}$		$\sqrt{P_{70} \cdot R}$ for all styles	
Insulation voltage (1min.)	$V_{RMS}$		non insulated	
Insulation resistance	$\Omega$		non insulated	
Derating, linear	$^{\circ}C$		70 ... 300 (0W)	
Climatic category			55/200/56	
Temperature range	$^{\circ}C$		- 55 ... 300	
Thermal resistance	$KW^{-1}$	200	100	70
Failure rate (Total, $\vartheta_o$ , max., 60% conf. lev.)	$10^{-9} \cdot h^{-1}$		ca. 10, depends on value	
Endurance ( $P_{70}$ , 70 $^{\circ}C$ , 1000h interm.)	$\left[\frac{AR}{R}\right]\%$		$\pm 3,0$	
Damp heat, steady state (40 $^{\circ}C$ , 93% r.h., 56d)	$\left[\frac{AR}{R}\right]\%$		$\pm 0,5$	
Climatic sequence	$\left[\frac{AR}{R}\right]\%$		$\pm 0,5$	
Terminal strength	$\left[\frac{AR}{R}\right]\%$		$\pm 0,5$	
Terminal tensile strength	N		min. 25	
Resistance to soldering heat (260 $^{\circ}C$ , 10s)	$\left[\frac{AR}{R}\right]\%$		$\pm 0,2$ typ.	
Solderability	s	2,5 Flowtime, solderglobule test, IEC 60068-2-20-T		
Marking		value imprinted		

Dimensions in mm:

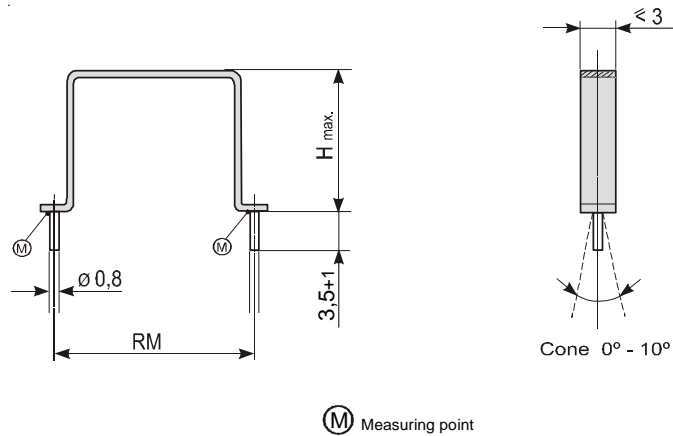

(M) Measuring point

Type	RM	Hmax.
KN350-009 KN351-009 KN352-009	10	6,5 10,5 17,0
KN351-010 KN352-010	15	8 14,5
KN352-011	20	12

**Construction:** The resistive elements consist of a flat metal-band. Spot welded Cu-terminals ensure high stability of contacts. Thus, this construction results in a non inductive resistor of both high stability and overload capacity.

**Packaging:**

Type	Packaging	Pieces	Pack.Code
KN350-009	bulk	1000	B
KN351-009 KN351-010	bulk	1000	B
KN352-009 KN352-010 KN352-011	bulk	500	B

Ordering example:    KN350-009            5            B            0R015  
                                  Type            Tolerance    Pack.-Code    R-Value

Revision 200807

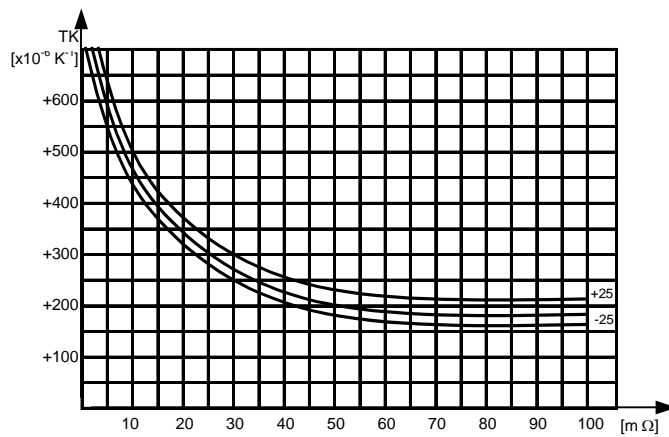

**Diagram:** Temperature coefficient of metal-band resistors series KN (350-354)

### Pulse capability of resistors:

General information on pulse capability very often need additional explanations and do not always comply with a given application.

Please contact factory or sales office for your special requirements. For dealing with your application we need the following information:

- Pulse shape and repetition rate
- max. peak power
- Pulseduration or time constant
- max. peak voltage
- Resistance value

If already selected:

- Type or series or technology
- or preferred style

## General:

VITROHM offers a range of low-ohm resistors for current sensing applications, resistance ranges typically from 1 milliohm to 100 milliohms.

These devices are of non-wound construction and made from flat resistive alloy wire.

The resistor's specification depends on the material and the chosen dimensions, namely specific-resistance, thermal conductivity and temperature coefficient are of importance.

### 1. Standard, leaded types, KN-family Types KN 350 ... KN 354

The „KN-resistors“ are available in standardized sizes with choices of open-frame and ceramic cased types. Copper leads are welded to the resistive element for board assembly.

Attention should be given to the following:

- resistance value

The value is specified over a given „measuring length“. Between the two measuring points lies the element plus some copper-wire for contact purposes.

If the actual used total length of the resistor in the application differs from this specified length, the influence of the copper wire of 0.4 mΩ per centimeter must be considered.

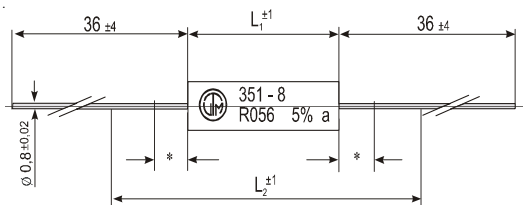

- temperature coefficient

Typically the temperature coefficient of the resistive element ranges around 150 ppm/°C (ask factory for details). However, the copper wire is part of the effective resistance and influences the TC between the contacts.

The lower the resistance value, the more influence of the copper leads, the higher the TC!

If the TC is of concern in a given application, a vertical style of the KN-family should be used (type 35X-009). In this case the influence of the copper wire is almost eliminated.

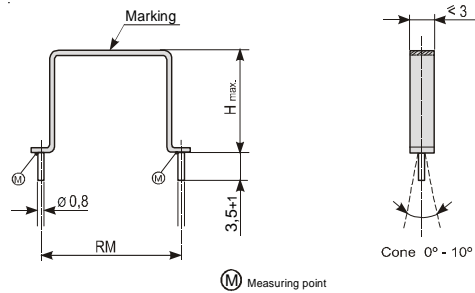

- power and current rating

The „KN-resistors“ are standard products with a fixed given power rating ( $P_{70}$ ). Nevertheless, current rating can be of concern, especially if overload or pulse conditions can occur.

The current limit is defined by the current density, and 100 A per mm<sup>2</sup> are considered absolute maximum in power electronics. With a 0.8 mm diameter copper wire, the current limit is 50 A.

With respect to reliability, the welding junction between copper and resistive alloy should not carry more than 20 A continuously.

The 50 A limit may not be exceeded even under pulse conditions.

### 2. Semi-customized types, LPS-family Types LPS 355 ... LPS 359

VITROHM provides tools to produce U-shaped low-ohm resistors for direct board mounting.

The solder-tags (1 or 2 per side) are of given dimensions, the size of the final unit is designed in accordance with the applicational requirements.

If the demand for a shunt-resistor justifies a customized solution, the LPS-family offers a variety of possibilities.





## Low Ohmic Power Resistors, low inductance, radial

### Specifications

Type		KN353-009	KN353-010	KN353-011
Nominal Power rating $P_{70}$	W	3		
Resistance range	$\Omega$	0R005,0R01,0R015,0R02,0R022,0R03,0R033 0R039,0R047,0R051,0R06,0R068,0R082,0R1 (other values under request)		
E-series		E24 >0R01		
Tolerance	%	$\pm 1$ , $\pm 2$ , $\pm 3$ , $\pm 5$		
Temperature coefficient	$10^{-6} \cdot K^{-1}$	+ 200 ... + 1200 Depends on value		
Max. cont. working voltage	$V_{RMS}$	$\sqrt{P_{70} \cdot R}$ for all styles		
Insulation voltage (1min.)	$V_{RMS}$	non insulated		
Insulation resistance	$\Omega$	non insulated		
Derating linear	$^{\circ}C$	70 ... 300 (0W)		
Climatic category		55/200/56		
Temperature range	$^{\circ}C$	-55...300		
Thermal resistance	$KW^{-1}$	60		
Failure Rate (Total $\vartheta_0$ max, 60% conf. lev.)	$10^{-9} \cdot h^{-1}$	Appr. 10, depends on value		
Endurance ( $P_{70}$ , @70 $^{\circ}C$ , 1000h, interm.)	$[\Delta R/R]$ %	$\pm 3,0$		
Damp heat, steady state (40 $^{\circ}C$ , 93% r.h., 56d)	$[\Delta R/R]$ %	$\pm 0,5$		
Climatic sequence	$[\Delta R/R]$ %	$\pm 0,5$		
Terminal strength	$[\Delta R/R]$ %	$\pm 0,5$		
Terminal tensile strength	N	min. 25		
Resistance to soldering heat (260 $^{\circ}C$ , 10s)	$[\Delta R/R]$ %	0,2% typ.		
Solderability	S	2,5 Flowtime, solderglobe test, IEC 60068-2-20-T		
Marking		Value imprinted		

Dimensions in mm:

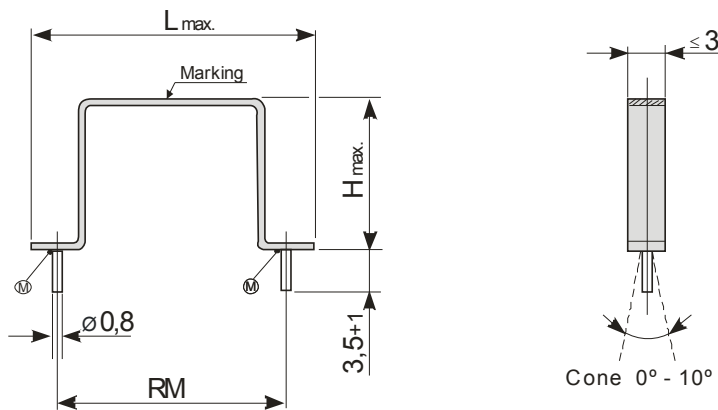

Ⓜ measuring point

Type	RM	H max.	L max.
KN353-009	10	20	16
KN353-010	15	18	21
KN353-011	20	15	26

Construction: The resistive elements consist of a flat metal-band. Spot welded Cu-terminals ensure high stability of contacts. Thus, this construction results in a non inductive resistor of both high stability and overload capacity.

Packaging:

Type	Packaging	Pieces	Pack.Code
KN353-009 KN353-010 KN353-011	Bulk	500	B

Ordering example: KN353-010 5 B 0R015  
 Type Tolerance Pack.-Code R- value

Revision 201106

## X-ON Electronics

Largest Supplier of Electrical and Electronic Components

*Click to view similar products for [Thin Film Resistors - Through Hole](#) category:*

*Click to view products by [Vishay](#) manufacturer:*

Other Similar products are found below :

[RESISTOR-0125-A](#) [MBA02040C3249FC100](#) [MRS16000C2200FCT00](#) [MRS16000C1501FCT00](#) [MRS16000C6803FCT00](#)  
[MRS16000C2703FCT00](#) [MRS16000C4703FCT00](#) [MBA02040C1209FCT00](#) [MBA02040C2701FCT00](#) [MBA02040C3301FCT00](#)  
[MBA02040C3901FCT00](#) [MBA02040C5600FCT00](#) [MBA02040C6809FC100](#) [MBB02070D9312BCT00](#) [MBA02040C1008FCT00](#)  
[MBA02040C1200FCT00](#) [MBA02040C2202FCT00](#) [MBA02040C4754FRP00](#) [MBA02040C6041FRP00](#) [MBB02070C1821FRP00](#)  
[MBB0207IC1001FCT00](#) [MFP1-10RJI](#) [MFP2-100KJI](#) [MFR4-1K0FI](#) [MFR4-220RFI](#) [MFR4-33RFI](#) [BPC5563K](#) [BPR5473J](#) [W21-1R2JI](#) [W31-](#)  
[R056JA1](#) [WR404140A6803J4100](#) [MFR3-47KFC](#) [MFR4-1R0FI](#) [MFR4-390RFI](#) [MRS25000C2373FC100](#) [CF18JT47K0](#)  
[MRS25000C1051FC100](#) [MFR5-15RFI](#) [MBB0207VD1004BC100](#) [BPC10203J](#) [RSF12JT150R](#) [RC14JT39K0](#) [MBA02040C6980FC100](#)  
[MRS25000C2002FC100](#) [MRS25000C8200FC100](#) [MBA02040C1878FC100](#) [MBE04140C1200FC100](#) [MBA02040C1600FC100](#)  
[MBA02040C7508FC100](#) [TNP10SC20R0FE](#)