

5.5A/12V/1MHz Boost Converter

General Description

The VP3187 is designed to provide fast response and high efficiency (Power Saving Mode) with built-in 100mΩ N-channel MOSFET switch. It operates with external compensated, fixed 1MHz oscillation frequency and current mode modulation to provide the flexibility of various kinds of applications. The VP3187 sinks current up to 5.5A peak and is capable of soft-start time programming to avoid in-rush current. With 2.7V to 5.5V input voltage, VP3187 can boost the output voltage up to 12V. This makes it excellent to be applied in consumer electronics especially Li-ion battery powered speakers.

The VP3187 also features many protection schemes such as input under-voltage lockout, over current protection, input over/under voltage protection and over-temperature protection.

VP3187 is available in small SO-8P with exposed pad.

Features

- Wide Input Voltage from 2.7V to 5.5V
- 600mV Reference Voltage with $\pm 2\%$ Accuracy
- Power Saving Mode
- 5.5A Peak Cycle-by-Cycle Current Limit
- 18V/100mΩ Internal MOSFET Switch
- 1MHz PWM Frequency
- Internal Soft-Start
- Over Temperature Protection
- Adjustable Over Current Protection
- Input Under-Voltage Lockout
- SO-8P Green Package with RoHS Compliant

Applications

- Portable Speaker
- LCD Monitor/LCD TV
- Battery Powered Device
- Set-Top Box
- DSL and Cable Modem

Typical Application

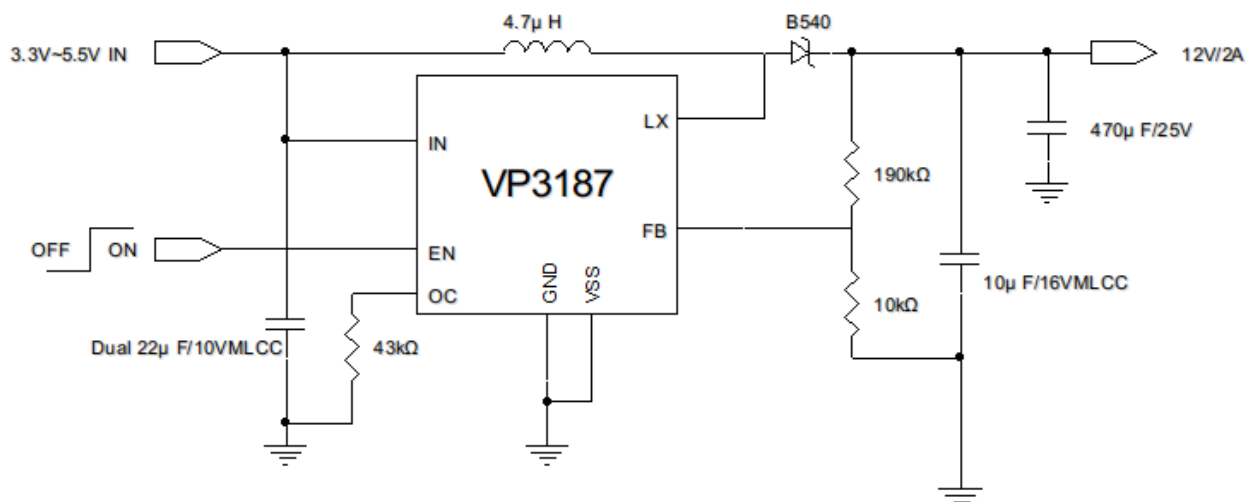

Functional Block Diagram

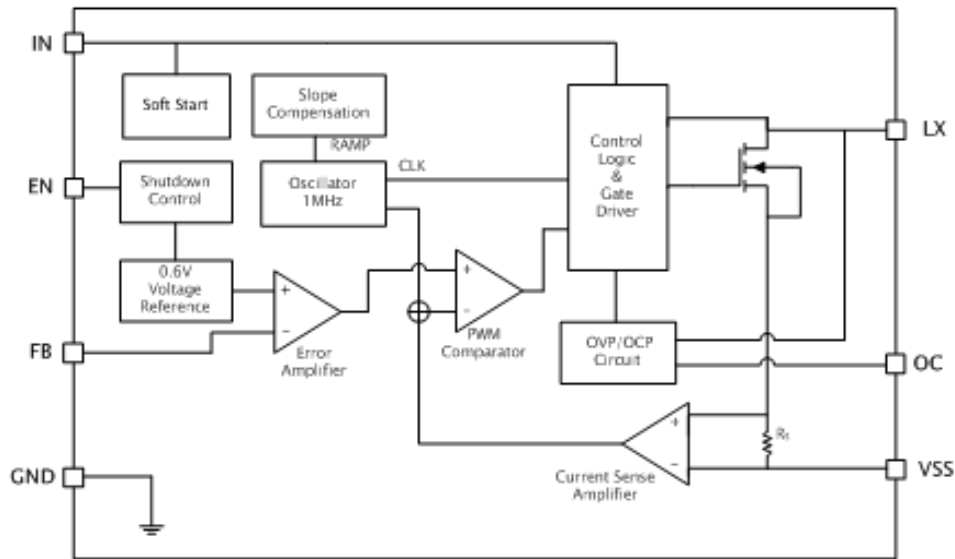

Pin Assignments And Descriptions

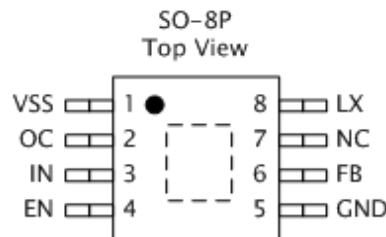

Pin No.	Pin	I/O/P	Function Description
1	VSS	P	Power Ground.
2	OC	I	Current Limit Setting. Connect a resistor from OC to GND to set the peak switching current. Leave it floating for internal current limit.
3	IN	I	Supply Input. Drive IN with a 2.7V to 5.5V power source to activate the converter.
4	EN	I	Chip Enable. Pull EN high to enable the converter, pull it low to turn it off. Pull up with a 100kΩ resistor to start it up automatically.
5	GND	P	Analog Ground. Connect to exposed pad.
6	FB	I	Feedback Input. Connect the external resistor divider network from output to this pin to sense output voltage. The FB pin voltage is regulated to internal 1.26V reference voltage.
7	NC	-	No Internal Connection.
8	LX	O	Switch Output. Connect this pin to the inductor and the Schottky diode. To reduce EMI, minimize the PCB trace path between this pin and the input bypass capacitor.

Absolutely Maximum Ratings

Over operating free-air temperature range, unless otherwise specified (* 1)

Symbol	Parameter	Limit	Unit
$V_{IN}(IN, EN, FB)$	Supply voltage range	-0.3 to 6	V
V_{LX}	Switch voltage range	-0.3 to 18	V
T_J	Operating junction temperature range	-40 to 150	°C
T_{STG}	Storage temperature range	-65 to 150	°C
Electrostatic discharge	Human body model	2	kV
Electrostatic discharge	Machine model	200	V
θ_{JC}	Thermal resistance (Junction to Case)	15	°C/W
θ_{JA}	Thermal resistance (Junction to Air)	75	°C/W

(*1): Stress beyond those listed at "absolute maximum rating" table may cause permanent damage to the device. These are stress rating ONLY. For functional operation are strongly recommend follow up "recommended operation conditions" table.

Recommended Operating Conditions

Symbol	Parameter	Specification		Unit
		Min	Max	
$V_{IN}(IN, EN, FB)$	Supply voltage	2.7	5.5	V
V_{LX}	Switch voltage range	$V_{IN}+0.3$	12	V
T_A	Operating free-air temperature range	-40	85	°C
T_J	Operating Junction range	-40	125	°C

Electrical Characteristics

$T_A = 25^\circ\text{C}$, $V_{IN} = V_{EN} = 5\text{V}$, unless otherwise noted

Symbol	Parameter	Test Condition	Specification			Unit
			Min	Typ	Max	
I_{SD}	Shutdown supply current	$V_{EN}=0\text{V}$		1	3	μA
I_Q	Quiescent current	$V_{FB}=0.7\text{V}$, Non Switching		0.4		mA
V_{UVLO}	Under voltage lockout	V_{IN} Rising		2.4		V
$V_{UVLOHYS}$	UVLO Hysteresis			200		mV
V_{FB}	Feedback voltage	$V_{EN}=2\text{V}$	0.588	0.6	0.612	V
I_{FB}	Feedback bias current	$V_{FB}=0.1\text{V}$			0.1	μA
$R_{DS(ON)}$	Internal switch $R_{DS(ON)}$ (*1)	$I_{LX}=1\text{A}$		100		$\text{m}\Omega$
	Current limit	$V_{IN}=3.2\text{V}$, Duty Cycle=70%		5.5		A
$I_{LX(LEAKAGE)}$	Switch Leakage Current	$V_{LX}=12\text{V}$, $V_{EN}=0\text{V}$			2	μA
I_{OC}	Current Limit Adjustable Range	$I_{OC}=20\text{k}\Omega\sim 43\text{k}\Omega$	2.1		4.9	A
f_{OSC}	Oscillation frequency			1		MHz
D_{MAX}	Maximum duty cycle	$V_{FB}=0\text{V}$		90		$\%$
	Chip enable threshold	V_{EN} rising		1		V
	Chip shutdown threshold	V_{EN} falling		0.4		V
	Thermal shutdown threshold(*1)			150		$^\circ\text{C}$

(*1) Design Center Value

Functional Descriptions

The VP3187 is a highly efficient boost DC/DC converter that employ a current-mode, fixed frequency pulse-width modulation (PWM) architecture. It operates at constant switching frequency under medium to high load current conditions. With built-in 100mΩ N-Channel MOSFET to provide a high efficiency regulator with fast response to step load transient. The device is capable of delivering output 2A current at 12V from an input voltage range of 2.7V to 5.5V.

At the case of light load, the regulator operates in a pulse-skipping mode in order to improve light-load efficiency.

The VP3187 incorporates external compensated, fixed 1MHz frequency, current mode pulse-width modulation circuit enabling the flexibility for loop dynamic and possibility for smallest external component size. The VP3187 reduces its current consumption to less than 1μA during shutdown mode.

Other features include input under-voltage lockout, Over-current protection, under voltage protection and over-temperature protection. The VP3187 is available in space-saving SO-8P package.

Input Voltage and Power-On Reset

The IN pin receives a well-regulated supply voltage of 2.7V ~ 5.5V to provide bias current for the control circuit. The V_{IN} is continuously monitored for power on reset (POR) to insure the supply voltage is high enough for normal operation. The POR threshold level is 2.4V at the rising edge of V_{IN} with 200mV hysteresis.

A minimum 1μF ceramic capacitor physically near the IN pin is required for locally bypassing the supply input.

Chip Enable

Pulling the EN pin lower than 0.4V disables the VP3187 and reduces its quiescent current to less than 1μA. The internal reference, error amplifier and biasing circuitry and power MOSFET are turned off. The output voltage is connected to V_{IN} by the external inductor and diode.

Pulling the EN pin higher than 1V enables the VP3187 and initiates its soft start cycle.

Programming Output Voltage

A voltage divider taped to FB pin programs the output voltage as:

$$V_{OUT} = 0.6V \times \frac{R_1 + R_2}{R_1}$$

In real application, keep R1 around 10kΩ and select R2 according to the required output voltage. Place the voltage divider near the FB pin and keep the connecting trace away from the noisy nodes like LX.

Adjusting Peak Switch Current

To adjust the peak switching current is easy by connecting a resistor R_{OCP} from OC pin to GND. The peak switch current I_{OCP} is given as:

$$I_{OCP} = \frac{105k\Omega}{R_{OCP}} - 0.1A$$

Thermal Shutdown

The VP3187 features integrated thermal overload protection. Both devices are automatically disabled when their junction temperatures exceed 150°C, and automatically resume output when the die temperature decreases by 40°C.

Functional Descriptions (cont.)

PWM Operation

The VP3187 adopts constant frequency, slope compensated current mode control with light-load pulse skipping scheme. The internal MOSFET is turned on at the beginning of each clock, allowing the inductor current to ramp up linearly. The MOSFET remains on until either the current-limit is tripped or the PWM comparator turns off the switch for regulating output voltage. The inductor current is sensed, slope compensated and compared with the error amplifier output COMP to determine the adequate duty cycle.

When the MOSFET is turned off, the catch diode is forward biased and boosts the energy stored in inductor to output voltage.

The FB pin senses output feedback voltage from an external resistive divider. When the load current increases, it causes a slight decrease in the feedback voltage relative to the 0.6V reference, which in turn, causes the error amplifier output voltage to increase until the inductor current matches the new load current.

Current Limit and Under-Voltage Protection

The inductor current is limited to 5.5A internally. Once the over-current lasting more than 50 μ s, the VP3187 turns off MOSFET regardless the voltage loop command. When this happens, the output voltage will be lower than its target level. The UVP is latch-off type and can be reset only by power-on-reset or toggling the EN pin.

The output current capability of VP3187 is a function of current limit, input/output voltage, operation frequency. The duty cycle can be expressed according to voltage balance of the inductor as:

$$D \times (V_{IN} - I_{IN} \times (R_{DS(ON)} + DCR)) = (1 - D) \times (V_{OUT} - V_{IN} - V_D - I_{IN} \times DCR)$$

$$D = \frac{V_{OUT} + V_D - V_{IN} + I_{IN} \times DCR}{V_{OUT} + V_D - I_{IN} \times R_{DS(ON)}}$$

$$D = \frac{V_{OUT} + V_D - V_{IN} + I_{IN} \times DCR}{V_{OUT} + V_D - I_{IN} \times R_{DS(ON)}}$$

where I_{IN} the maximum input current, $R_{DS(ON)}$ is the on-resistance of the integrated MOSFET, DCR is the DC resistance of the inductor, and V_D is the forward biased voltage of the catch diode at 3A. The I_{IN} is specified as 75% of the current limit level to compensate stray factors such as temperature, switching loss ...etc.

The inductor ripple current is calculated as:

$$\begin{aligned} \Delta I &= \frac{D \times (V_{IN} - I_{IN} \times (R_{DS(ON)} + DCR))}{f_{SW} \times L} \\ &= \frac{D \times (V_{IN} - 0.3 - 1.5 \times DCR)}{f_{SW} \times L} \end{aligned}$$

where f_{SW} is the switching frequency, L is the inductance at 3A.

The maximum output current can be calculated according charge balance of output capacitor as:

$$\begin{aligned} I_{OUT(MAX)} &= (1 - D) \times (I_{IN} - 0.5 \times \Delta I) \\ &= (1 - D) \times (3 - 0.5 \times \Delta I) \end{aligned}$$

Shutdown Control

Pull EN pin low to disable the IC and reduce the supply current to just 1 μ A. As with all asynchronous boost DC/DC converters, the external Schottky diode provides a DC path from the input to the output in shutdown. As a result, the output drops to one diode voltage drop below the input in shutdown.

Application Information

Component Selection

External component selection begins with inductor value selection based on the considerations of the output voltage, output current, and the maximum/minimum input voltages. Catch diode and input/output capacitors can be selected according to the inductor value L.

Selection of Input and Output Capacitor

The VP3187 is designed to work with low-ESR ceramic input/output capacitors. Select the output capacitor value according to the required output ripple voltage as:

$$C_{OUT} > \frac{0.5 \times L \times \Delta I_{LX}^2}{\Delta V_{OUT} \times V_{OUT}}$$

where ΔV_{OUT} is the peak-to-peak output ripple voltage.

Selecting Schottky Diode

The catch diode should be capable of handling the output voltage and the peak switch current. Make sure that the diode peak current rating is at least $I_{LX(PK)}$ and that its breakdown voltage exceeds V_{OUT} . Schottky diodes are recommended due to its low forward voltage and low reverse recovery current.

The capability for handling power dissipation should be considered. The power dissipation at the catch diode can be approximated as:

$$P_D = I_{OUT} \times V_D$$

where I_{OUT} is the rated output current, V_D is the forward voltage of the catch diode.

Inductor Selection

Inductor selection should consider the inductor

value, rated current, DCR, size, core material, and cost. The inductor value is selected based on the consideration of inductor ripple current. Here we define inductor current ratio LIR as the ratio of ripple current to maximum averaged current.

$$LIR = \frac{\Delta I_{LX}}{I_{LX(MAX)}} = \frac{\Delta I_{LX}}{I_{IN(MAX)}}$$

where ΔI_{LX} is the inductor ripple current, $I_{LX(MAX)}$ is the maximum averaged inductor current and $I_{IN(MAX)}$ is the maximum averaged input current.

LIR = 0.3 ~ 0.5 gives the best trade-off between inductor size and power conversion efficiency.

To calculate the LIR, the following equation gives a good approximation for calculation duty cycle at rated output current.

$$D = \frac{V_{OUT} + V_D + 0.3 - V_{IN}}{V_{OUT} + V_D}$$

where V_{OUT} is the output voltage, V_{IN} is the input voltage, V_D is the forward voltage of catch diode and 0.3V is constant to compensate the IR drop along inductor and MOSFET.

The maximum averaged input current (aka. inductor current) can be calculated according charge balance of output capacitor as:

$$I_{IN(MAX)} = \frac{I_{OUT}}{1 - D}$$

where $I_{IN(MAX)}$ is the maximum averaged input current, I_{OUT} is the rated output current.

The inductor ripple current can be calculated as:

$$\Delta I_{LX} = \frac{D \times (V_{IN} - 0.3)}{LIR \times f_{SW} \times I_{IN(MAX)}}$$

where f_{SW} is the switching frequency, L is the inductance at $I_{IN(MAX)}$.

Hence the required inductor value can be calculated as:

Application Information (cont.)

$$L = \frac{D \times (V_{IN} - 0.3)}{LIR \times f_{SW} \times I_{IN(MAX)}}$$

Maximum current ratings of the inductor are generally specified in two methods: permissible DC current and saturation current. Permissible DC current is the allowable DC current that causes 40°C temperature raise. The saturation current is the allowable current that causes 10% inductance loss. Make sure that the inductor will not saturate over the operation conditions including temperature range, input voltage range, and maximum output current. If possible, choose an inductor with rated current higher than 5.5A so that it will not saturate even under current limit condition.

The size requirements refer to the area and height requirement for a particular design. For better efficiency, choose a low DC resistance inductor. DCR is usually inversely proportional to size.

Different core materials and shapes will change the size/current and price/current relationship of an inductor. Toroid or shielded pot cores in ferrite or permalloy materials are small and don't radiate much energy, but generally cost more than powdered iron core inductors with similar electrical characteristics. The choice of which style inductor to use often depends on the price vs. size requirements and any radiated field/EMI requirements.

Application Circuit

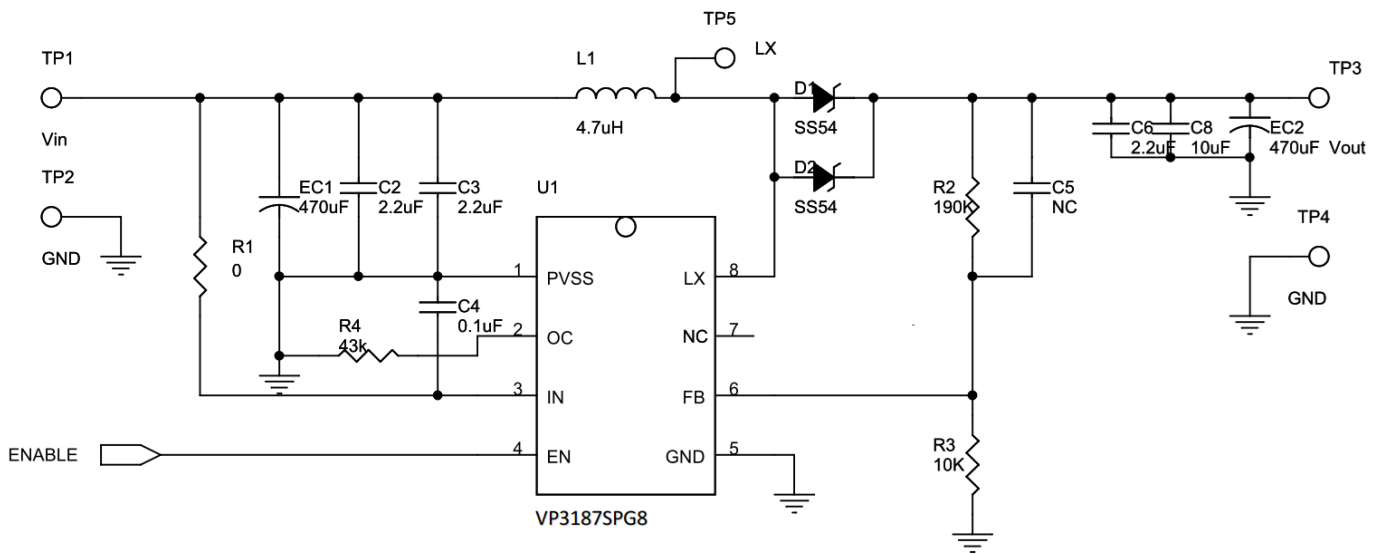

Figure 1. VP3187 Reference Application Circuit

Typical Characteristics

T_A = 25°C, unless otherwise noted

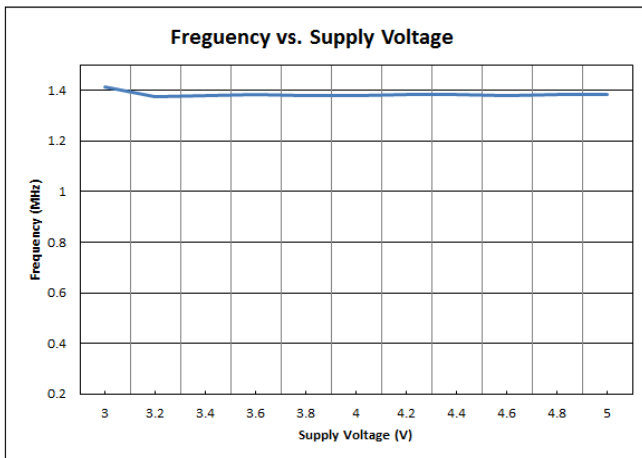

Figure 2. Frequency vs. Supply Voltage

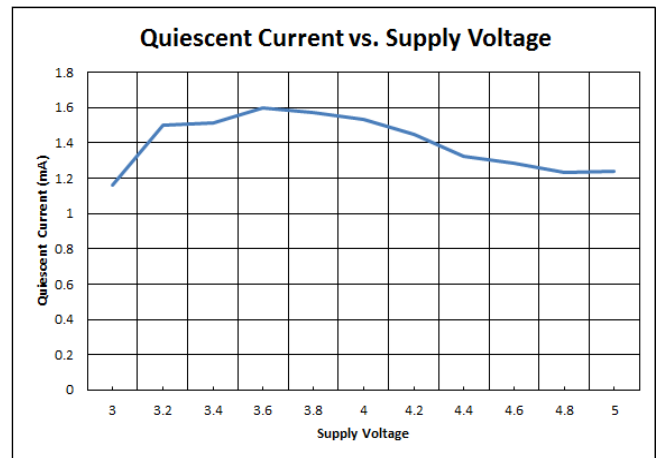

Figure 3. Quiescent Current vs. Supply Voltage

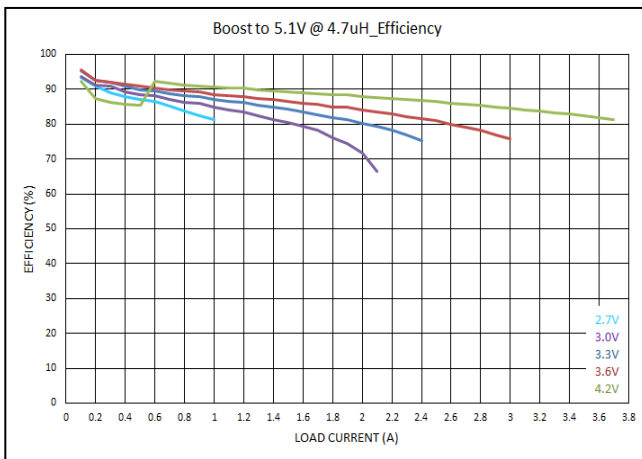

Figure 4. Boost to 5.1V Efficiency vs. Current

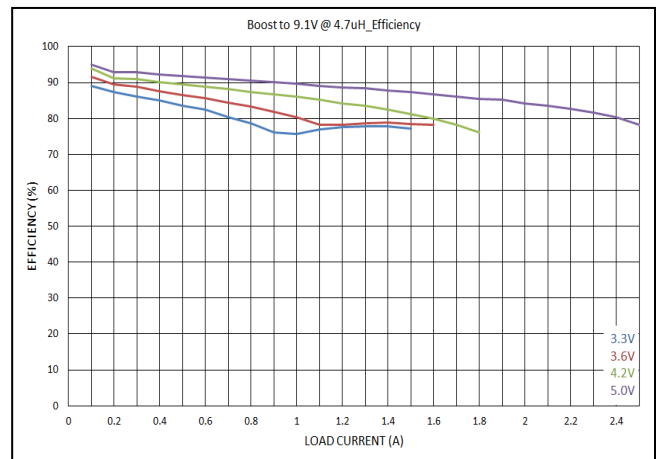

Figure 5. Boost to 9.1V Efficiency vs. Current

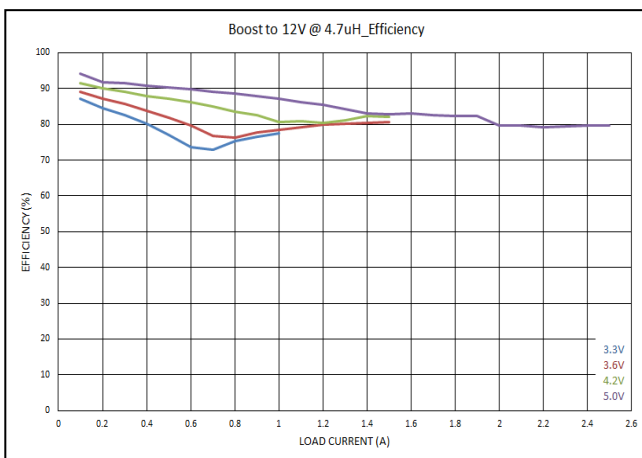
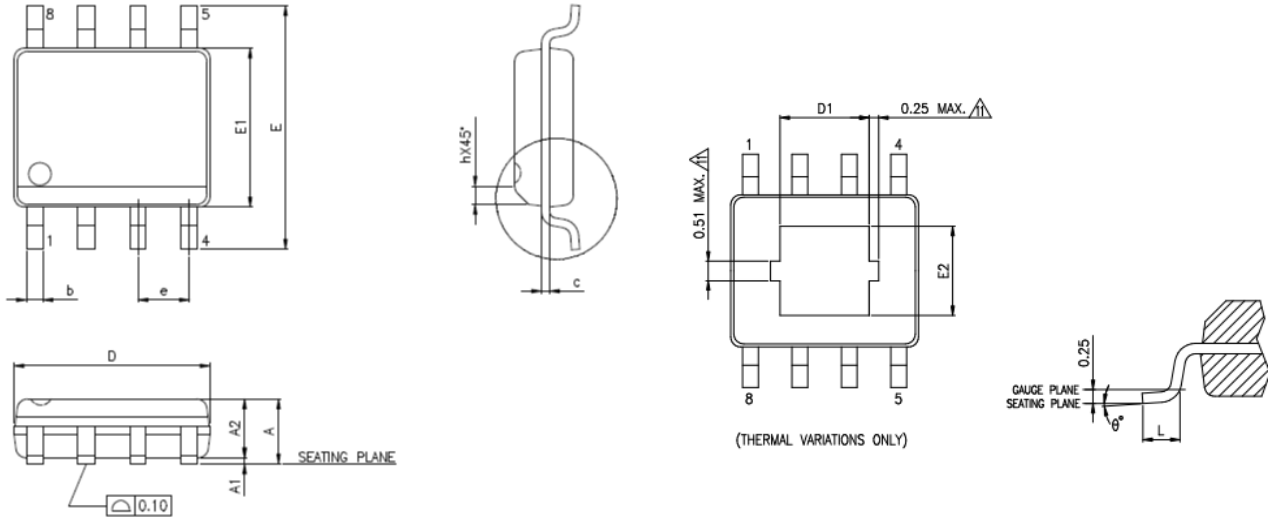

Figure 6. Boost to 12V Efficiency vs. Current

Package Information

SO-8P



Symbols	Standard		Thermal	
	Min.	Max.	Min.	Max.
A	-	1.75	-	1.70
A1	0.10	0.25	0.00	0.15
A2	1.25	-	1.25	-
b	0.31	0.51	0.31	0.51
c	0.10	0.25	0.10	0.25
D	4.90 BSC		4.90 BSC	
E	6.00 BSC		6.00 BSC	
E1	3.90 BSC		3.90 BSC	
e	1.27 BSC		1.27 BSC	
L	0.40	1.27	0.40	1.27
h	0.25	0.50	0.25	0.50
θ°	0	8	0	8

Thermal Enhanced Dimensions

Pad Size	E2		D1	
	Min.	Max.	Min.	Max.
90x90E	1.94	2.29	1.94	2.29
95x13E	2.05	2.41	2.81	3.30

Notes:

- Package Outline Unit Description:
 BSC: Basic. Represents theoretical exact dimension or dimension target.
 MIN: Minimum dimension specified.
 MAX: Maximum dimension specified.
 REF: Reference. Represents dimension for reference use only. This value is not a device specification.
 TYP: Typical. Provided as a general value. This value is not a device specification.
- Dimensions in Millimeters.
- JEDEC Outline : MS-012 AA Rev. F (Standard), MS-012 BA Rev. F (Thermal)
- Dimensions "D" does not include mold flash, protrusions or gate burrs. Mold flash, protrusions and gate burrs shall not exceed 0.51mm per side.
- Dimensions "E1" does not include inter-lead flash, or protrusions. Inter-lead flash and protrusions shall not exceed 0.25mm per side.

Ordering Information

VP3187 □ □ □

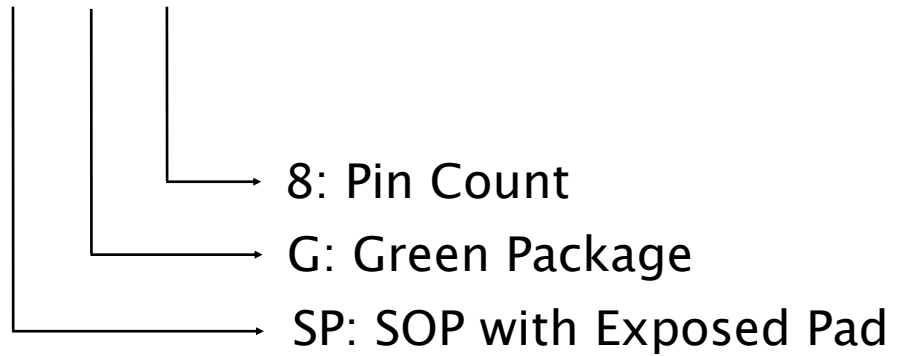

Part No.	Q`ty/Reel
VP3187SPG8	2,500

Contact Information

Viva Electronics Incorporated

10F-1, No. 32, Gaotie 2nd Rd., Zhubei City, Hsinchu County, Taiwan, R.O.C.

Tel: 886-3-6579508

Fax: 886-3-6579509

WWW: <http://www.viva-elec.com.tw>

Sales: sales@viva-elec.com.tw

FAE Support: fae@viva-elec.com.tw

X-ON Electronics

Largest Supplier of Electrical and Electronic Components

Click to view similar products for [Switching Controllers](#) category:

Click to view products by [VIVA](#) manufacturer:

Other Similar products are found below :

[AP3844CMTR-E1](#) [NCP1218AD65R2G](#) [NCP1234AD100R2G](#) [NCP1244BD065R2G](#) [NCP1336ADR2G](#) [NCP6153MNTWG](#)
[NCP81005MNTWG](#) [NCP81101BMNTXG](#) [NCP81205MNTXG](#) [SJ6522AG](#) [SJE6600](#) [AZ7500BMTR-E1](#) [IR35215MTRPBF](#) [SG3845DM](#)
[NCP4202MNR2G](#) [NCP4204MNTXG](#) [NCP6132AMNR2G](#) [NCP81102MNTXG](#) [NCP81141MNTXG](#) [NCP81203MNTXG](#) [NCP81206MNTXG](#)
[NX2155HCUPTR](#) [UBA2051C](#) [IR35201MTRPBF](#) [FSL4110LRLX](#) [NCP1015ST65T3G](#) [NCP1240AD065R2G](#) [NCP1240FD065R2G](#)
[NCP1336BDR2G](#) [NCP1361BABAYSNT1G](#) [NCP1230P100G](#) [NX2124CSTR](#) [SG2845M](#) [NCP1366BABAYDR2G](#) [NCP81101MNTXG](#)
[TEA19362T/1J](#) [NCP81174NMNTXG](#) [NCP4308DMTTWG](#) [NCP4308DMNTWG](#) [NCP4308AMTTWG](#) [NCP1366AABAYDR2G](#)
[NCP1256ASN65T1G](#) [NCP1251FSN65T1G](#) [NCP1246BLD065R2G](#) [MB39A136PFT-G-BND-ERE1](#) [NCP1256BSN100T1G](#) [LV5768V-A-](#)
[TLM-E](#) [NCP1365AABCYDR2G](#) [IR35204MTRPBF](#) [MCP1633T-E/MG](#)