

## High-Efficiency Boost DC/DC Converter

### General Description

The VP3379 is a versatile converter designed for the use in boost topology which needs no external MOSFET. Besides cycle-by-cycle current limiting, current mode control scheme also makes it wide bandwidth and good transient response. The peak current limit can be programmed simply with an external resistor.

The switching frequency can be set in any value between 100kHz and 1MHz with a resistor or any external clock source. The VP3379 can be operated at higher switching frequency to save the solution board size. While entering shutdown mode, the VP3379 only sinks 10 $\mu$ A and it allows power supply sequencing. It has built-in protection circuits such as thermal shutdown, under-voltage lockout, short circuit protection, and overvoltage protection. Internal soft-start circuitry reduces the inrush current at start-up.

VP3379 is available in small TSSOP-16 green package with exposed pad.

### Features

- Start-Up Voltage from 3V
- Input Voltage from 6V to 25V
- 26V Maximum Output Voltage
- Reference Voltage with  $\pm 1.5\%$  Accuracy
- Adjustable 100kHz~1MHz Clock Frequency
- 10 $\mu$ A Shutdown Current
- Current Mode Operation
- Integrated 30V/15m $\Omega$  MOSFET Switch
- External RC Compensation
- Internal Soft-Start
- High Efficiency at Light Loads
- Peak Current Limit and Over Temperature Protection
- Adjustable Input UVLO Threshold Voltage
- TSSOP-16 Exposed Pad Green Package with RoHS Compliant

### Applications

- Portable Speakers
- Offline Power Supply
- Battery Powered Device

### Typical Application

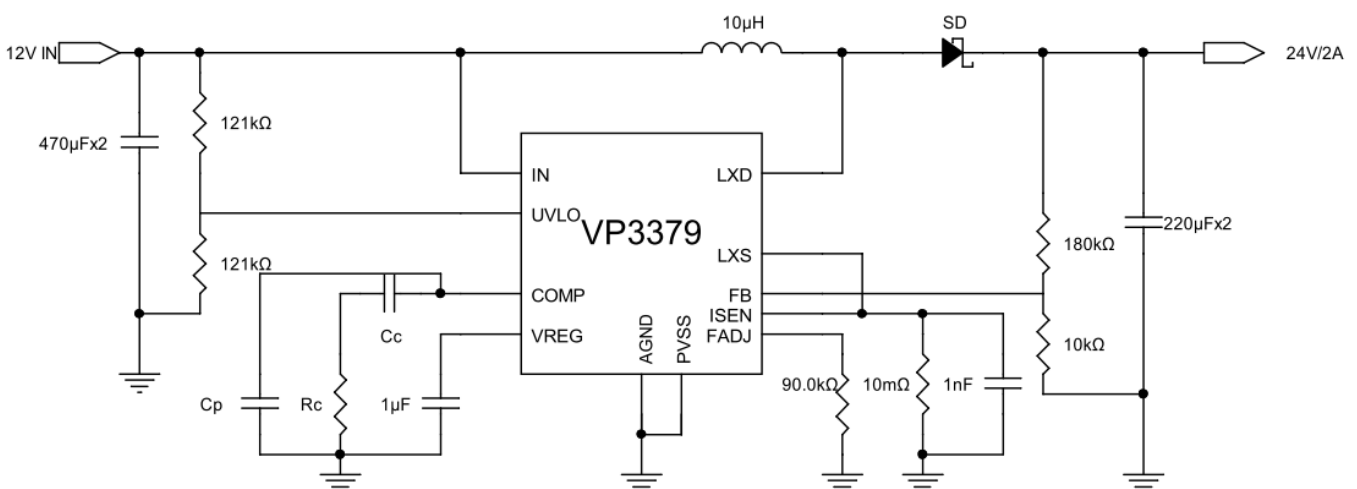

## Functional Block Diagram

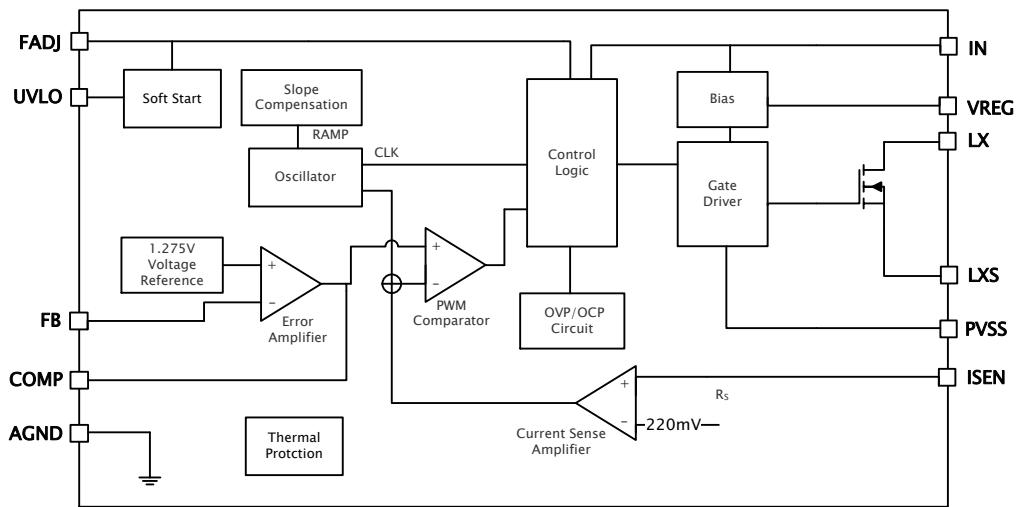

## Pin Assignments And Descriptions

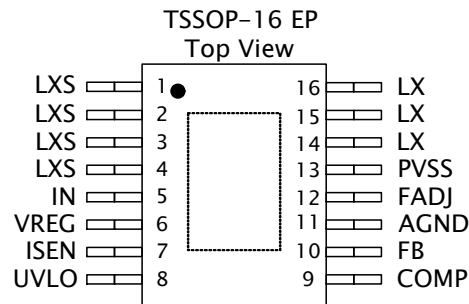

| Pin No.  | Pin  | I/O/P | Function Description   |
|----------|------|-------|--|
| 1,2,3,4  | LXS  | O     | Current Output. Internal MOSFET Source Current Output. Connected this terminal to current sense resistor.  |
| 5        | IN   | P     | Power Supply Input.  |
| 6        | VREG | I     | Driver Supply Voltage. A bypass capacitor must be connected from this pin to ground. Do not bias this pin with external power source.  |
| 7        | ISEN | I     | Current Sense. Use an external resistor in series with ground to measure the voltage drop.   |
| 8        | UVLO | I     | Under Voltage Lockout. Use a proper ratio resistor divider network to determine the voltage input to allow switching and the hysteresis to disable switching.  |
| 9        | COMP | I     | Compensation. Use a proper RC/C network to do proper loop compensation.  |
| 10       | FB   | I     | Output Feedback. Connect the external resistor divider network from output to this pin to sense output voltage. The FB pin voltage is regulated to internal 1.275V reference voltage.  |
| 11       | AGND | P     | Analog Ground. Connect to system signal ground.  |
| 12       | FADJ | I     | Frequency Adjust/Synchronization/Shutdown. A resistor connected from this pin to ground simply sets the oscillator frequency. An external clock signal at this pin will synchronize the controller to the clock. Pull on this pin for $\geq 30 \mu\text{s}$ will turn the device off and the device will then very few current about $5\mu\text{A}$ from the supply. |
| 13       | PVSS | P     | Power Ground. Connect to system power ground.  |
| 14,15,16 | LX   | O     | Switch Node. LX is the switching node that supplies power to the output.   |
| EP       | LX   | O     | Switch Node. Connect the exposed pad and reserve enough cooper size for heat-sinking.  |

## Absolutely Maximum Ratings

Over operating free-air temperature range, unless otherwise specified (\* 1)

| Symbol                       | Parameter                             | Limit       | Unit |
|------------------------------|---------------------------------------|-------------|------|
| $V_{IN}$                     | Supply voltage range                  | -0.3 to 30  | V    |
| $V_{LX}$                     | Switch node voltage                   | -0.3 to 33  | V    |
| $V_{LV}$ (COMP/UVLO/FB/FADJ) | Low voltage range                     | -0.3 to 6   | V    |
| $V_{CC}$ (VREG)              | Regulator output pin range            | -0.3 to 5   | V    |
| $V_{ISEN}$                   | Current sense pin range               | -0.4 to 0.6 | V    |
| $T_J$                        | Operating junction temperature range  | -40 to 150  | °C   |
| $T_{STG}$                    | Storage temperature range             | -65 to 150  | °C   |
| Electrostatic discharge      | Human body model                      | 2           | kV   |
| Electrostatic discharge      | Machine model                         | 200         | V    |
| $\theta_{JC}$                | Thermal resistance (Junction to Case) | 55          | °C/W |
| $\theta_{JA}$                | Thermal resistance (Junction to Air)  | 160         | °C/W |

(\*1): Stress beyond those listed at "absolute maximum rating" table may cause permanent damage to the device. These are stress rating ONLY. For functional operation are strongly recommend follow up "recommended operation conditions" table.

## Recommended Operating Conditions

| Symbol    | Parameter                            | Specification |      | Unit |
|-----------|--------------------------------------|---------------|------|------|
|           |                                      | Min           | Max  |      |
| $V_{IN}$  | Supply voltage                       | 6             | 25   | V    |
| $f_{OSC}$ | Switching voltage range              | 100           | 1000 | kHz  |
| $T_A$     | Operating free-air temperature range | -40           | 85   | °C   |
| $T_J$     | Operating Junction range             | -40           | 125  | °C   |

## Electrical Characteristics

$V_{IN}=12V$ ,  $R_{FADJ}=40k\Omega$ ,  $T_J=25^\circ C$ , unless otherwise specified (\* 1)

| Symbol            | Parameter                                  | Test Condition   | Specification                                       |           |       | Unit       |    |
|-------------------|--|--|---|-----------|-------|------------|----|
|                   |  |  | Min   | Typ       | Max   |            |    |
| $V_{FB}$          | Feedback voltage                           | $V_{COMP}=1.4V$ , $3V < V_{IN} < 40V$  |   | 1.275     |       | V          |    |
|                   |  | $V_{COMP}=1.4V$ , $3V < V_{IN} < 40V$ ,<br>$-40^\circ C < T_J < 125^\circ C$ | 1.256   |           | 1.294 | V          |    |
| $I_Q$             | Quiescent current in shutdown mode         | $V_{FADJ}=3V$  | $V_{IN}=12V$  |           | 10    | $\mu A$    |    |
|                   |  |  | $V_{IN}=12V$ ,<br>$-40^\circ C < T_J < 125^\circ C$ |           |       |            | 15 |
|                   |  |  | $V_{IN}=6V$   |           | 5     |            |    |
|                   |  |  | $V_{IN}=6V$ ,<br>$-40^\circ C < T_J < 125^\circ C$  |           |       |            | 10 |
| $V_{UVLO}$        | Under voltage lockout                      | $V_{UVLO}$ Ramp down   | 1.345   |           | 1.517 | V          |    |
| $I_{UVLO}$        | UVLO source current                        | $V_{EN} = 3V$  |   | 4.5       |       | $\mu A$    |    |
| $V_{UVLOSD}$      | UVLO Shutdown voltage                      |  | 0.55  | 0.7       | 0.82  | V          |    |
| $V_{COMP}$        | COMP pin voltage                           | $V_{EN}=2V$  |   | 1         |       | V          |    |
| $I_{COMP}$        | COMP pin current sink                      | $V_{FB}=0V$  |   | 630       |       | $\mu A$    |    |
| $R_{DS(ON)}$      | Internal low-side switch $R_{DS(ON)}$ (*1) | $V_{IN}=6V$ , $I_{MOSFET}=0.2A$  |   | 15        |       | m $\Omega$ |    |
| $A_{VOL}$         | Error amplifier voltage gain               | $V_{COMP}=1.4V$ , $I_{EAO}=100\mu A$   |   | 60        |       | V/V        |    |
| $g_M$             | Error amplifier trans-conductance          | $V_{COMP}=1.4V$  |   | 430       |       | $\mu S$    |    |
| $f_{OSC}$         | Oscillation frequency                      | $R_{FADJ}=40k\Omega$   | 0.4   | 0.475     | 0.555 | MHz        |    |
| $D_{MAX}$         | Maximum duty cycle                         | $R_{FADJ}=40k\Omega$   |   | 85        |       | %          |    |
| $\Delta V_{LINE}$ | Voltage line regulation                    | $6V < V_{EN} < 24V$  |   | 0.02      |       | %/V        |    |
| $\Delta V_{LOAD}$ | Voltage load regulation                    | $I_{EAO}$ Source/Sink  |   | $\pm 0.5$ |       | %/A        |    |
| $t_{MIN(ON)}$     | Minimum on-time                            |  |   |           | 571   | nS         |    |
| $I_{SUPPLY}$      | Supply Current                             | $R_{FADJ}=40k\Omega$   |   | 3.3       |       | mA         |    |
| $V_{SENSE}$       | Current sense threshold voltage            |  | 100   |           | 190   | mV         |    |
| $V_{SC}$          | Overload current limit sense voltage       |  | 157   |           | 280   | mV         |    |
| $V_{SL}$          | Internal compensation ramp                 |  |   | 90        |       | mV         |    |
| $V_{OVP}$         | Output overvoltage protection              | $V_{COMP}=1.4V$  | 26  | 85        | 135   | mV         |    |
| $V_{OVP(HYS)}$    | Output overvoltage protection hysteresis   | $V_{COMP}=1.4V$  | 28  | 70        | 106   | mV         |    |

(\*1): Integrated N-MOSFET

## Electrical Characteristics (cont.)

$V_{IN}=12V$ ,  $R_{FADJ}=40k\Omega$ ,  $T_J=25^\circ C$ , unless otherwise specified (\* 1)

| Symbol        | Parameter                                    | Test Condition   | Specification |      |      | Unit       |
|---------------|--|--|---------------|------|------|------------|
|               |  |  | Min           | Typ  | Max  |            |
| $I_{EAO}$     | Error amplifier output current (Source/Sink) | Source, $V_{COMP} = 1.4V$ , $V_{FB} = 1.1V$                                      |               | 630  |      | $\mu A$    |
|               |  | Source, $V_{COMP} = 1.4V$ , $V_{FB} = 1.1V$<br>$-40^\circ C < T_J < 125^\circ C$ | 470           |      | 840  |            |
|               |  | Sink, $V_{COMP} = 1.4V$ , $V_{FB} = 1.4V$  |               | 75   |      |            |
|               |  | Sink, $V_{COMP} = 1.4V$ , $V_{FB} = 1.4V$<br>$-40^\circ C < T_J < 125^\circ C$   | 30            |      | 105  |            |
| $V_{EAO}$     | Error amplifier output voltage               | $V_{FB}=0V$ , COMP pin floating  |               | 2.65 |      | V          |
|               |  | $V_{FB}=0V$ , COMP pin floating<br>$-40^\circ C < T_J < 125^\circ C$             | 2.45          |      | 2.95 |            |
|               |  | $V_{FB}=1.4V$  |               | 0.66 |      |            |
|               |  | $V_{FB}=1.4V$<br>$-40^\circ C < T_J < 125^\circ C$                               | 0.32          |      | 0.9  |            |
| $V_{SD}$      | Shutdown signal threshold on FADJ pin        | Chip Enable  |               | 1.26 |      | V          |
|               |  | Chip Enable, $-40^\circ C < T_J < 125^\circ C$                                   |               |      | 1.4  |            |
|               |  | Chip Disable   |               | 0.63 |      |            |
|               |  | Chip Disable, $-40^\circ C < T_J < 125^\circ C$                                  | 0.4           |      |      |            |
| $t_{SS}$      | Soft start delay                             | $V_{FB} = 1.2V$ , COMP pin floating  | 8.7           | 15   | 21.3 | mS         |
| $I_{SD}$      | Shutdown pin current FADJ pin                | $V_{SD}=0V$  |               | 20   |      | $\mu A$    |
| $T_{SD}$      | Thermal shutdown                             |  |               | 175  |      | $^\circ C$ |
| $T_{SD(HYS)}$ | Thermal shutdown hysteresis                  |  |               | 10   |      | $^\circ C$ |

(\*1): Stress beyond those listed at "absolute maximum rating" table may cause permanent damage to the device. These are stress rating ONLY. For functional operation are strongly recommend follow up "recommended operation conditions" table.

## Functional Descriptions

The VP3379 employs the current-mode, adjustable frequency pulse-width modulation (PWM) architecture. It operates at adjustable switching frequency under medium to high load current conditions.

### Overvoltage and UVLO Protection

The VP3379 uses FB pin to detect overvoltage occurrence. The overvoltage protection should be triggered at the voltage rises to  $V_{FB} + V_{OVP}$ . When OVP occurs only the MOSFET will be turned off, the output voltage will drop. VP3379 will switch when the voltage on FB pin is less then  $(V_{OVP} + V_{FB} - V_{OVP(HYS)})$ .

The VP3379 provides UVLO pin to program enable and disable thresholds. The voltage on UVLO pin would be compared with internal reference 1.43V. Figure 1 shows how the UVLO detection works.

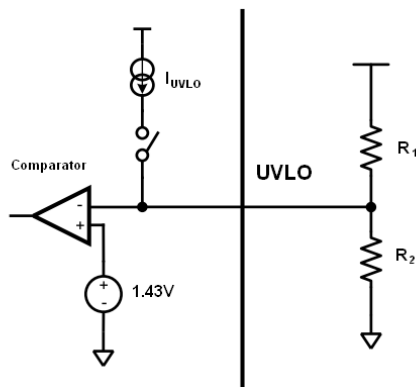

Figure 1. UVLO Pin Configuration

The R1/R2 network programs the enable threshold voltage  $V_{EN}$ . When the VP3379 is enabled the  $I_{UVLO}$  will source 5 $\mu$ A current flows the  $R_2$  which causes a hysteresis. Hence the disable threshold,  $V_{SH}$ , is lower then the enable threshold  $V_{EN}$ .

$$R_2 = \frac{1.43V}{I_{UVLO}} \times \left( 1 + \frac{1.43V - V_{SH}}{V_{EN} - 1.43V} \right)$$

$$R_1 = R_2 \times \left( \frac{V_{EN}}{1.43V} - 1 \right)$$

Select appropriate value of  $V_{EN}$ ,  $V_{SH}$  and use above two equations to determine the value of  $R_1$  and  $R_2$ .

### Bias Voltage

VP3379 generates the internal bias voltage from IN input voltage if it does not exceeds 6V. When  $V_{IN}$  is higher then 6V the VP3379 will use internal regulation to bias the chip. To improve the stability of the bias, an external capacitor of 0.47 $\mu$ F~4.7 $\mu$ F is strongly recommended to add on VREG terminal.

In any case, do not add external voltage on VREG pin or the chip would be damaged.

### Frequency Adjust

The switching frequency can be adjusted from 100kHz to 1MHz by a external resistor in series with FADJ terminal and ground. The following equation is used to calculate resistor value.

$$R_{FADJ} = \frac{22 \times 10^3}{f_s} - 5.74$$

Where  $f_s$  is in kHz and  $R_{FADJ}$  is in k $\Omega$ .

### Clock Synchronization

VP3379 is able to be synchronized to an external clock by connecting to the FADJ terminal with  $R_{FADJ}$  in series with ground as shown in figure 2.

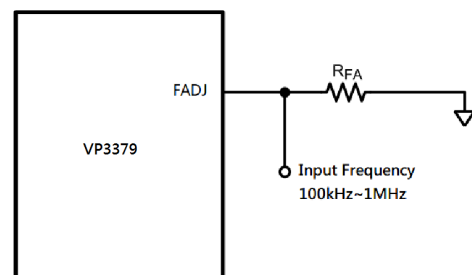

Figure 2. Clock Synchronization

### Shutdown

## Functional Descriptions (cont.)

The FADJ pin can be used as a shutdown pin. If the high signal pulls up this pin, VP3379 will stop the switching and then enter the shutdown state. In this state, VP3379 consumes only 5 $\mu$ A typically.

The use of shutdown control in frequency adjustment mode is quite simple. Connects the FADJ pin to ground will force the VP3379 runs at specified frequency and pulls this pin high will shutdown the IC. In both frequency and synchronization mode, pulls FADJ pin high lasting then 30 $\mu$ s will also force the VP3379 enter the shutdown state.

be activated. The comparator will decrease the switching frequency by the factor of 8 and maintains this condition until the over-current (short) event is removed.

## Slope Compensation

VP3379 employs current mode control scheme. It has many advantages such as cycle-by-cycle current limit for the switch and easier to parallel power stages because automatic current sharing. The compensation ramp is already added in VP3379 and the slope of the default compensation ramp could satisfy most applications.

## Overvoltage Protection

The VP3379 has overvoltage protection for the output. OVP occurrence is detected by sensing feedback (FB) pin. When the voltage at FB pin is over  $V_{FB} + V_{OVP}$ , overvoltage protection is triggered and the drive pin and the GATE pin will be tied-low.

Once the voltage at FB pin is lower than  $V_{FB} + (V_{OVP} - V_{OVP(HYS)})$ , the VP3379 will begin to switch again. Be aware that the error amplifier is still in operation during OVP event.

## Short Circuit Protection

The ISEN pin is used to sense the over-current occurrence. If the difference between ISEN pin and ground is greater than 220mV, the current limit will

## Application Information

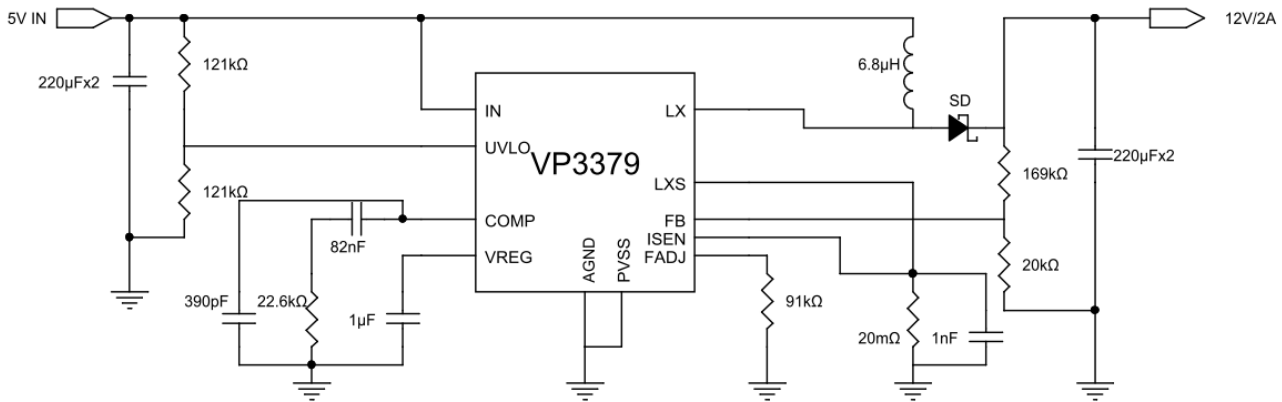

Figure 3 VP3379 Typical Boost Application

The most common topology for the VP3379 is the boost or step-up topology. The boost converter converts a low input voltage into a higher output voltage. The basic configuration for a boost regulator is shown in Figure 4. In continuous conduction mode (when the inductor current never reaches zero at steady state), the boost regulator operates in two cycles. In the first cycle of operation, MOSFET Q is turned on and energy is stored in the inductor. During this cycle, diode D1 is reverse biased and load current is supplied by the output capacitor,  $C_{OUT}$ . In the second cycle, MOSFET Q is off and the diode is forward biased. The energy stored in the inductor is transferred to the load and output capacitor. The ratio of these two cycles determines the output voltage. The output voltage is defined as:

$$V_{OUT} = \frac{V_{IN}}{1 - D}$$

(ignoring the voltage drop across the MOSFET and the diode), or

$$V_{OUT} + V_{D1} - V_Q = \frac{V_{IN} - V_Q}{1 - D}$$

where D is the duty cycle of the switch,  $V_{D1}$  is the forward voltage drop of the diode, and  $V_Q$  is the drop across the MOSFET when it is on. The following sections describe selection of components for a boost converter.

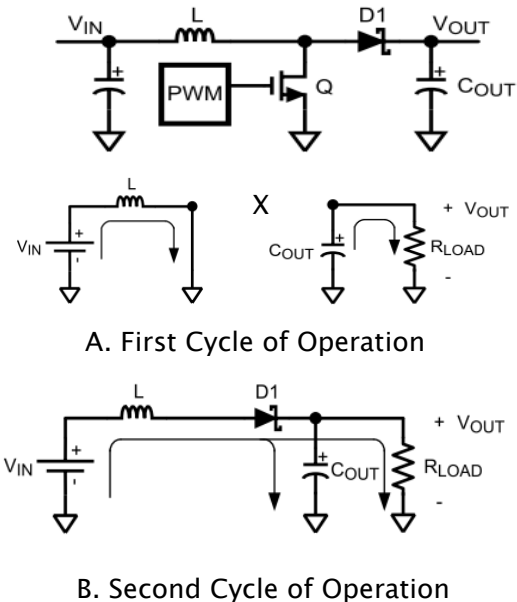

Figure 4. Simplified Boost Converter Diagram

### Power Inductor Selection

The inductor is one of the two energy storage elements in a boost converter. Figure 5 shows how the inductor current varies during a switching cycle. The current through an inductor is quantified as:

$$V_L(t) = L \frac{di_L(t)}{dt}$$



## Application Information (cont.)

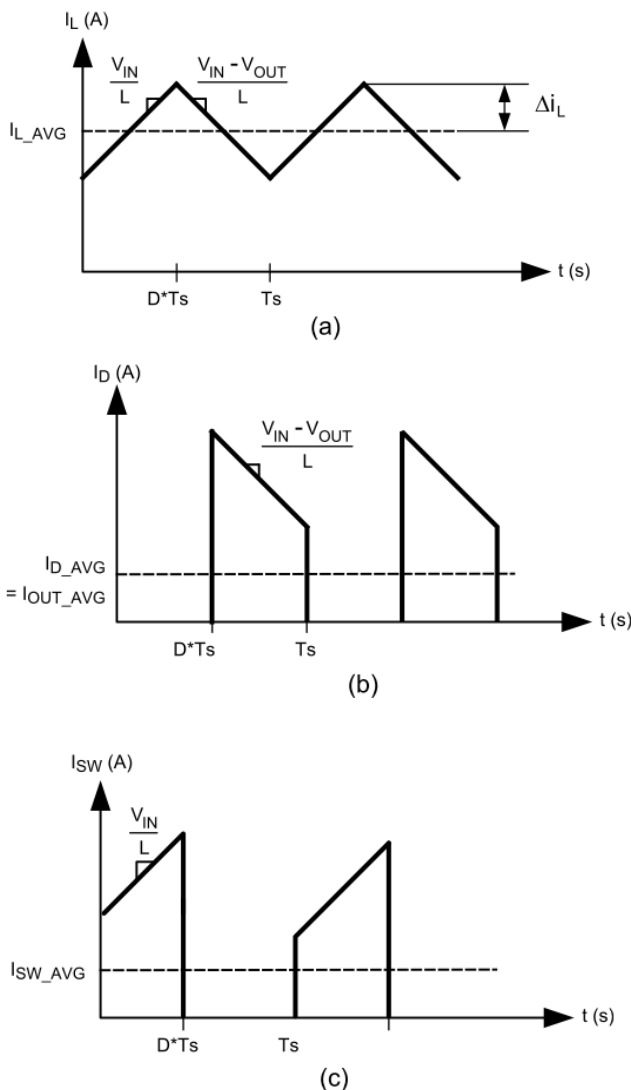

Figure 5. (a) Inductor Current (b) Diode Current (c) Switch Current

If  $V_L(t)$  is constant,  $di_L(t)/dt$  must be constant. Hence, for a given input voltage and output voltage, the current in the inductor changes at a constant rate.

The important quantities in determining a proper inductance value are  $I_L$  (the average inductor current) and  $\Delta i_L$  (the inductor current ripple difference between the peak inductor current and the average inductor current). If  $\Delta i_L$  is larger than  $I_L$ , the inductor current drops to zero for a portion of the

cycle and the converter operates in discontinuous conduction mode. If  $\Delta i_L$  is smaller than  $I_L$ , the inductor current stays above zero and the converter operates in continuous conduction mode. All the analysis in this data sheet assumes operation in continuous conduction mode. To operate in continuous conduction mode, the following conditions must be met:

- (1)  $I_L > \Delta i_L$
- (2)  $\frac{I_{OUT}}{1-D} > \frac{DV_{IN}}{2f_s L}$
- (3)  $L > \frac{D(1-D)V_{IN}}{2I_{OUT}f_s}$

Choose the minimum  $I_{OUT}$  to determine the minimum  $L$ . A common choice is to set  $(2 \times \Delta i_L)$  to 30% of  $I_L$ . Choosing an appropriate core size for the inductor involves calculating the average and peak currents expected through the inductor. In a boost converter,

- (4)  $I_L = \frac{I_{OUT}}{1-D}$
- (5)  $I_{L\_PEAK} = I_L(\max) + \Delta i_L(\max)$
- (6)  $\Delta i_L = \frac{DV_{IN}}{2 \times L \times f_s}$

A core size with ratings higher than these values should be chosen. If the core is not properly rated, saturation will dramatically reduce overall efficiency.

The VP3379 can be set to switch at very high frequencies. When the switching frequency is high, the converter can operate with very small inductor values. With a small inductor value, the peak inductor current can be extremely higher than the output currents, especially under light load conditions.

## Application Information (cont.)

The VP3379 senses the peak current through the built-in MOSFET switch. The peak current through the switch is the same as the peak current calculated above.

### Programming the Output Voltage and Output Current

The output voltage can be programmed using a resistor divider between the output and the feedback pins, as shown in Figure 6. The resistors are selected such that the voltage at the feedback pin is 1.275V.  $R_{F1}$  and  $R_{F2}$  can be selected using the equation,

$$V_{OUT} = 1.275 \left( 1 + \frac{R_{F1}}{R_{F2}} \right)$$

A 100pF capacitor may be connected between the feedback and ground pins to reduce noise.

The maximum amount of current that can be delivered at the output can be controlled by the sense resistor,  $R_{SEN}$ . Current limit occurs when the voltage that is generated across the sense resistor equals the current sense threshold voltage,  $V_{SENSE}$ . Limits for  $V_{SENSE}$  have been specified in the Electrical Characteristics section. This can be expressed as:

$$I_{SW(peak)} \times R_{SEN} = V_{SENSE} - D \times V_{SL}$$

The peak current through the switch is equal to the peak inductor current.

$$I_{SW(peak)} = I_L(\max) + \Delta i_L$$

Therefore for a boost converter,

$$I_{SW(peak)} = \frac{I_{OUT(max)}}{(1-D)} + \frac{(D \times V_{IN})}{(2 \times f_s \times L)}$$

Combining the two equations yields an expression for  $R_{SEN}$ ,

$$R_{SEN} = \frac{V_{SENSE} - (D \times V_{SL})}{\left[ \frac{I_{OUT(max)}}{(1-D)} + \frac{(D \times V_{IN})}{(2 \times f_s \times L)} \right]}$$

Evaluate  $R_{SEN}$  at the maximum and minimum  $V_{IN}$  values and choose the smallest  $R_{SEN}$  calculated.

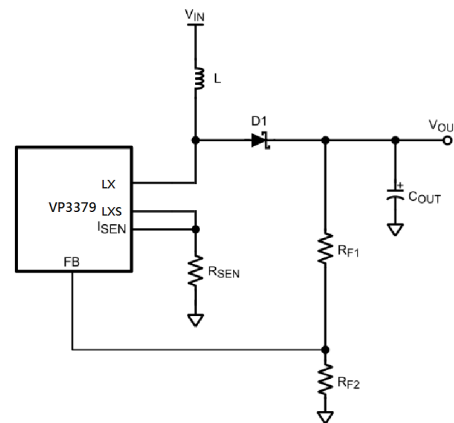

Figure 6. Adjusting the Output Voltage

### Power Diode Selection

Observation of the boost converter circuit shows that the average current through the diode is the average load current, and the peak current through the diode is the peak current through the inductor. The diode should be rated to handle more than the inductor peak current. The peak diode current can be calculated using the formula:

$$I_{D(Peak)} = [I_{OUT} / (1-D)] + \Delta i_L$$

$I_{OUT}$  is the output current and  $\Delta i_L$  has been defined in Figure 5. The peak reverse voltage for a boost converter is equal to the regulator output voltage. The diode must be capable of handling this peak reverse voltage. To improve efficiency, a low forward drop Schottky diode is recommended.

## Application Information (cont.)

### Input Capacitor Selection

Due to the presence of an inductor at the input of a boost converter, the input current waveform is continuous and triangular, as shown in Figure 5. The inductor ensures that the input capacitor sees fairly low ripple currents. However, as the input capacitor gets smaller, the input ripple goes up. The rms current in the input capacitor is given by:

$$I_{CIN(RMS)} = \Delta i_L / \sqrt{3} = \left( \frac{(V_{OUT} - V_{IN}) \times V_{IN}}{\sqrt{12} \times V_{OUT} \times L \times f_s} \right)$$

The input capacitor should be capable of handling the rms current. Although the input capacitor is not as critical in a boost application, low values can cause impedance interactions. Therefore a good quality capacitor should be chosen in the range of 100uF to 200uF. If a value lower than 100 uF is used, then problems with impedance interactions or switching noise can affect the VP3481. To improve performance, especially with  $V_{IN}$  below 8 V, it is recommended to use a 20Ω resistor at the input to provide a RC filter. This resistor is placed in series with the  $V_{IN}$  pin with only a bypass capacitor attached to the  $V_{IN}$  pin directly (see Figure 7). A 0.1uF or 1uF ceramic capacitor is necessary in this configuration. The bulk input capacitor and inductor will connect on the other side of the resistor with the input power supply.

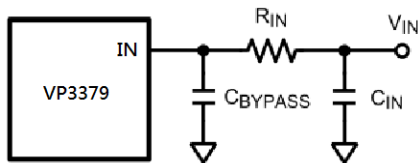

Figure 7 Reducing IC Input Noise

### Driver Supply Capacitor Selection

A good quality ceramic bypass capacitor must be connected from the  $V_{CC}$  pin to the  $PGND$  pin for proper operation. This capacitor supplies the transient current required by the internal MOSFET driver, as well as filtering the internal supply voltage

for the controller. A value of between 0.47uF and 4.7uF is recommended.

### Output Capacitor Selection

The output capacitor in a boost converter provides all the output current when the inductor is charging. As a result it sees very large ripple currents. The output capacitor should be capable of handling the maximum rms current. The rms current in the output capacitor is:

$$I_{CIN(RMS)} = \sqrt{(1-D) \left[ I_{OUT}^2 \frac{D}{(1-D)^2} + \frac{\Delta i_L^2}{3} \right]}$$

Where

$$\Delta i_L = \frac{DV_{IN}}{2 \times L \times f_s}$$

and D, the duty cycle is equal to  $(V_{OUT} - V_{IN}) / V_{OUT}$ .

The ESR and ESL of the output capacitor directly control the output ripple. Use capacitors with low ESR and ESL at the output for high efficiency and low ripple voltage. Surface mount tantalums, surface mount polymer electrolytic and polymer tantalum, Sanyo- OSCON, or multi-layer ceramic capacitors are recommended at the output.

## Application Information (cont.)

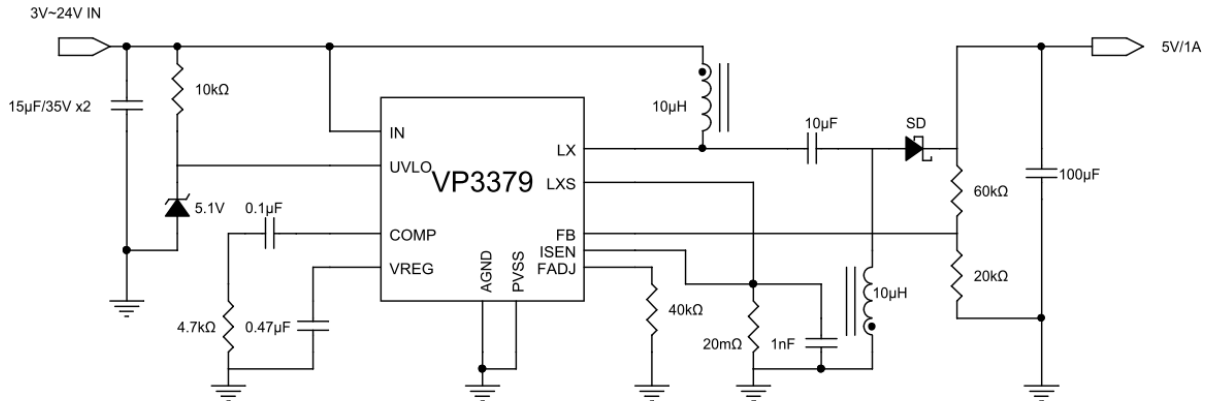

Figure8 VP3379 Typical SEPIC Application

VP3379 can also be used in SEPIC application because of it controls low-side of NMOSFET. Figure 8 shows the VP3379 typical SEPIC application. This configuration allows the input voltage higher or lower than output voltage. For both stepping-up and stepping-down configuration, two inductors are needed. The two inductors can be individual inductor or two windings of a coupled transformer. For reducing input ripple it is better to use the coupled windings of transformers for both inductors.

The advantage of SEPIC structure over a boost converter is input and output isolation. The input and the output of pure boost converter is always connected through an inductor unless external switch is added. For SEPIC structure, a capacitor isolates the input from the output and provides protection against shorted or malfunctioning load. Hence, the SEPIC is useful for replacing boost circuits when true shutdown is required. This means that the output voltage falls to 0V when the switch is turned off. In pure boost converter, the output can only fall to the input voltage minus a diode drop and never turn off the output.

To properly pick up the components for the application, the following parameters need to be exam-

ined: Input voltage range, output voltage, output current range and the switching frequency. These four main parameters will affect the operating characteristic of the application.

### Power Diode Selection

The diode must be selected to handle the peak current and the peak reverse voltage. In SEPIC application, the diode peak current is the same as the switch peak current. The off-state voltage or peak reverse voltage of the diode is  $V_{IN} + V_{OUT}$ . Similar to the boost converter, the average diode current is equal to the output current. In order to improve the efficiency, schottky diodes are recommended.

### Inductor Selection

The inductors shall be chosen carefully to satisfy constant current mode requires calculations of the following parameters:

Inductor average current:

$$I_{L1(AVG)} = \frac{D \times I_{OUT}}{1 - D}$$

$$I_{L2(AVG)} = I_{OUT}$$

Peak-to-peak ripple current:

## Application Information (cont.)

$$\Delta I_{L1} = \frac{D \times (V_{IN} - V_Q)}{f_s \times L_1}$$

$$\Delta I_{L2} = \frac{D \times (V_{IN} - V_Q)}{f_s \times L_2}$$

Maintaining the condition  $I_L > \Delta I_L / 2$  to ensure continuous conduction mode yields the following minimum values for  $L_1$  and  $L_2$ :

$$L_1 > \frac{(1 - D) \times (V_{IN} - V_Q)}{f_s \times I_{OUT} \times 2}$$

$$L_2 > \frac{D \times (V_{IN} - V_Q)}{f_s \times I_{OUT} \times 2}$$

Peak current in the inductor, to ensure the inductor does not saturate:

$$I_{L1(PK)} = \frac{D \times I_{OUT}}{1 - D} + \frac{\Delta I_{L1}}{2}$$

$$I_{L2(PK)} = I_{OUT} + \frac{\Delta I_{L2}}{2}$$

$I_{L1(PK)}$  must be lower than the maximum current rating set by the current sense resistor.

The value of  $L_1$  can be increased above the minimum recommended value to reduce input ripple and output ripple. However, once  $\Delta I_{L1}$  is less than 20% of  $I_{L1(AVG)}$ , the benefit to output ripple is minimal.

By increasing the value of  $L_2$  above the minimum recommendation,  $\Delta I_{L2}$  can be reduced, which in turn will reduce the output ripple voltage:

$$\Delta V_{OUT} = \left( \frac{I_{OUT}}{1 - D} + \frac{\Delta I_{L2}}{2} \right) \times ESR$$

where ESR is the equivalent series resistance of the output capacitor.

If  $L_1$  and  $L_2$  are wound on the same core, then  $L_1 = L_2 = L$ . All the equations above will hold true if the inductance is replaced by  $2L$ .

### Input Capacitor Selection

Like boost structure, SEPIC has an inductor at the

input. The inductor ensures that the input capacitor sees fairly low ripple currents and the capacitor should be capable of handling the input RMS current. In SEPIC application, lower values can cause impedance interactions. Therefore a good quality capacitor such as polymer tantalum, OS-con or multilayer ceramic capacitors is recommended in the range from 100  $\mu$ F to 200  $\mu$ F.

To improve the performance especially when  $V_{IN}$  is under 8V, the input RC low pass filter could be added. Refer the input capacitor selection in boost controller application for details.

### Output Capacitor Selection

The output capacitors directly affect the output ripple. Use capacitors with low ESR and ESL at the output for higher efficiency and lower ripple voltage. Surface mount tantalums, surface mount polymer electrolytic and polymer tantalum, OS-Con, or multi-layer ceramic capacitors are recommended at the output for low ripple.

### Resistor Selection

The peak current through the MOSFET,  $I_{SW(PEAK)}$ , can be adjusted using the current sense resistor,  $R_{SEN}$ , to limit at certain output current.  $R_{SEN}$  can be selected using the following equation:

$$R_{SEN} = \frac{V_{SENSE} - D \times (V_{SL} + \Delta V_{SL})}{I_{SW(PEAK)}}$$

### Isolation Capacitor Selection

The isolation capacitor  $C_s$ , depends on the rms current. The rms current of the SEPIC capacitor is given by:

$$I_{CSRMS} = \sqrt{I_{SWRMS}^2 + (I_{L1PK}^2 - I_{L1PK} \Delta I_{L1} + \Delta I_{L1}^2)(1 - D)}$$

The isolation capacitor must be rated for a large ACrms current relative to the output power. This property makes the SEPIC much better suited to lower power applications where the rms current

## Application Information (cont.)

through the capacitor is small (relative to capacitor technology). The voltage rating of the isolation capacitor must be greater than the maximum input voltage. Tantalum capacitors are the best choice for SMT, having high rms current ratings relative to size. Ceramic capacitors could be used, but the low C values will tend to cause larger changes in voltage across the capacitor due to the large currents, and high C value ceramics are expensive. Electrolytics work well for through hole applications where the size required to meet the rms current rating can be accommodated. There is an energy balance between C S and L1, which can be used to determine the value of the capacitor. The basic energy balance equation is:

$$\frac{1}{2}C_S\Delta V_S^2 = \frac{1}{2}(L1)\Delta I_{L1}^2$$

Where

$$\Delta V_S = \left( \frac{V_{OUT}}{V_{OUT} + V_{IN} - V_Q + V_{DIODE}} \right) \times \frac{I_{OUT}}{f_S C_S}$$

is the ripple voltage across the isolation capacitor, and

$$\Delta I_{L1} = \frac{(V_{IN} - V_Q) \times D}{(L1)f_S}$$

is the ripple current through the inductor L1. The energy balance equation can be solved to provide a minimum value for Cs :

$$C_S \geq L1 \frac{I_{OUT}^2}{(V_{IN} - V_Q)^2}$$

## Package Information

### TSSOP-16

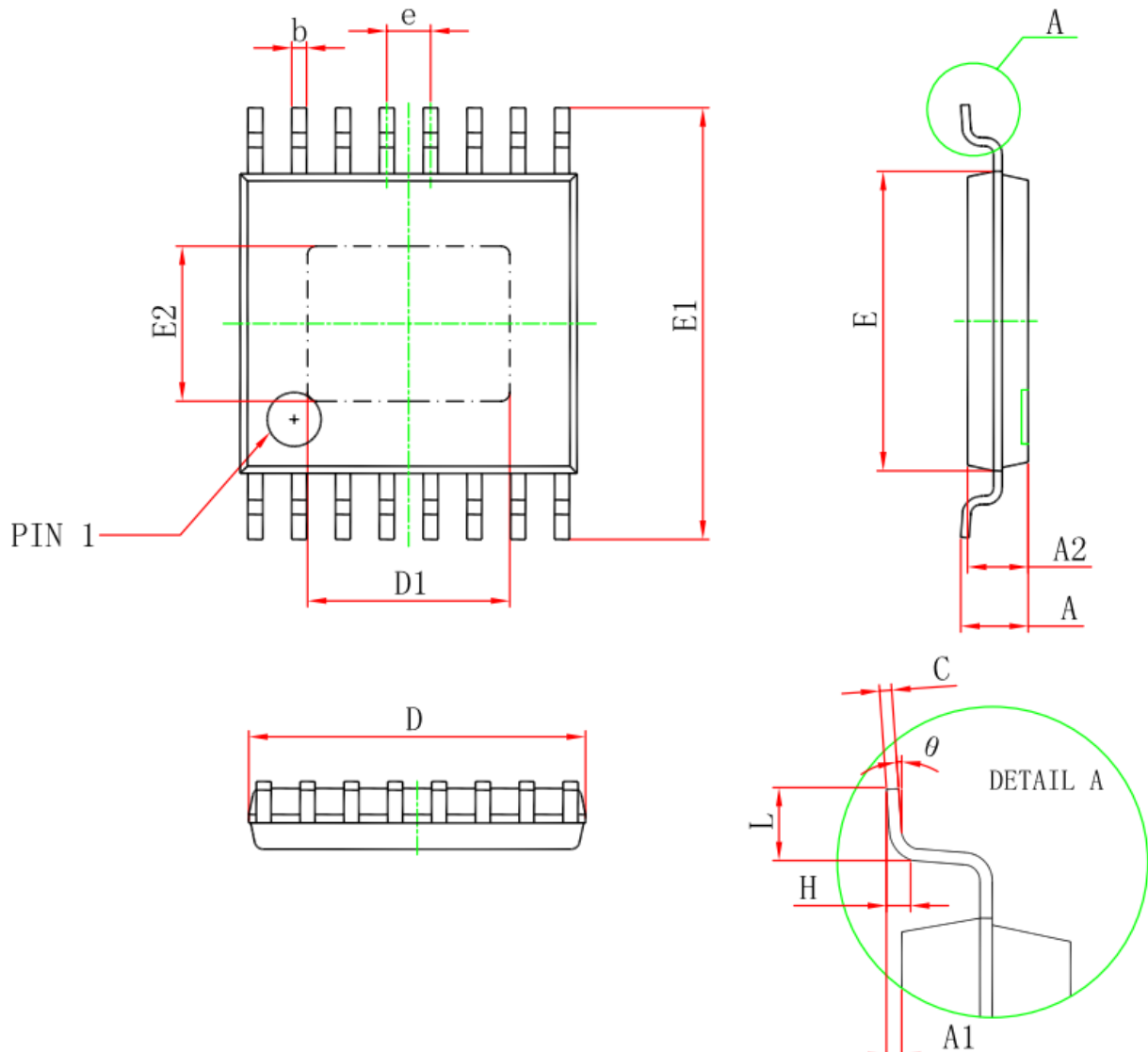

| Symbol   | Dimensions In Millimeters |       | Dimensions In Inches |       |
|----------|---------------------------|-------|----------------------|-------|
|          | Min                       | Max   | Min                  | Max   |
| D        | 4.900                     | 5.100 | 0.193                | 0.201 |
| D1       | 2.900                     | 3.100 | 0.114                | 0.122 |
| E        | 4.300                     | 4.500 | 0.169                | 0.177 |
| b        | 0.190                     | 0.300 | 0.007                | 0.012 |
| c        | 0.090                     | 0.200 | 0.004                | 0.008 |
| E1       | 6.250                     | 6.550 | 0.246                | 0.258 |
| E2       | 2.200                     | 2.400 | 0.087                | 0.094 |
| A        |                           | 1.150 |                      | 0.043 |
| A2       | 0.800                     | 1.000 | 0.031                | 0.039 |
| A1       | 0.020                     | 0.150 | 0.001                | 0.006 |
| e        | 0.65 (BSC)                |       | 0.026 (BSC)          |       |
| L        | 0.500                     | 0.700 | 0.02                 | 0.028 |
| H        | 0.25 (TYP)                |       | 0.01 (TYP)           |       |
| $\theta$ | 1°                        | 7°    | 1°                   | 7°    |

## Contact Information

### Viva Electronics Incorporated

10F-1, No. 32, Gaotie 2<sup>nd</sup> Rd., Zhubei City, Hsinchu County, Taiwan, R.O.C.

Tel: 886-3-6579508

Fax: 886-3-6579509

WWW: <http://www.viva-elec.com.tw>

Sales: [sales@viva-elec.com.tw](mailto:sales@viva-elec.com.tw)

FAE Support: [fae@viva-elec.com.tw](mailto:fae@viva-elec.com.tw)

### IMPORTANT NOTICE

Viva Electronics Incorporated reserves the right to make changes without further notice to any products or specifications herein. Viva Electronics Incorporated does not assume any responsibility for use of any its products for any particular purpose, nor does Viva Electronics Incorporated assume any liability arising out of the application or use of any its products or circuits. Viva Electronics Incorporated does not convey any license under its patent rights or other rights nor the rights of others.



## X-ON Electronics

Largest Supplier of Electrical and Electronic Components

*Click to view similar products for [Switching Controllers](#) category:*

*Click to view products by [VIVA](#) manufacturer:*

Other Similar products are found below :

[LV5065VB-TLM-H](#) [LV5066V-TLM-H](#) [LV5725JAZ-AH](#) [NCP1218AD65R2G](#) [NCP1234AD100R2G](#) [NCP1244BD065R2G](#) [NCP1336ADR2G](#)  
[NCP6153MNTWG](#) [NCP81005MNTWG](#) [NCP81101BMNTXG](#) [NCP81205MNTXG](#) [SJ6522AG](#) [SJE6600](#) [AZ7500BMTR-E1](#)  
[IR35215MTRPBF](#) [SG3845DM](#) [NCP4204MNTXG](#) [NCP6132AMNR2G](#) [NCP81102MNTXG](#) [NCP81206MNTXG](#) [UBA2051C](#)  
[NCP1240AD065R2G](#) [NCP1240FD065R2G](#) [NCP1361BABAYSNT1G](#) [NCP1230P100G](#) [NX2124CSTR](#) [SG2845M](#) [NCP1366BABAYDR2G](#)  
[NCP81101MNTXG](#) [TEA19362T/1J](#) [NCP81174NMNTXG](#) [NCP4308DMTTWG](#) [NCP4308DMNTWG](#) [NCP4308AMTTWG](#)  
[NCP1366AABAYDR2G](#) [NCP1251FSN65T1G](#) [NCP1246BLD065R2G](#) [iW1760B-10](#) [MB39A136PFT-G-BND-ERE1](#) [NCP1256BSN100T1G](#)  
[LV5768V-A-TLM-E](#) [NCP1365BABCYDR2G](#) [NCP1365AABCYDR2G](#) [MCP1633T-E/MG](#) [MCP1633-E/MG](#) [NCV1397ADR2G](#)  
[NCP81599MNTXG](#) [NCP1246ALD065R2G](#) [AZ494AP-E1](#) [NCP1247BD065R2G](#)