

THERMAL COMPOUNDS, ADHESIVES AND INTERFACE MATERIALS

120 SERIES



The **120 Series** Silicone Oil-Based Thermal Joint Compound fills the minute air gap between mating surfaces with a grease-like material containing zinc oxide in a silicone oil carrier. It possesses an excellent thermal resistance of only 0.05°C/W for a 0.001 in. film with an area of one square inch. There is no measurable increase in case temperature of a mounted semiconductor on a heat sink after the 6-month stabilization period (Time versus Thermal Resistivity graph below).

| TYPICAL VALUES FOR THERMAL RESISTANCE, CASE TO SINK (θ_{CS}) WHEN THERMAL JOINT COMPOUNDS ARE USED | | |
|---|--|-----------------------------------|
| Case Style Characteristics | Mounting Torque in inch • pounds (N•M) | Typical Thermal Resistance (°C/W) |
| TO-3 | 8 (0.9) | 0.09 |
| TO-66 | 9 (0.9) | 0.14 |
| TO-220 | 8 (0.9) | 0.50 |
| 0.19 (4.8) stud x 0.44 (11.2) hex | 15 (1.7) | 0.16 |
| 0.25 (6.4) stud x 0.69 (17.5) hex | 30 (3.39) | 0.10 |
| 0.38 (9.7) stud x 1.06 (26.9) hex | 75 (8.47) | 0.07 |
| 0.50 (12.7) stud x 1.06 (26.9) hex | 125 (14.12) | 0.07 |
| 0.75 (19.1) stud x 1.25 (31.8) hex | 600 (67.79) | 0.052 |

| 120 SERIES - THERMAL JOINT COMPOUND | |
|-------------------------------------|-------------------------------|
| Characteristic | Description |
| Volume Resistivity | 5 X 10e 14 ohm/cm |
| Dielectric Strength | 225 volts/mil |
| Specific Gravity | 2.1 min. |
| Thermal Conductivity @ WC | 0.735 W/(m)(K) |
| | 5.1 (Btu) (in.)/(hr)(ft²)(°F) |
| Thermal Resistivity (P) | 56 (°C)(in.)/watt |
| Bleed, % after 24 hrs @ 200°C | 0.5 |
| Evaporation, % after 24 hrs @ 200°C | 0.5 |
| Color | opaque white |
| Shelf life | 5 years |
| Operating Temperature Range (°C) | -40/+200 |

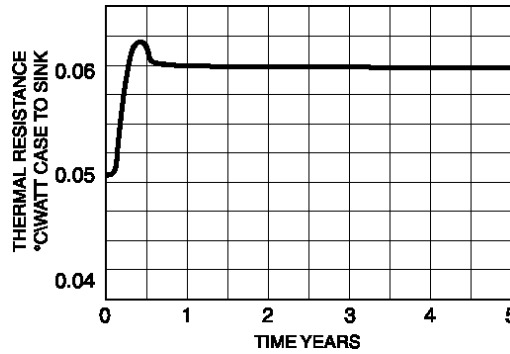

| 120 SERIES - ORDER GUIDE | |
|--------------------------|---------------------|
| Series - P/N | Container Size |
| 120-SA ▲ | 4 gram plastic pak |
| 120-2 ▲ | 2 oz (0.06 kg) jar |
| 120-5 ▲ | 5 oz (0.14 kg) tube |
| 120-8 ▲ | 8 oz (0.23 kg) jar |
| 120-80 ▲ | 5 lb (2.27 kg) can |
| 120-320 | 20 lb (9.08 kg) can |

126 SERIES



The **126 Series** is a nontoxic, synthetic, ester-based (nonsilicone) Thermal Joint Compound with metal oxide fillers designed to enhance thermal performance characteristics of plastic and metal package devices exceeding that of silicone-based compounds. Solved are problems associated with contamination of wave solder baths and migration of silicone-based products.

Shelf life: 5 years.

| 126 SERIES THERMAL JOINT COMPOUND | |
|---|-------------------------------------|
| Characteristics | Description |
| Appearance | Smooth, white homogeneous paste |
| Solids Content, wt % | 65% min |
| Thermal Conductivity at 36°C = 4.8 (Btu)(in.)/(hr) (ft²) (°F) | 19.0 X 10e 4 cal/sec cm °C, min |
| Interface Thermal Resistance | 0.043°C/W TO-3 at 0.0008 thick film |
| Bleed, 24 hrs at 200°C, wt% | 0.09% max |
| Evaporation, 24 hrs at 200°C, wt% | 0.6 max |
| Volume Resistivity | 2.3 x 10e 12 ohms/cm |
| Dielectric Strength | 200 volts/mil |
| Specific Gravity @ 60°F | 2.93 (gm/cc) |
| Penetration | 280 to 320 |
| Operating Range | -40°C to 200°C |

| 126 SERIES - ORDER GUIDE | |
|--------------------------|------------------------|
| Series - P/N | Container Size |
| 126-2 ▲ | 2 oz (0.6 kg) jar |
| 126-4 | 4 oz (0.11 kg) tube |
| 126-4S | 4 oz (0.11 kg) syringe |
| 126-5LB | 5 lb (2.27 kg) can |

THERMAL COMPOUNDS, ADHESIVES AND INTERFACE MATERIALS

DeltaBond™ 152



DeltaBond™ 152 adhesive is ideal for general cementing; thermally bonding semiconductors and components to chassis or heat sinks, while electrically isolating one from the other; fabricating heat sinks or thermal links; and for all permanent bonding of assemblies which require high thermally conductive interfaces. It produces a rigid, high strength bond to most materials when cured. DeltaBond™ 152 is available in bi-packs, kits, and quarts. Order one bottle of hardener A-4 or B-4 per one quart of DeltaBond™ 152 separately. Shelf life: 152KA 1 year, all others 2 years.

| DELTABOND™152 | | |
|--|----------------------------|------------|
| Characteristics | Hardener Type | |
| Typical Properties Fully Cured | A4 | B-4 |
| Thermal conductivity - W/(m) (°K) | 0.836 | 0.908 |
| (Btu) (in.)/(hr) (ft²) (°F) | 5.8 | 6.3 |
| Thermal resistivity - (°C) (in.)/watt | 47 | 42 |
| Bond shear strength 77°F | 2,900 | 2,300 |
| 1 in. overlap - psi 125°F | 2,200 | 2,000 |
| etched aluminum to etched aluminum 212°F | 400 | 800 |
| Heat distortion point - °F | 130 | 225 |
| Minimum dielectric strength, v/mil, 0.125 in. sample | 400 | 400 |
| Max operation temp - °C | Continuous Intermittent | 65 150 |
| | | 100 190 |

| DELTABOND™152 | | |
|--|---|---------------|
| Characteristics | Mixing Proportions and Working Properties | |
| | A-4 | B4 |
| Parts of hardener per 100 parts of resin by weight | 7.5 | 3.5 |
| *Working Time - at 77°F | 45 min | 30 min |
| †Initial cure time 77°F | 8 hrs | 6 hrs |
| 150°F | 45 min | 30 min |
| 250°F | 20 min | 15 min |
| ‡Post-cure time at a temp in °F | 4 hrs @200°F | 4 hrs @ 200°F |
| ‡Alternate room temp. aging time at 77°F | 4 days | 4 days |
| Working consistency (77°F) | viscous liquid | paste |
| Working viscosity (77°F) cps | 25,000 | — |

| Model Number | DELTABOND™152 | | |
|----------------|-------------------------------------|--|---|
| | Ordering Guide - Resin and Hardener | | |
| | Resin | | Hardener |
| | Part No. | Container | Part Number |
| DeltaBond™ 152 | 152-1A 152-1B 152-KA 152-Q | Bi-Pack (1 oz) Bi-Pack (1 oz) Kit (7 oz Resin, 0.5 oz Hardener) 1 quart (4 lbs) | Included in PIN 152-1 A ("A-4") Type Included in P/N 152-1 B ("B-4") Type Included in P/N 152-KA A-4 (0.316 lb), B-4 (0.14 lb), (order 1 only) |

All hardener part numbers A-4, B-4

NOTES:

* Since the hardener/resin reaction is exothermic, it is important that batch size be matched to hardener speed. Working times given are for approximate batch sizes: A—200 gms, B—200 gms. Larger batch sizes will greatly reduce working time.

** For optimum electrical properties, dry parts for 15 minutes at 150°F (65°C) or 30 minutes at 75°F (24°C) to slowly evaporate the thinner and then final cure for 4 hours at 275°F (135°C).

† After initial cure, material may be handled, removed from fixture, etc., but has not yet achieved full properties and should be room temperature aged or post-cured as shown to achieve full physical and electrical properties.

‡ After initial cure, material may be brought to full physical and electrical properties during post-cure or may be room temperature aged for charted length of time to achieve same full properties.

The information contained herein is based on data believed to be reliable but we do not assume responsibility for accuracy. All such information is used at the customer's own risk, conditions of use being beyond our control.

THERMAL INTERFACE MATERIAL DATA FOR T-SERIES AND S-SERIES

T-Series Thermal Tapes come double-sided, and can be attached at the factory. Clips or mechanical fasteners are not required when thermal tapes are used. Not to be used for electrical isolation.

| Material | Thermal Resistivity Degc in. Watt | Thickness | Description | Manufacturer Reference |
|----------|-----------------------------------|-----------|--------------|--------------------------------|
| T-1 | 79 | 0.006 | Thermal Tape | Chomerics T-405 |
| T-2 | 55 | 0.0045 | Thermal Tape | Adhesives Research Arclad 8223 |
| T-3 | 28 | 0.009 | Thermal Tape | Chomerics T-412 |
| T-4 | 157 | 0.007 | Thermal Tape | Chomerics T-410 |

S-Series Thermal Interface Material come double-sided, and are applied at the factory only. They fill gaps due to surface roughness and flatness either under pressure or at temperature. These products also require mechanical fasteners. Not to be used for electrical isolation.

| Material | Thermal Resistivity Degc in. Watt | Thickness | Description | Manufacturer Reference |
|----------|-----------------------------------|-----------|-------------------|----------------------------------|
| S-3 | 25 | 0.005 | Thermal Interface | Bergquist Q-pad 3 |
| S-4 | 11 | 0.005 | Thermal Interface | Bergquist softface |
| S-5 | 15 | 0.0055 | Thermal Interface | Chomerics T-710 |
| S-6 | 19 | 0.0052 | Phase-Change Pad | Chomerics T-443 |
| S-7 | 6 | 0.003 | Tape a/Alum. Sub. | Power Devices AI-S (Thermstrate) |
| S-8 | 25 | 0.0065 | Phase-Change Pad | Bergquist 2004 |

THERMAL COMPOUNDS, ADHESIVES AND INTERFACE MATERIALS
DeltaCast™ 153

DeltaCast™ 153 is a pourable casting resin having thermal expansion characteristics similar to aluminum and copper allowing assemblies to operate over a very wide temperature range. Ideal for encapsulating components and assemblies, this series' major advantages and uses include potted systems (virtually indestructible), protecting components and systems from moisture and contaminants, securing proprietary circuitry, mechanical support of devices, removal of heat from hot components and the assembly equalizing temperatures, and high voltage isolation. DeltaCast™ 153 is available in quarts and gallons. Order one bottle of hardener A4 or B-4 per one quart of DeltaCast™ 153 separately. Shelf life: 2 years.

| DELTACAST™153 | | |
|--|---------------|-------|
| Characteristics | Hardener Type | |
| | A4 | B-4 |
| Typical Properties Fully Cured | | |
| Thermal conductivity - W/(m) (°K) | 0.836 | 0.908 |
| (Btu) (in.)/(hr) (ft²) (°F) | 5.8 | 6.3 |
| Thermal resistivity - (°C) (in.)watt | 47 | 42 |
| Bond shear strength 77°F | 2,500 | 1,900 |
| 1 in. overlap - psi 125°F | — | — |
| etched aluminum to etched aluminum 212°F | — | — |
| Heat distortion point - °F | 130 | 225 |
| Minimum dielectric strength, v/mil, 0.125 in. sample | 400 | 400 |
| Max operation temp - °C | 65 | 150 |
| Continuous Intermittent | 100 | 190 |

| DELTACAST™153 | | |
|--|--------------|----------------|
| Mixing Proportions and Working Properties | | |
| Characteristics | A-4 | B4 |
| Parts of hardener per 100 parts of resin by weight | 7.5 | 3.5 |
| *Working Time - at 77°F | 45 min | 30 min |
| † Initial cure time 77°F | 8 hrs | 6 hrs |
| 150°F | 45 min | 30 min |
| 250°F | 20 min | 15 min |
| ‡Post-cure time at a temp in °F | 4 hrs @200°F | 4 hrs @ 200°F |
| ‡Alternate room temp. aging time at 77°F | 4 days | 4 days |
| Working consistency (77°F) | heavy liquid | viscous liquid |
| Working viscosity (77°F) cps | 10,000 | 30,000 |

| Model Number | DELTACAST™153 | | |
|----------------|-------------------------------------|-----------------|---|
| | Ordering Guide - Resin and Hardener | | |
| | Resin | | Hardener |
| | Part No. | Container | Part Number |
| DeltaCast™ 153 | 153-Q | 1 quart (4 lbs) | A-4 (0.316 lb), B-4 (0.14 lb), (order 1 only) |

All hardener part numbers A-4, B-4

DeltaBond™ 154

DeltaBond™ 154 is a medium viscosity, aluminum-filled resin with the best thermal conductivity of this series. It is, however, neither a good electrical insulator nor conductor. Its principal application is that of a good thermal mechanical adhesive for applications such as bonding fins to base plates or structural mounting blocks or brackets to heat sinks. Shelf life: 2 years.

| DELTABOND™154 | | |
|--|---------------|-------|
| Characteristics | Hardener Type | |
| | A4 | B-4 |
| Typical Properties Fully Cured | | |
| Thermal conductivity - W/(m) (°K) | 1.053 | 1.154 |
| (Btu) (in.)/(hr) (ft²) (°F) | 7.3 | 8.0 |
| Thermal resistivity - (°C) (in.)watt | 37 | 34 |
| Bond shear strength 77°F | 3,000 | 2,400 |
| 1 in. overlap - psi 125°F | 2,300 | 2,100 |
| etched aluminum to etched aluminum 212°F | 500 | 800 |
| Heat distortion point - °F | 130 | 225 |
| Minimum dielectric strength, v/mil, 0.125 in. sample | NA* | NA* |
| Max operation temp - °C | 65 | 150 |
| Continuous Intermittent | 100 | 190 |

| DELTABOND™154 | | |
|--|----------------|---------------|
| Mixing Proportions and Working Properties | | |
| Characteristics | A-4 | B4 |
| Parts of hardener per 100 parts of resin by weight | 11.0 | 4.5 |
| *Working Time - at 77°F | 45 min | 30 min |
| † Initial cure time 77°F | 8 hrs | 6 hrs |
| 150°F | 45 min | 30 min |
| 250°F | 20 min | 15 min |
| ‡Post-cure time at a temp in °F | 4 hrs @200°F | 4 hrs @ 200°F |
| ‡Alternate room temp. aging time at 77°F | 4 days | 4 days |
| Working consistency (77°F) | viscous liquid | paste |
| Working viscosity (77°F) cps | 25,000 | — |

| Model Number | DELTABOND™154 | | |
|----------------|-------------------------------------|-------------------|---|
| | Ordering Guide - Resin and Hardener | | |
| | Resin | | Hardener |
| | Part No. | Container | Part Number |
| DeltaBond™ 154 | 154-Q | 1 quart (2.5 lbs) | A-4 (0.316 lb), B-4 (0.14 lb), (order 1 only) |

All hardener part numbers A-4, B-4

THERMAL COMPOUNDS, ADHESIVES AND INTERFACE MATERIALS

DeltaBond™ 155



DeltaBond™ 155 is an epoxy adhesive formulated for use within the semiconductor industry. An easy to mix spread thixotropic paste, it offers high heat transfer, low shrinkage, and a coefficient of thermal expansion comparable to that of copper and aluminum. This adhesive is principally used to form thermally conductive joints in fabricated heat sinks and between heat sinks and power devices. When used to bond semiconductors to heat sinks, it also serves as an electrical insulator. Its strong bond to a wide variety of substrates resists severe temperature cycling. **DeltaBond™ 155** is only available in kit size. Simply squeeze out equal lengths and mix to uniform color. Shelf life: 1 year.

| DELATABOND™155 | | |
|---|--------------------------------|--|
| Characteristics | Hardener Type DeltaBond™155 | |
| Typical Properties Fully Cured | | |
| Thermal conductivity - W/(m) (°K) | 0.836 | |
| (Btu) (in.)/(hr) (ft²) (°F) | 5.8 | |
| Thermal resistivity - (°C) (in.)watt | 47 | |
| Bond shear strength 77°F | 2,600 | |
| 1 in. overlap - psi 125°F | — | |
| etched aluminum to etched aluminum 212°F | — | |
| Heat distortion point - °F | 130 | |
| Minimum dielectric strength, v/mil, 0.125 in. sample | 400 | |
| Max operation Continuous temp - °C Intermittent | 65 100 | |

| DELATABOND™155 | |
|---|---------------|
| Mixing Proportions and Working Properties | |
| Parts of hardener per 100 parts of resin | by volume 100 |
| *Working Time - at 77°F | 90 min |
| †Initial cure time 77°F | 8 hrs |
| 150°F | 45 min |
| 250°F | 20 min |
| ‡Post-cure time at a temp in °F | 4 hrs @ 200°F |
| ‡Alternate room temp. aging time at 77°F | 4 days |
| Working consistency (77°F) | paste |
| Working viscosity (77°F) cps | paste |

| DELATABOND™154 | | | |
|-----------------|-------------------------------------|---------------------------------|---------------------|
| Model Number | Ordering Guide - Resin and Hardener | | |
| | Resin | | Hardener |
| | Part No. | Container | Part Number |
| DeltaBond™ 155 | 155 | Kit (3 oz resin, 3 oz hardener) | Included in P/N 155 |

DeltaBond™ 156



DeltaBond™ 156 Thermally Conductive Adhesive is a modified acrylic adhesive designed for permanent mounting on components where heat must be effectively transmitted. Recommended for electromechanical assemblies to bond components and dissipate heat, it replaces mechanical fasteners and compressible pads, silicone grease, and epoxies; eliminates air entrapment, and other variables related to epoxy mixing. This soft paste requires no mixing and flows easily to allow thin bond lines. Primer activated, cure begins upon assembly. DeltaBond™ Activator fixtures at room temperature in less than 5 minutes. Full strength is developed in 4 to 12 hours and fillets become dry to the touch in 24 hours. It is not recommended to use this durable adhesive without the use of DeltaBond™ Activator. **DeltaBond™ 156** is available in kit size; order 156-K (25 ml Syringe and Activator Kit). Shelf life: 1 year.

| DELATABOND™156 | | |
|--|--|-------|
| Characteristics | Description | |
| Typical Properties Fully Cured | | |
| Test | Results | ASTM |
| Temperature Range | -65 to 300°F (-54 to 149°C) 300°F to (177°C) Intermittent | |
| Tensile Strength, at break | 2360 psi | D638 |
| Modulus | 233,000 psi | D638 |
| Elongation, at break | 7.75% | D638 |
| Outgassing | 2.5% TLM 0.05% CVCm | E595 |
| Coefficient of Thermal Expansion | 7.1 x 10e -4 (cm/cm°C) | |
| Tensile Shear | 2500psi | D1002 |
| Thermal Conductivity, K (absolute at 86°F (30°C)) | 3.47 Btu x in./hr ft² °F (0.50 W/m °C) | |

Note: The absolute thermal conductivity test was developed specifically for measuring thermal properties of thin film adhesive bonds.

| DELATABOND™156 | | |
|----------------------------------|----------------------|------|
| Typical Electrical Properties | | |
| Test | Results | ASTM |
| Dielectric Strength | 220 volts/mil | D149 |
| Dielectric Constant, 77°F (25°C) | | D150 |
| 100 Hz | 14.92 | |
| 1000 Hz | 14.26 | |
| 1MM Hz | 12.34 | |
| Dissipaton Factor, 77°F (25°C) | | D150 |
| 100 Hz | 0.05 | |
| 1000 Hz | 0.03 | |
| 1MM Hz | 0.06 | |
| Volume Resistivity | 5.2x10e 11 (ohms-cm) | D257 |
| Surface Resistivity | 8.6 x 10e 13 (ohms) | D257 |

Note: DeltaBond™ Thermally Conductive Adhesive-High Strength contains a metallic filler which, in certain applications, may have an effect on electrical properties. Therefore, test each particular application to ensure that electrical properties are as required.

| Model Number | DELATABOND™156 | | |
|-----------------|-------------------------------------|---|---|
| | Ordering Guide - Resin and Hardener | | |
| | Resin | | Hardener |
| | Part No. | Container | Part Number |
| DeltaBond™ 156 | 156-K | Resin Kit Hardener Syringe - 0.85 fl oz - 25 ml - 2 oz net/0.44 oz fl contents bottle -12ml | Included in kit hardener with brush applicator - 4.2 oz total wt/kt |

* Since the hardener/resin reaction is exothermic, it is important that batch size be matched to hardener speed. Working times given are for approximate batch sizes: A—200 gms, B—200 gms. Larger batch sizes will greatly reduce working time.

† After initial cure, material may be handled, removed from fixture, etc., but has not yet achieved full properties and should be room temperature aged or post-cured as shown to achieve full physical and electrical properties.

‡ After initial cure, material may be brought to full physical and electrical properties during post-cure or may be room temperature aged for charted length of time to achieve same full properties.

The information contained herein is based on data believed to be reliable but we do not assume responsibility for accuracy. All such information is used at the customer's own risk, conditions of use being beyond our control.

THERMAL COMPOUNDS, ADHESIVES AND INTERFACE MATERIALS



173/174 SERIES
175 SERIES

DeltaPads™ Thermally Conductive Insulators
Greaseless Thermally Conductive Kapton® Reinforced Insulators

TO-3, TO-66, TO-220, DO-4, DO-5 SHEET

The 173, 174, and 175 Series are highly efficient thermally conductive insulators designed for semi-conductor interface to heat sinks. Their properties eliminate messy concerns associated with thermal greases.

| Characteristics | DeltaPads™ 173-7 Series | DeltaPads™ 173-9 Series | DeltaPads™ 174-9 Series | Kapton® 175-6 Series | Test Method |
|--|----------------------------|----------------------------|----------------------------|-------------------------|-------------|
| Material Thickness | 0.007 in. | 0.009 in. | 0.009 in. | 0.006 in. | Micrometer |
| Color | Gray | Gray | Tan | Gray | Visual |
| Tear Strength, lb/in. Typical | 100 | 100 | 100 | 100 | ASTM 0624 |
| Volume Resistivity, megohm-cm, Minimum Normal | 1.0 x 10e 9 | 1.0 x 10e 9 | 1.0 x 10e 13 | 1 x 10e 13 | ASTM D257 |
| Breakdown Voltage, Minimum | 4,000 | 5,000 | 5,000 | 6,000 | ASTM 0149 |
| Dielectric Constant at 60 Hz and 100 V Maximum | 2.70 | 2.40 | 2.50 | 5.5 @ 1,000 Hz | ASTM D 150 |
| Continuous Use Temperature, °C | -60/+200 | -60/+200 | -60/+200 | -60/+200 | - |
| Thermal Conductivity, cal/cm sec. °C, Minimum | 3 x 10e -3 | 3 x 10e -3 | 1 x 10e -2 | 1.2 x 10e -3 | - |
| Thermal Resistance (TO-3), 1 in.² °C/W | 0.33 | 0.50 | 0.25 | 0.40 | - |
| Recommended Mounting Pressure, lb/in.² | 350/550 | 350/550 | 350/550 | 350/550 | Formula* |

$$*P \text{ (pressure in psi)} = \frac{T \text{ (torque [in.-lb]} \times N \text{ (number of fasteners)}}{0.2 \times D \text{ (Thread Dia)} \times A \text{ (contact surface area square inches)}}$$

| 173-7 Series | | 173-9 Series | 174-9 Series | 175-6 Series | Mechanical Dimensions in. (mm) | | | | |
|--------------|------------------|--------------|--------------|--------------|-----------------------------------|----------------|-------------|----------------|------------|
| No Adhesive | Adhesive Backing | No Adhesive | No Adhesive | Greaseless | A | B | C | D | Case Style |
| 173-7-210P | - | 173-9-210P | 174-9-210P | 175-6-210P | 0.687 (17.4) | 0.562 (14.3) | 0.218 (5.5) | 0.125 (3.2) | TO-220 |
| 173-7-220P▲ | - | 173-9-220P▲ | 174-9-220P | 175-6-220P | 0.710 (18-0) | 0.500 (12.7) | 0.160 (4.1) | 0.141 (3.6) | TO-220 |
| 173-7-230P | - | 173-9-230P | 174-9-230P | 175-6-230P | 0.750 (19.1) | 0.500 (12.7) | 0.187 (4.8) | 0.125 (3.2) | TO-220 |
| 173-7-240P | 173-7-240A | 173-9-240P | 174-9-240P | 175-6-240P▲ | 0.750 (19.1) | 0.500 (12.7) | 0.187 (4.8) | 0.147 (3.7) | TO-220 |
| 173-7-250P | - | 173-9-250P | 174-9-250P | 175-6-250P | 0.865 (22.0) | 0.650 (16.5) | 0.205 (5.2) | 0.140 (3.6) | TO-220 |
| - | - | - | - | 175-6-260P | 1.000 (25.4) | 0.750 (19.1) | 0.320 (8.1) | 0.141 (3.6) | TO-220 |
| - | - | 173-9-280P | - | 175-6-280P | 0.860 (21.8) | 0.740 (18.8) | 0.200 (5.1) | 0.160 (4.1) | TO-220 |
| 173-7-290P | - | 173-9-290P | - | - | 0.855 (21.7) | 0.630 (16.0) | 0.230 (5.8) | 0.093 (2.4) | TO-220 |
| 173-7-310P | - | 173-9-310P | 174-9-310P | 175-6-310P▲ | 1.593 (40.5) | 1.100 (27.9) | 0.156 (4.0) | 0.062 (1.6) | TO-3 |
| 173-7-320P | 173-7-320A | 173-9-320P | 174-9-320P | 175-6-320P | 1.650 (41.9) | 1.140 (29.0) | 0.122 (3.1) | 0.062 (1.6) | TO-3 |
| 173-7-330P | - | 173-9-330P | 174-9-330P | 175-6-330P | 1.650 (41.9) | 1.140 (29.0) | 0.140 (3.6) | 0.093 (3.4) | TO-3 |
| 173-7-340P | - | 173-9-340P | - | 175-6-340P | 1.780 (45.2) | 1.250 (31.8) | 0.140 (3.6) | 0.093 (3.4) | TO-3 |
| 173-7-350P | - | 173-9-350P | - | - | 1.563 (39.7) | 1.050 (26.7) | 0.140 (3.6) | 0.080 (2.0) | TO-3 |
| 173-7-410P | - | 173-9-410P | 174-9-410P | 175-6-410P | 0.625 (15.9)OD | 0.200 (5.1)ID | N/A | N/A | DO-4, DO-5 |
| 173-7-510P | - | 173-9-510P | 174-9-510P | 175-6-510P | 0.800 (20.3)OD | 0.260 (6.6)ID | N/A | N/A | DO-4, DO-5 |
| 173-7-520P | - | 173-9-520P | 174-9-520P | 175-6-520P | 1.000 (25.4)OD | 0.260 (6.6)ID | N/A | N/A | DO-4, DO-5 |
| 173-7-610P | - | 173-9-610P | 174-9-610P | 175-6-610P | 1.312 (33.3) | 0.762 (19.4) | 0.140 (3.6) | 0.062(1.6) | TO-66 |
| 173-7-710P | - | 173-9-710P | - | 175-6-710P | 0.360 (9.14)OD | 0.200 (5.1)ID | 0.040 (1.0) | - | TO-5 |
| - | - | 173-9-810P | - | 175-6-810P | 2.000 (50.8) | 0.750 (19.1) | 0.187 (4.3) | 0.125 (3.8)DIA | TO-220 |
| - | - | 173-9-820P | - | 175-6-820P | 4.000 (101.6) | 0.750 (19.1) | 0.187 (4.3) | 0.125 (3.8)DIA | TO-220 |
| - | - | 173-9-910P | - | - | 1.000 (25.4) | 0.500 (12.7) | 0.200 (5.1) | 0.141 (3.6) | TO-66 |
| 173-7-66P | 173-7-66A | 173-9-66P | 174-9-66P | 175-6-66P | 6.000 (152.4) | 6.000 (152.4) | N/A | N/A | SHEET |
| 173-7-1212P | 173-7-1212A | 173-9-1212P | 174-9-1212P | - | 12.000 (304.8) | 12.000 (304.8) | N/A | N/A | SHEET |
| - | - | - | - | 175-6-1311P | 13.000 (330.2) | 11.000 (279.4) | N/A | N/A | SHEET |

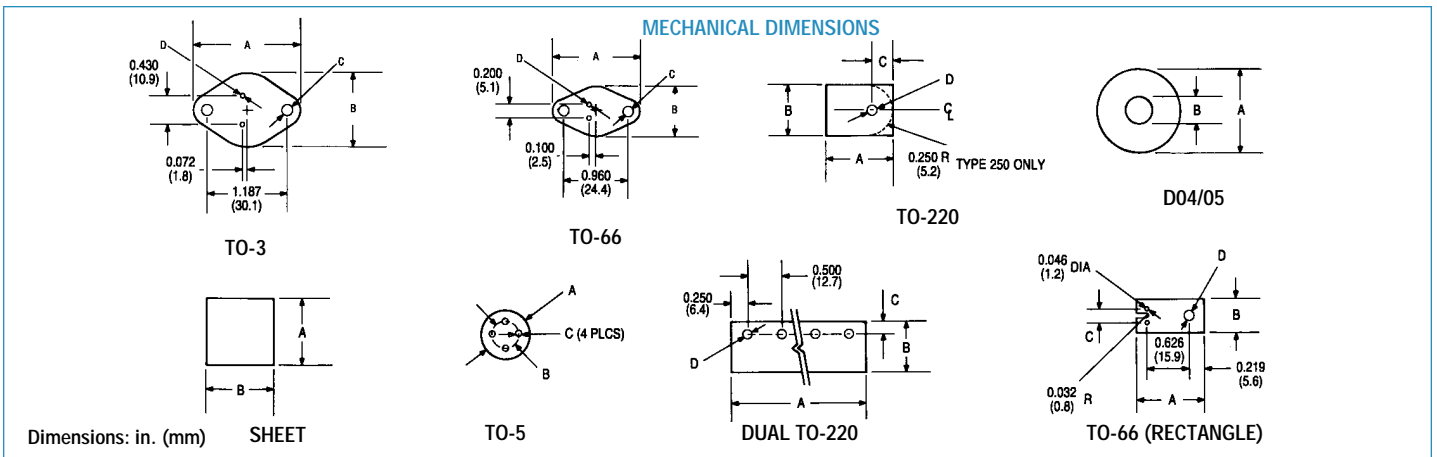

X-ON Electronics

Largest Supplier of Electrical and Electronic Components

Click to view similar products for [Thermal Interface Products](#) category:

Click to view products by [Wakefield](#) manufacturer:

Other Similar products are found below :

[63072-2-4013](#) [64442-1-7612](#) [FGN80-2](#) [PFM-172-60](#) [95778-1-5171](#) [A-40](#) [ACDIN4001-01-S](#) [APA502-80-001](#) [188761F00000G](#) [95779-1-5171](#) [9601-7](#) [9614-2-4013](#) [189790F00000](#) [189951F00000G](#) [2103-4-7320](#) [CN9565-000](#) [31570-2-4013](#) [LZ24-1](#) [4103G](#) [450-20-0025](#) [5300AC](#) [1.500G](#) [53-77-13ACG](#) [450-20-0017](#) [4949G](#) [08121](#) [08133](#) [08151](#) [08188](#) [08196](#) [10637-4-1040](#) [54476-2-4013](#) [71883-2-4053](#) [188651F00000G](#) [64445-1-7612](#) [66786-4-7320](#) [TP0001](#) [4952G](#) [4860](#) [450-20-0148](#) [88601-2-2929](#) [SC80-W2](#) [09450-M45](#) [09362-M45](#) [V6516C](#) [A17713-05](#) [A17690-06](#) [A17690-10](#) [A17690-05](#) [A17690-03](#) [A17775-05](#)