

BOARD LEVEL POWER SEMICONDUCTOR HEAT SINKS

<i>Board Level Power Semiconductor Heat Sinks</i>	46-76
<i>219 Series Heat Sinks for TO-263 Devices</i>	48-49
<i>Board Level Heat Sinks for TO-220, TO-218 & Multiwatt™ Components</i>	59-61
<i>Universal 678 Series Vertical Heat Sink for Power Devices</i>	77
<i>One Heat Sink for all Packages</i>	78
<i>Mountain Series Heat Sinks for TO-264, TO-247 Devices</i>	79-80
<i>omniKlip™ Series Heat Sink w/ Clip(s) for TO-Devices</i>	81-83
<i>Additional Configurations</i>	84

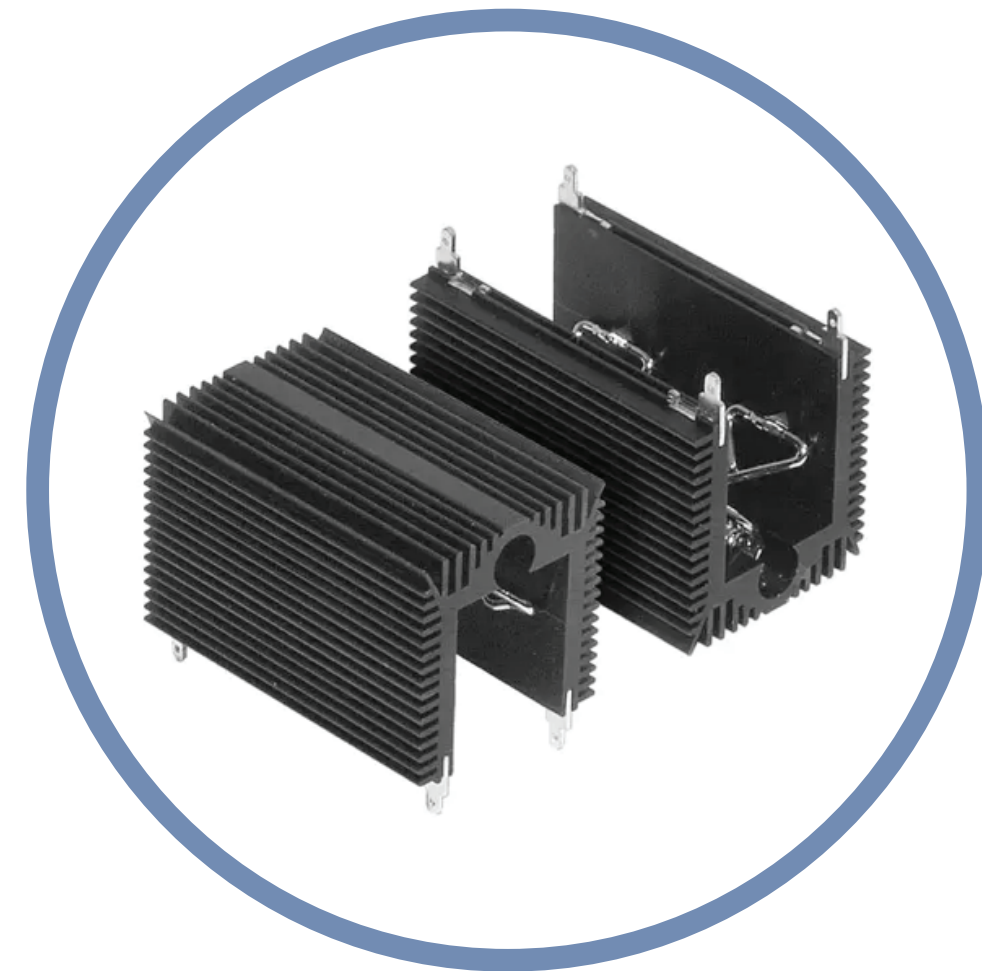

A wide variety of heat dissipators with various attachment mechanisms for surface mount and thru-hole power semiconductors packaged in industry standard plastic, ceramic, and metal cases such as D2Pak, TO-220, TO-3 to TO-247, DO-4 to DO-11, multiwatt, hex-type, and stud mount devices.

BOARD LEVEL POWER SEMICONDUCTOR HEAT SINKS

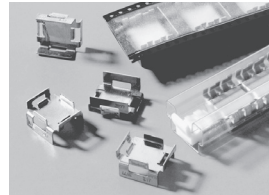

217 SERIES SURFACE MOUNT HEAT SINKS

D2PAK; TO-220; SOT-223; SOL-20

Compatible with surface mount technology (SMT) automated production techniques for ease of assembly and a variety of soldering methods, these heat sinks allow greater packaging densities and reduction in PC-board area, increasing the power dissipation of surface mount devices (SMDs) while maintaining and improving manufacturers' component thermal specifications.

FEATURES AND BENEFITS

- No interface material is needed
- Copper with matte tin plating for improved solderability and assembly
- Both the component and the heat sink are installed on the PC-board utilizing standard SMT assembly equipment for "Tape & Reel" and "Tube" formats
- EIA standards and ESD protection are specified
- Can be used with water soluble or no clean SMT solder creams or other pastes

Footprint Standard P/N	Height Above PC Board in. (mm)	Dimensions in. (mm)	Package Format	Package Quantity	Thermal Performance at Typical Load	
					Natural Convection	Forced Convection
217-36CTE6	.360 (9.1)	.600 (15.2) x .740 (18.8)	Bulk	1	55°C @ 1W	16.0°C/W @ 200 LFM
217-36CTTE6	.360 (9.1)	.600 (15.2) x .740 (18.8)	Tube	20	55°C @ 1W	16.0°C/W @ 200 LFM
217-36CTRE6	.360 (9.1)	.600 (15.2) x .740 (18.8)	Tape & Reel	250	55°C @ 1W	16.0°C/W @ 200 LFM

Material: Copper, Matte Tin Plated

MECHANICAL DIMENSIONS

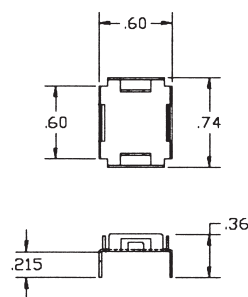

217-36CT6

Dimensions: in.

THERMAL PERFORMANCE
6 LAYER BOARD, D' PAK
125°C LEAD, 40°C AMBIENT

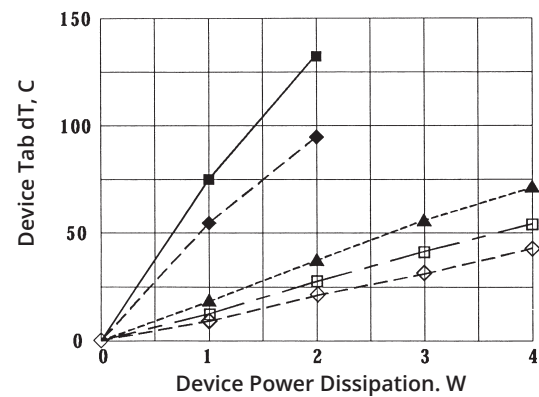

KEY: ■ Device only, NC ◆ Device + HS, NC ▲ Device + HS, 100 lfm
□ Device + HS, 200 lfm ◇ Device + HS, 300 lfm

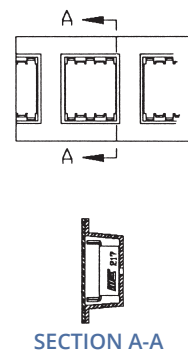

SECTION A-A

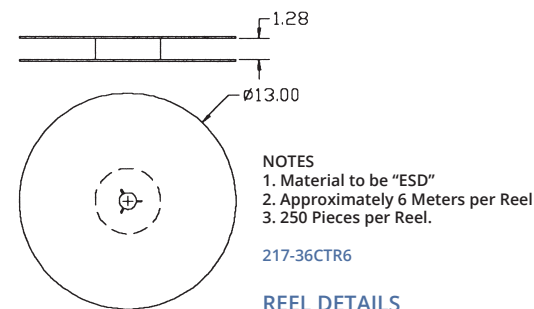

REEL DETAILS

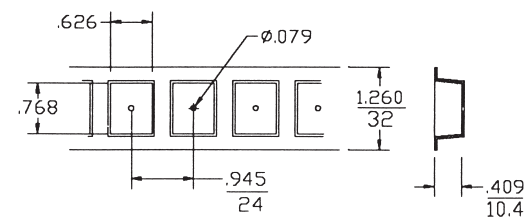

TAPE DETAILS

D2PAK; TO-220; SOL-20

SURFACE MOUNT HEAT SINKS

217 SERIES

MECHANICAL DIMENSIONS

TUBE DETAILS

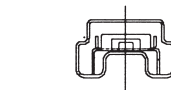
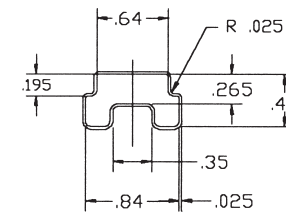

Tube: 16.25 Inches Long, Min. esd Material with Nail Stops
20 Pieces per Tube

217-36CTT6

Dimensions: in.

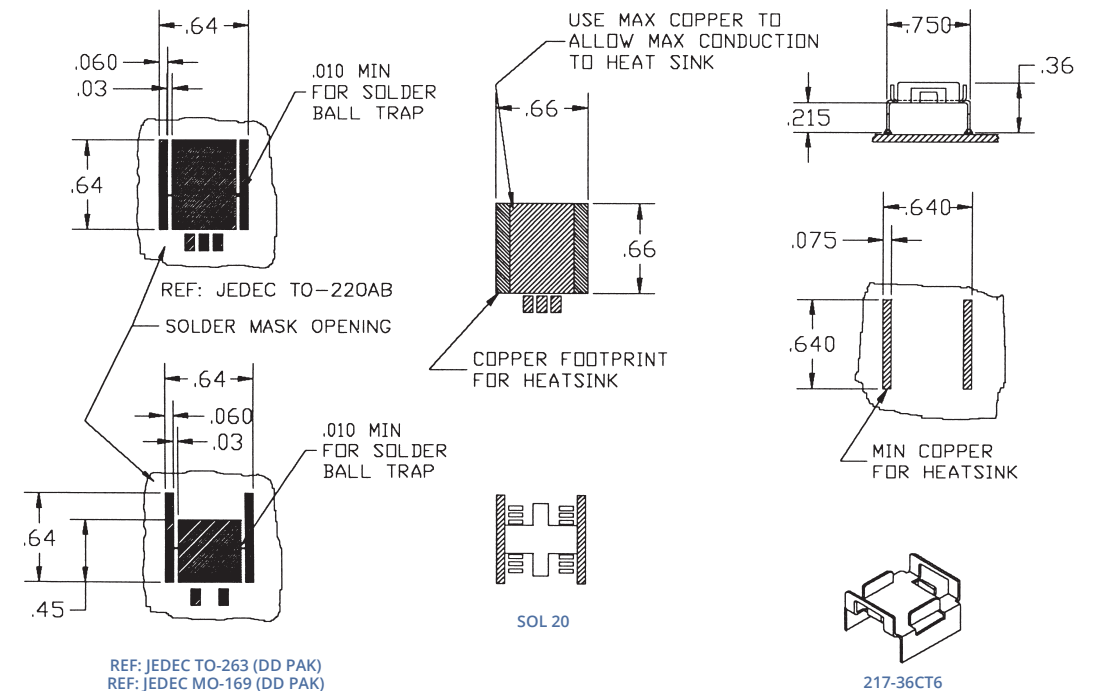

BOARD LAYOUT RECOMMENDATIONS

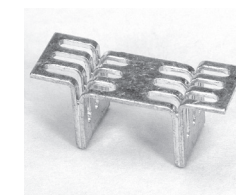

218 SERIES SURFACE MOUNT HEAT SINK

SMT Devices

Standard P/N	Height Above PC Board in. (mm)	Maximum Footprint in. (mm)	Thermal Performance at Typical Load	
			Natural Convection	Forced Convection
218-40CTE3	.40 (10.2)	.90 (22.9) x .315 (8.0)	62°C rise @ 2W	21°C/W @ 200LFM
218-40CTE5	.40 (10.2)	1.03 (26.2) x .50 (12.7)	62°C rise @ 2W	21°C/W @ 200LFM

Material: Copper, Matte Tin Plated

MECHANICAL DIMENSIONS

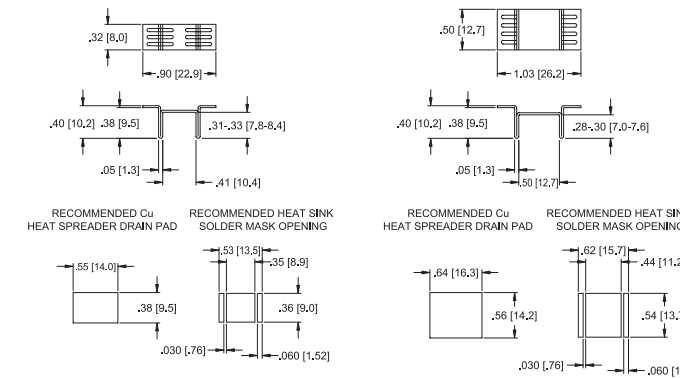

218-40CT3

218-40CT5

NATURAL AND FORCED CONVECTION CHARACTERISTICS

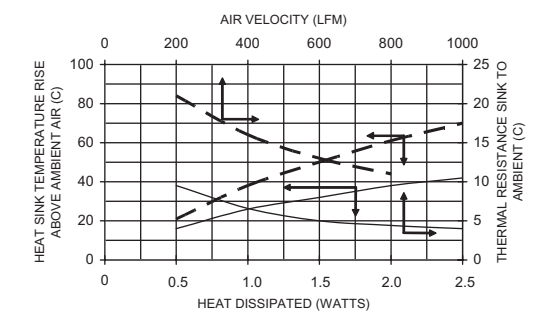

Solid line = 218-40CT5 Dashed Line = 218-40CT3

219 SERIES HEAT SINKS FOR TO-263 DEVICES

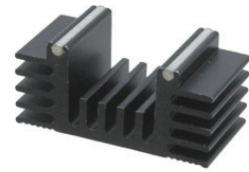

219-263A HEAT SINK FOR TO-263 DEVICES



Innovation in SMT compatible heat sinks to meet the needs of newer higher power SMT semiconductors. The 219 Series heat sinks unique design (Patent Pending) combines the technology of automatically assembling the tin plated solderable wires/rods with that of extruded aluminum anodized heat sink body to configure these SMT heat sinks. Rods/wires named "Rollers" are mated mechanically to the heat sink body by forging to reduce the interface thermal resistance between the drains & heat dissipation body.

FEATURES AND BENEFITS

- Increased thermal performance up to 30% over bright copper heat sinks from improved radiation of the black finish.
- Increased surface areas by 3 times therefore thermal performance up to 300% over the aluminum stamped heat sinks on markets.
- Light weight aluminum construction allows faster pick and place assembly reducing the manufacturing cycle time.
- Radius mounted "Rollers" are designed for maximizing heat transfer from component and to avoid "bottle neck" heat transfer like the Aluminum stamped heat sinks.
- Available in bulk packaging or Tape & Reel.

Part Number	Description	Attachment	Length	Width	Height Off Base (Height Of Fin)	Power Dissipation @ Temperature Rise	Thermal Resistance @ Forced Air Flow	Package Type
219-263A	TO-263 SMD HEAT SINK ANODZD	Solderable Feet	0.500" (12.70mm)	1.020" (25.91mm)	0.480" (12.19mm)	2W @ 30°C	8°C/W @ 500 LFM	Bulk

MECHANICAL DIMENSIONS

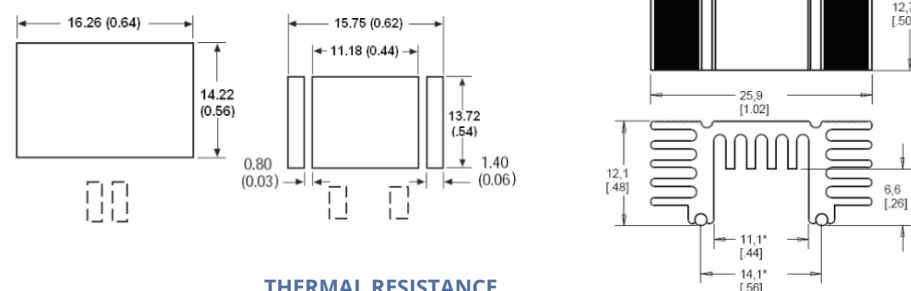

THERMAL RESISTANCE

Air Velocity - Feet Per Minute

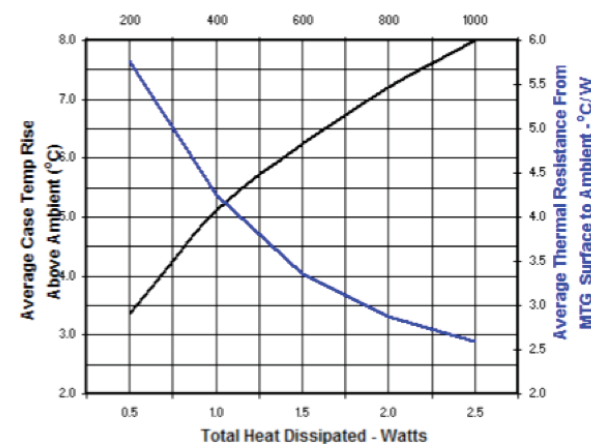

TAPE AND REEL INFORMATION

Reel diameter: 13.00" (330.00mm)
250 pcs. per

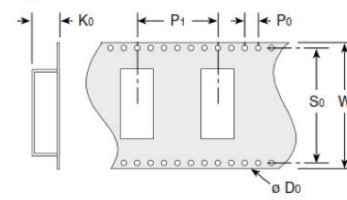

	Style 10	Style 20	Style 30
Do	1.55mm	1.5mm	1.5mm
K0	10.5mm	12.20mm	11.50mm
P0	4mm	4.0mm	4.0mm
P1	24mm	24mm	24.0mm
So	40.4mm	40.4mm	52.4mm
W	44mm	44mm	56mm

TAPE DETAILS



HEAT SINK FOR TO-263 DEVICES 219-263A-TR



Innovation in SMT compatible heat sinks to meet the needs of newer higher power SMT semiconductors. The 219 Series heat sinks unique design (Patent Pending) combines the technology of automatically assembling the tin plated solderable wires/rods with that of extruded aluminum anodized heat sink body to configure these SMT heat sinks. Rods/wires named "Rollers" are mated mechanically to the heat sink body by forging to reduce the interface thermal resistance between the drains & heat dissipation body.

FEATURES AND BENEFITS

- Increased thermal performance up to 30% over bright copper heat sinks from improved radiation of the black finish.
- Increased surface areas by 3 times therefore thermal performance up to 300% over the aluminum stamped heat sinks on markets.
- Light weight aluminum construction allows faster pick and place assembly reducing the manufacturing cycle time.
- Radius mounted "Rollers" are designed for maximizing heat transfer from component and to avoid "bottle neck" heat transfer like the Aluminum stamped heat sinks.
- Available in bulk packaging or Tape & Reel.

Part Number	Description	Attachment	Length	Width	Height Off Base (Height Of Fin)	Power Dissipation @ Temperature Rise	Thermal Resistance @ Forced Air Flow	Package Type
219-263A-TR	TO-263 SMD HEAT SINK ANODZD	Solderable Feet	0.500" (12.70mm)	1.020" (25.91mm)	0.480" (12.19mm)	2W @ 30°C	8°C/W @ 500 LFM	Tape & Reel

MECHANICAL DIMENSIONS

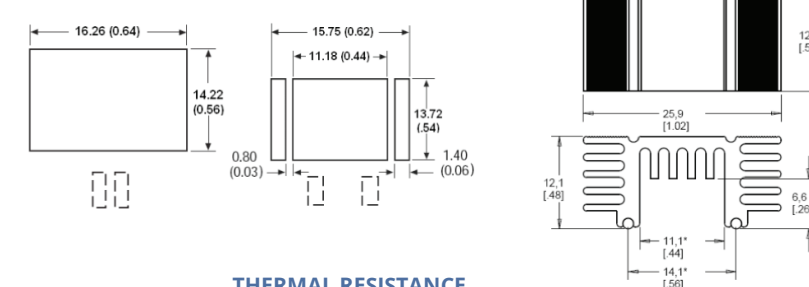

THERMAL RESISTANCE

Air Velocity - Feet Per Minute

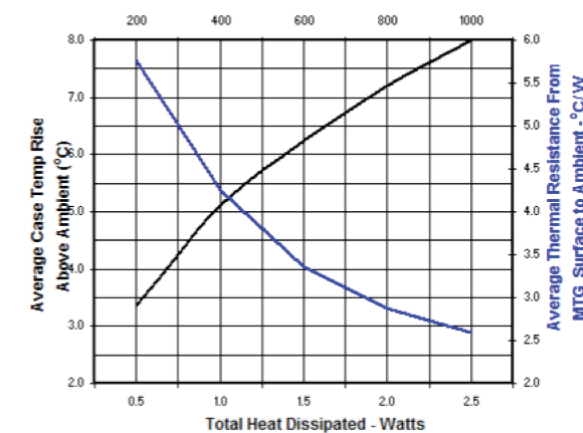

TAPE AND REEL INFORMATION

Reel diameter: 13.00" (330.00mm)
250 pcs. per

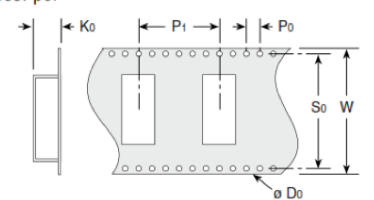

	Style 10	Style 20	Style 30
Do	1.55mm	1.5mm	1.5mm
K0	10.5mm	12.20mm	11.50mm
P0	4mm	4.0mm	4.0mm
P1	24mm	24mm	24.0mm
So	40.4mm	40.4mm	52.4mm
W	44mm	44mm	56mm

BOARD LEVEL POWER SEMICONDUCTOR HEAT SINKS

206 SERIES VERTICAL MOUNT HEAT SINK

TO-220

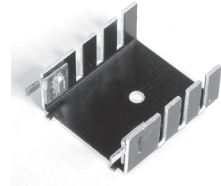

Standard P/N	Height Above PC Board in. (mm)	Maximum Footprint in. (mm)	Thermal Performance at Typical Load	
			Natural Convection	Forced Convection
206-1PABEH	1.18 (30.0)	1.00 (25.4) x .50 (12.7)	56°C rise @ 4W	7.3°C/W @ 200LFM

Material: Aluminum, Black Anodized

MECHANICAL DIMENSIONS

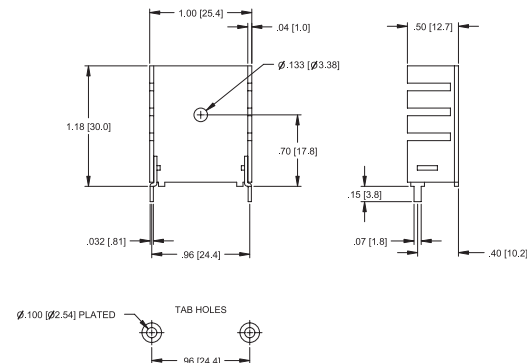

NATURAL AND FORCED CONVECTION CHARACTERISTICS

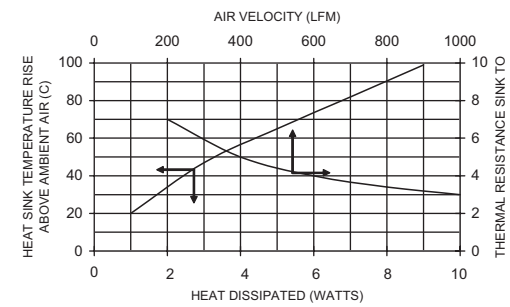

TO-220

HORIZONTAL MOUNT HEAT SINK 241 SERIES

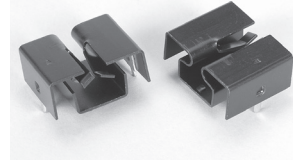

Standard P/N	Height Above PC Board in. (mm)	Maximum Footprint in. (mm)	Thermal Performance at Typical Load	
			Natural Convection	Forced Convection
241-69ABE-03	.39 (9.9)	.86 (21.8) x .69 (17.5)	77°C rise @ 4W	12°C/W @ 200LFM

Material: Aluminum, Black Anodized

MECHANICAL DIMENSIONS

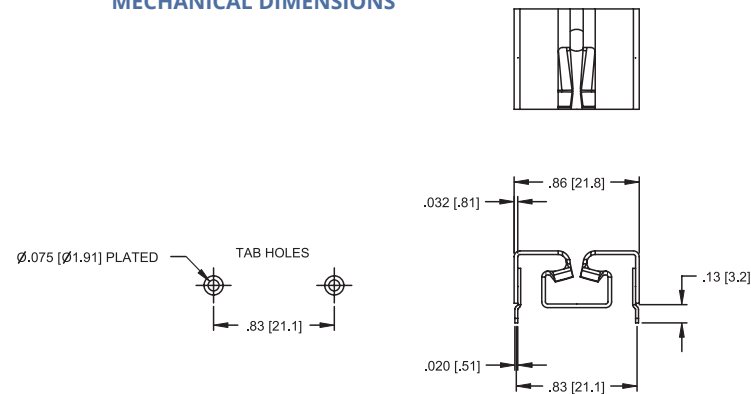

NATURAL AND FORCED CONVECTION CHARACTERISTICS

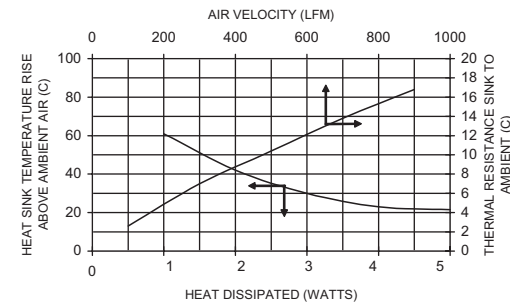

COMPACT, WAVE-SOLDERABLE LOW-PROFILE SELF-LOCKING HEAT SINKS

230 & 234 SERIES

TO-220

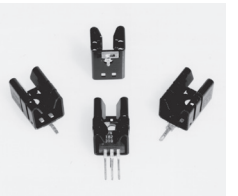

Standard P/N	Height Above PC Board in. (mm)	Footprint Dimensions in. (mm)	Mounting Configuration	Solderable Tab Option	Mounting Style	Thermal Performance at Typical Load	
						Natural Convection	Forced Convection
230-75AB	.750 (19.1)	.570 (14.5) x .500 (12.7)	Vert./Horiz.	No Tab	Clip/Mtg Hole	57°C @ 2W	7.5°C/W @ 400 LFM
230-75ABE-01	.750 (19.1)	.570 (14.5) x .500 (12.7)	Vertical	01	Clip/Mtg Hole	57°C @ 2W	7.5°C/W @ 400 LFM
230-75ABE-05	.500 (12.7)	.750 (19.1) x .570 (14.5)	Horizontal	05	Clip/Mtg Hole	57°C @ 2W	7.5°C/W @ 400 LFM
230-75ABE-10	.875 (22.2)	.570 (14.5) x .500 (12.7)	Vertical	10	Clip/Mtg Hole	57°C @ 2W	7.5°C/W @ 400 LFM
234-75AB	.790 (20.0)	.570 (14.5) x .500 (12.7)	Vert./Horiz.	No Tab	Clip/Mtg Hole	57°C @ 2W	7.5°C/W @ 400 LFM
234-75ABE-01	.790 (20.0)	.570 (14.5) x .500 (12.7)	Vertical	01	Clip/Mtg Hole	57°C @ 2W	7.5°C/W @ 400 LFM
234-75ABE-05	.500 (12.7)	.790 (20.0) x .570 (14.5)	Horizontal	05	Clip/Mtg Hole	57°C @ 2W	7.5°C/W @ 400 LFM

Material: Aluminum, Black Anodized

MECHANICAL DIMENSIONS

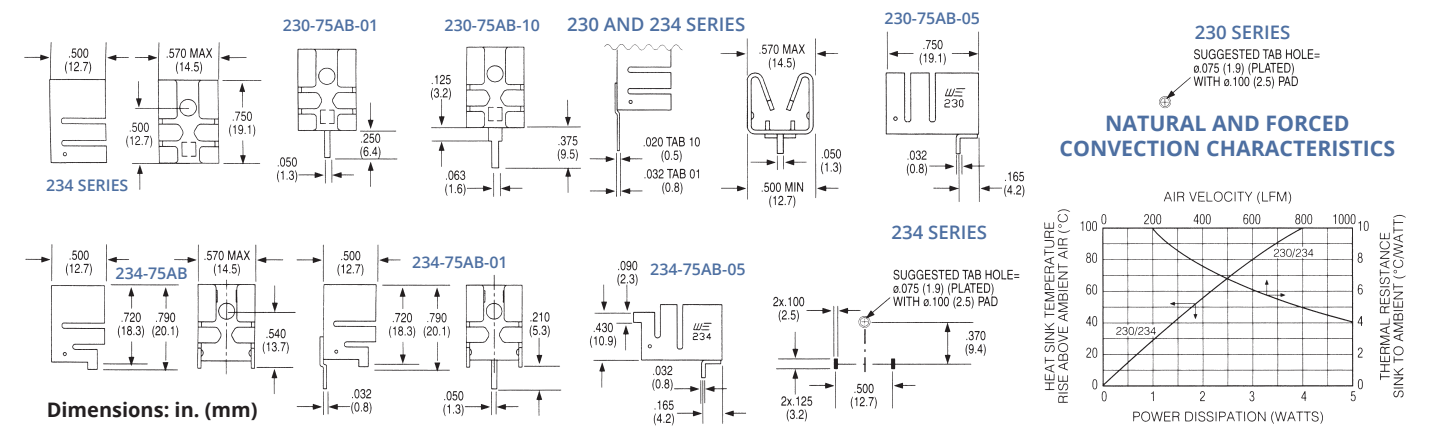

NATURAL AND FORCED CONVECTION CHARACTERISTICS

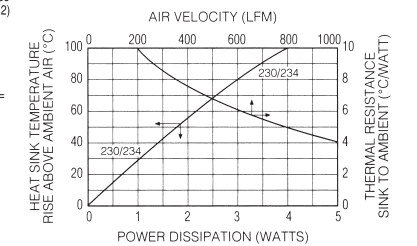

262 SERIES HORIZONTAL AND VERTICAL MOUNT HEAT SINK

TO-220

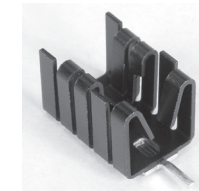

Standard P/N	Height Above PC Board in. (mm)	Maximum Footprint in. (mm)	Thermal Performance at Typical Load	
			Natural Convection	Forced Convection
262-75ABE-05	.53 (13.4)	.75 (19.1) x .50 (12.78)	80°C rise @ 2W	10°C/W @ 200LFM
262-75ABE-01	.75 (19.1)	.53 (13.4) x .50 (12.7)	80°C rise @ 2W	10°C/W @ 200LFM

Material: Aluminum, Black Anodized

MECHANICAL DIMENSIONS

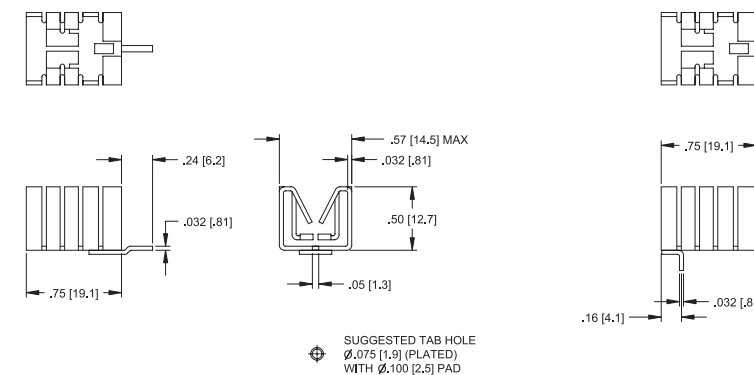

NATURAL AND FORCED CONVECTION CHARACTERISTICS

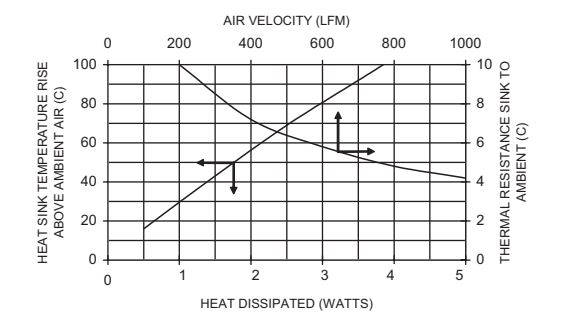

BOARD LEVEL POWER SEMICONDUCTOR HEAT SINKS

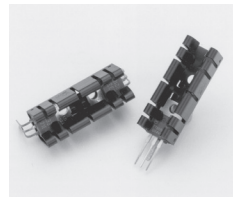

233 & 236 SERIES

SELF-LOCKING WAVE-SOLDERABLE HEAT SINKS

TO-220

PATENT PENDING

Standard P/N	Height Above PC Board in. (mm)	Footprint Dimensions in. (mm)	Mounting Configuration	Solderable Tab Options	Mounting Style	Thermal Performance at Typical Load	
						Natural Convection	Forced Convection
233-60AB	.600(15.2)	.570 (14.5) x .500 (12.7)	Vert./Horiz.	No Tab	Clip/Mtg Hole	58°C @ 2W	11.0°C/W @ 400 LFM
233-60ABE-01	.600(15.2)	.570 (14.5) x .500 (12.7)	Vertical	01	Clip/Mtg Hole	58°C @ 2W	11.0°C/W @ 400 LFM
233-60ABE-05	.500(12.7)	.600 (15.2) x .570 (14.5)	Horizontal	05	Clip/Mtg Hole	58°C @ 2W	11.0°C/W @ 400 LFM
233-60ABE-10	.725(18.4)	.570 (14.5) x .500 (12.7)	Vertical	10	Clip/Mtg Hole	58°C @ 2W	11.0°C/W @ 400 LFM
236-150AB	1.500(38.1)	.570 (14.5) x .500 (12.7)	Vert./Horiz.	No Tab	Clip/Mtg Hole	40°C @ 2W	4.80°C/W @ 400 LFM
236-150ABE-01	1.500(38.1)	.570 (14.5) x .500 (12.7)	Vertical	01	Clip/Mtg Hole	40°C @ 2W	4.80°C/W @ 400 LFM
236-150ABE-05	.500(12.7)	1.500 (38.1) x .570 (14.5)	Horizontal	05	Clip/Mtg Hole	40°C @ 2W	4.80°C/W @ 400 LFM
236-150ABE-10	1.625(41.3)	.570 (14.5) x .570 (12.7)	Vertical	10	Clip/Mtg Hole	40°C @ 2W	4.80°C/W @ 400 LFM

Material: Aluminum, Black Anodized

MECHANICAL DIMENSIONS

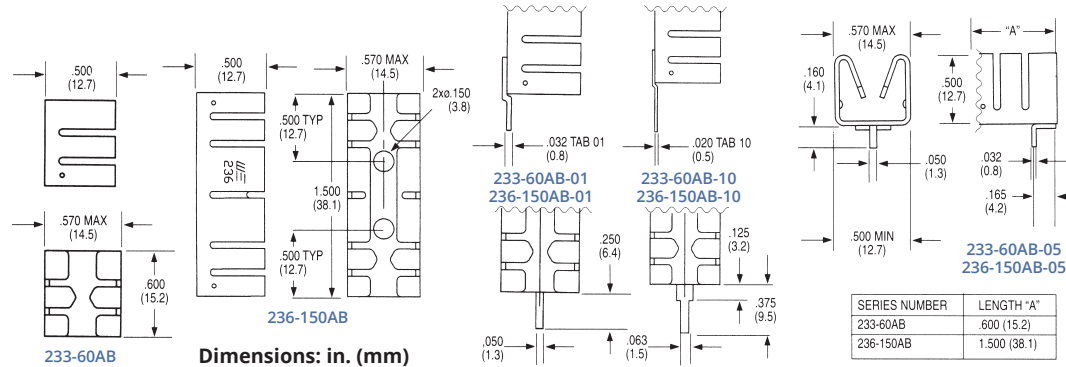

NATURAL AND FORCED CONVECTION CHARACTERISTICS

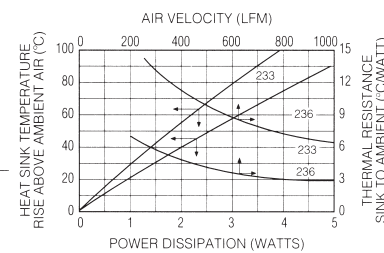

COMPACT, STRESS-FREE LABOR-SAVING LOCKING-TAB HEAT SINKS

275 & 231 SERIES

TO-220

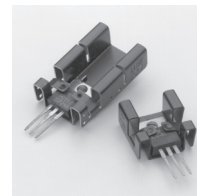

Standard P/N	Height Above PC Board in. (mm)	Footprint Dimensions in. (mm)	Mounting Configuration	Solderable Tab Options	Mounting Style	Thermal Performance at Typical Load	
						Natural Convection	Forced Convection
275-75AB	.750 (19.1)	.835 (21.2) x .400 (12.7)	Vert./Horiz.	No Tab	Clip/Mtg Hole	44°C @ 2W	7.9°C/W @ 400 LFM
275-75ABE-01	.750 (19.1)	.835 (21.2) x .400 (12.7)	Vertical	01	Clip/Mtg Hole	44°C @ 2W	7.9°C/W @ 400 LFM
275-75ABE-10	.875 (12.7)	.835 (21.2) x .400 (14.5)	Vertical	10	Clip/Mtg Hole	44°C @ 2W	7.9°C/W @ 400 LFM
231-69PAB	.690 (18.4)	.835 (21.2) x .400 (12.7)	Vert./Horiz.	No Tab	Clip/Mtg Hole	45°C @ 2W	8°C/W @ 400 LFM
231-69PABE	.400 (10.1)	.690 (17.5) x .835 (12.7)	Horizontal	13H	Clip/Mtg Hole	45°C @ 2W	8°C/W @ 400 LFM
231-69PABE-XXX	.690 (17.5)	.835 (21.2) x .400 (12.7)	Vertical	13V, 14V, 15V	Clip/Mtg Hole	45°C @ 2W	8°C/W @ 400 LFM
231-75PAB	.750 (19.1)	.835 (21.2) x .400 (14.5)	Vert./Horiz.	No Tab	Clip/Mtg Hole	43°C @ 2W	7.9°C/W @ 400 LFM
231-75PABE	.400 (10.1)	.750 (19.1) x .835 (12.7)	Horizontal	13H	Clip/Mtg Hole	43°C @ 2W	7.9°C/W @ 400 LFM
231-75PABE-XXX	.750 (19.1)	.835 (21.2) x .400 (12.7)	Vertical	13V, 14V, 15V	Clip/Mtg Hole	43°C @ 2W	7.9°C/W @ 400 LFM
231-137PAB	1.375 (35)	.835 (21.2) x .400 (12.7)	Vert./Horiz.	No Tab	Clip/Mtg Hole	32°C @ 2W	5.9°C/W @ 400 LFM
231-137PABE	400 (10.2)	1.375 (34.9) x .835 (12.7)	Horizontal	13H	Clip/Mtg Hole	32°C @ 2W	5.9°C/W @ 400 LFM
231-137PABE-XXX	1.375 (35)	.835 (21.2) x .400 (12.7)	Vertical	13V, 14V, 15V	Clip/Mtg Hole	32°C @ 2W	5.9°C/W @ 400 LFM

Material: Aluminum, Pre-anodized Black (PAB), Anodized Black (AB)

PATENT 5381041

TO-220

COMPACT, STRESS-FREE LABOR-SAVING LOCKING-TAB HEAT SINKS

275 & 231 SERIES

MECHANICAL DIMENSIONS

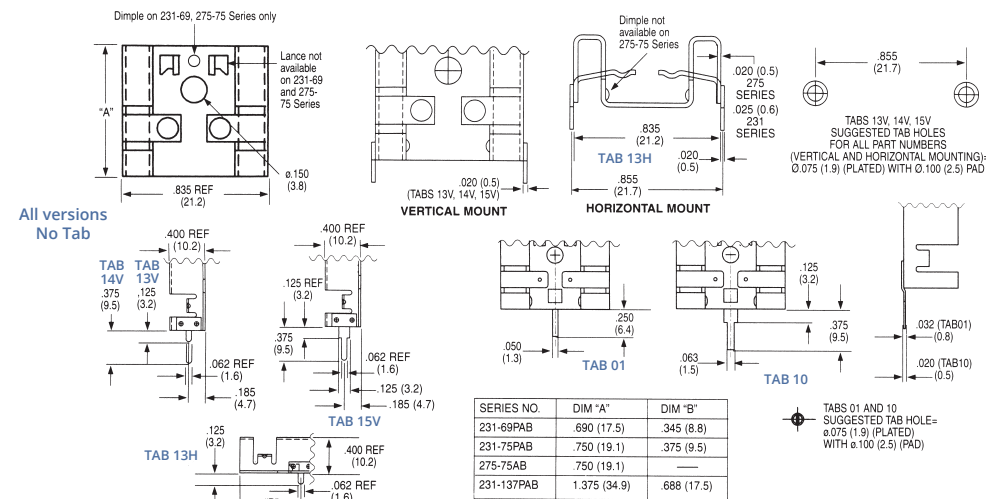

SERIES NO.	DIM "A"	DIM "B"
231-69PAB	.690 (17.5)	.345 (8.8)
231-75PAB	.750 (19.1)	.375 (9.5)
275-75AB	.750 (19.1)	---
231-137PAB	1.375 (34.9)	.688 (17.5)

Dimensions: in. (mm)

NATURAL AND FORCED CONVECTION CHARACTERISTICS

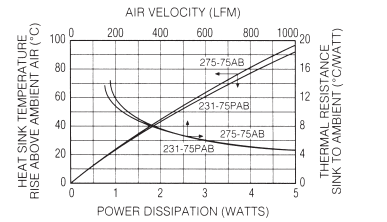

NATURAL AND FORCED CONVECTION CHARACTERISTICS

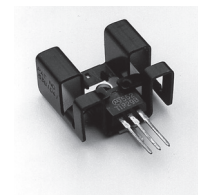
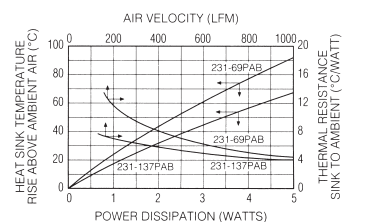

235 SERIES

COMPACT, STRESS-FREE LABOR-SAVING LOCKING-TAB HEAT SINKS

TO-220

PATENT 5381041

Standard P/N	Height Above PC Board in. (mm)	Footprint Dimensions in. (mm)	Mounting Configuration	Solderable Tab Options	Mounting Style	Thermal Performance at Typical Load	
						Natural Convection	Forced Convection
235-85AB	.850 (21.6)	1.000 (25.4) x .500 (12.7)	Vert./Horiz.	No Tab	Clip/Mtg Hole	40°C @ 2W	6.8°C/W @ 400 LFM
235-85ABE-01	.850 (21.6)	1.000 (25.4) x .500 (12.7)	Vertical	01	Clip/Mtg Hole	40°C @ 2W	6.8°C/W @ 400 LFM
235-85ABE-05	.500 (12.7)	.850 (21.6) x 1.000 (25.4)	Horizontal	05	Clip/Mtg Hole	40°C @ 2W	6.8°C/W @ 400 LFM
235-85ABE-10	.975 (24.8)	1.000 (25.4) x .500 (12.7)	Vertical	10	Clip/Mtg Hole	40°C @ 2W	6.8°C/W @ 400 LFM

Material: Aluminum, Black Anodized

MECHANICAL DIMENSIONS

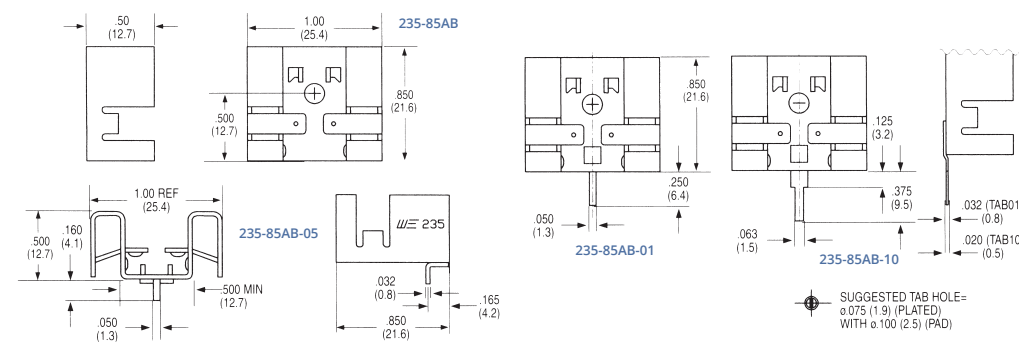

Dimensions: in. (mm)

NATURAL AND FORCED CONVECTION CHARACTERISTICS

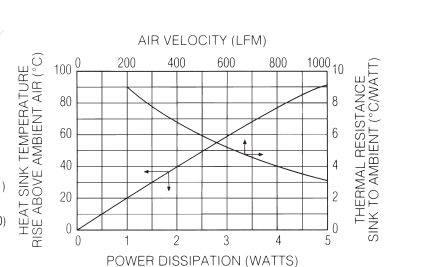

BOARD LEVEL POWER SEMICONDUCTOR HEAT SINKS

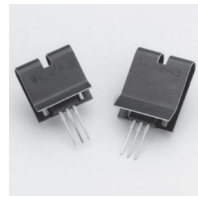

243 SERIES

LABOR-SAVING CLIP-ON HEAT SINKS

TO-220

Standard P/N	Height Above PC Board in. (mm)	Footprint Dimensions in. (mm)	Mounting Configuration	Solderable Tab Options	Mounting Style	Thermal Performance at Typical Load	
						Natural Convection	Forced Convection
243-1PAB	1.000 (25.4)	.800 (20.3) x .270 (6.9)	Vert./Horiz.	No Tab	Clip	50°C@ 2W	4.5°C/W @ 400 LFM
243-3PAB	.800 (20.3)	.800 (20.3) x .270 (6.9)	Verl./Horiz.	No Tab	Clip	78°C@ 2W	8.2°C/W @ 400 LFM

Material: Aluminum, Pre-anodized Black

MECHANICAL DIMENSIONS

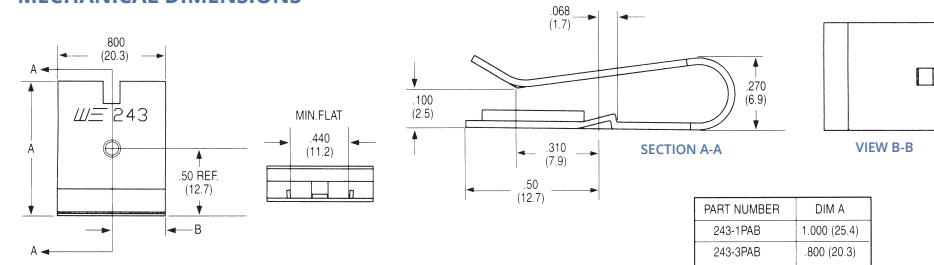

Dimensions: in. (mm)

NATURAL AND FORCED CONVECTION CHARACTERISTICS

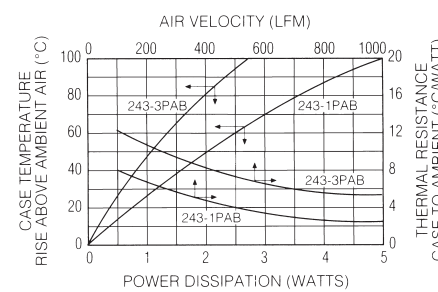

MECHANICAL DIMENSIONS

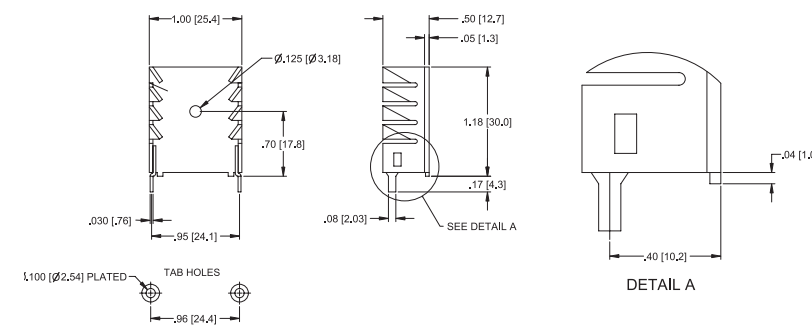

NATURAL AND FORCED CONVECTION CHARACTERISTICS

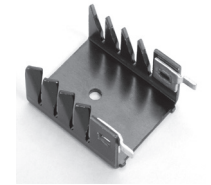
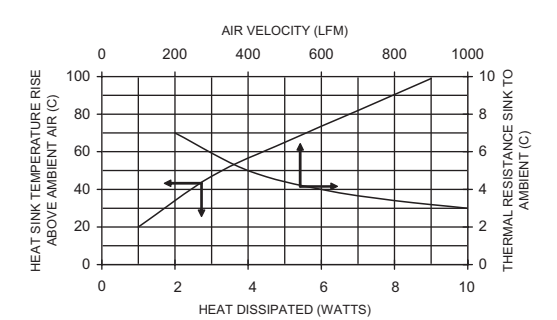

VERTICAL MOUNT HEAT SINK

265 SERIES

TO-220

Standard P/N	Height Above PC Board in. (mm)	Maximum Footprint in. (mm)	Thermal Performance at Typical Load	
			Natural Convection	Forced Convection
265-118ABHE-22	1.18 (30.0)	1.00 (25.4) x .50 (12.7)	56°C rise @ 4W	7.0°C/W @ 200LFM

Material: Aluminum, Black Anodized

TO-220

SNAP-DOWN SELF-LOCKING HEAT SINKS

239 SERIES



PATENT PENDING

Standard P/N	Height Above PC Board in. (mm)	Footprint Dimensions in. (mm)	Mounting Configuration	Solderable Tab Options	Mounting Style	Thermal Performance at Typical Load	
						Natural Convection	Forced Convection
239-75AB	.750 (19.1)	1.120 (28.4) x .435 (11.0)	Vert./Horiz	No Tab	Clip/Mtg Hole	38°C @ 2W	6°C/W @ 400 LFM
239-75ABE-03	.750 (19.1)	1.120 (28.4) x .435 (11.0)	Vertical	03	Clip/Mtg Hole	38°C @ 2W	6°C/W @ 400 LFM
239-75ABE-04	.750 (19.1)	1.120 (28.4) x .435 (11.0)	Vertical	04	Clip/Mtg Hole	38°C @ 2W	6°C/W @ 400 LFM

Material: Aluminum, Black Anodized

MECHANICAL DIMENSIONS

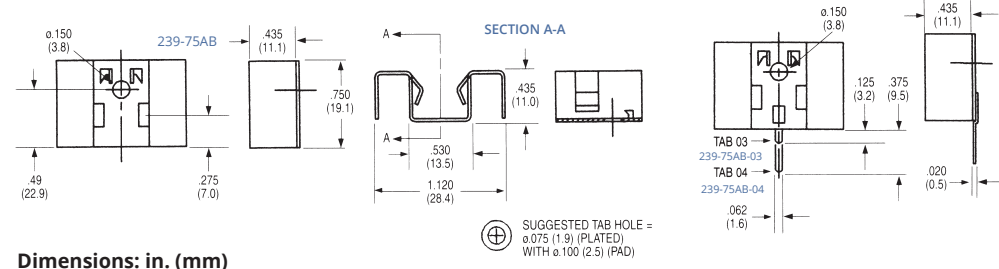

Dimensions: in. (mm)

NATURAL AND FORCED CONVECTION CHARACTERISTICS

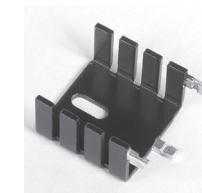
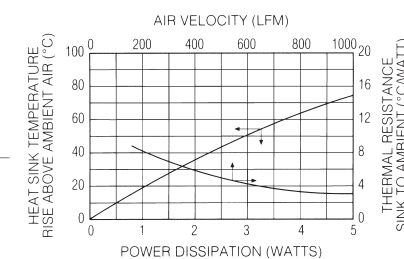

286DB SERIES

VERTICAL MOUNT HEAT SINK

TO-220

Standard P/N	Height Above PC Board in. (mm)	Maximum Footprint in. (mm)	Thermal Performance at Typical Load	
			Natural Convection	Forced Convection
286DBE	.95 (24.1)	1.00 (25.4) x .50 (12.7)	65°C rise @ 4W	9.0°C/W @ 200LFM

Material: Aluminum, Black Anodized

MECHANICAL DIMENSIONS

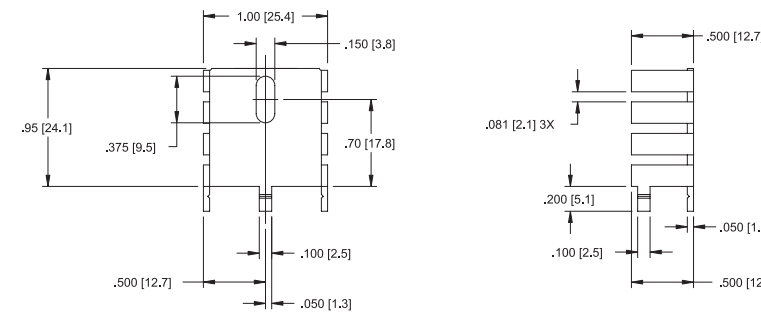

NATURAL AND FORCED CONVECTION CHARACTERISTICS

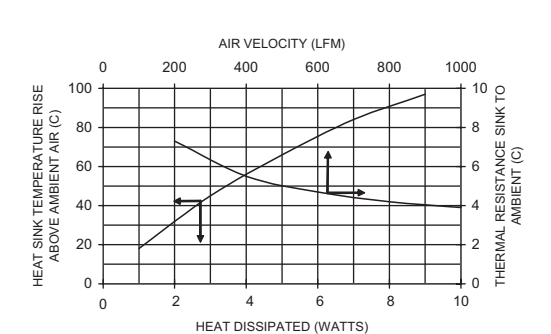

Contact us: (603) 635-2800

BOARD LEVEL POWER SEMICONDUCTOR HEAT SINKS

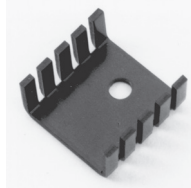

273 SERIES

LOW-COST, LOW-HEIGHT WAVE-SOLDERABLE HEAT SINKS

TO-220 and TO-218

Standard P/N	Height Above PC Board in. (mm)	Footprint Dimensions in. (mm)	Mounting Configuration	Solderable Tab Options	Mounting Style	Thermal Performance at Typical Load	
						Natural Convection	Forced Convection
273-AB	.375 (9.5)	.750 (19.1) x .750 (19.1)	Vert./Horiz.	No Tab	Mtg Hole	49°C @ 2W	7.2°C/W @ 400 LFM
273-ABE-01	.375 (9.5)	.750 (19.1) x .750 (19.1)	Vertical	01	Mtg Hole	49°C @ 2W	7.2°C/W @ 400 LFM
273-ABE-02	.375 (9.5)	.750 (19.1) x .750 (19.1)	Vertical	02	Mtg Hole	49°C @ 2W	7.2°C/W @ 400 LFM

Material: Aluminum, Black Anodized

MECHANICAL DIMENSIONS

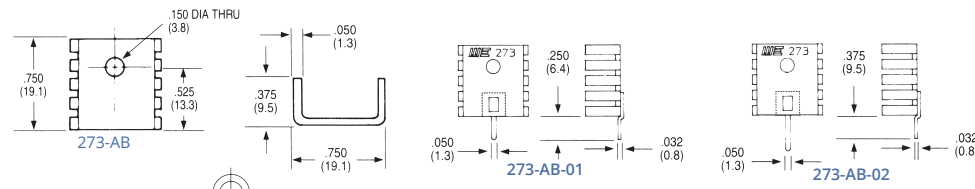

Note:
1. Suggested Tab Hole = ϕ .075 (1.9) (Plated) with ϕ .100 (2.5) pad

Dimensions: in. (mm)

NATURAL AND FORCED CONVECTION CHARACTERISTICS

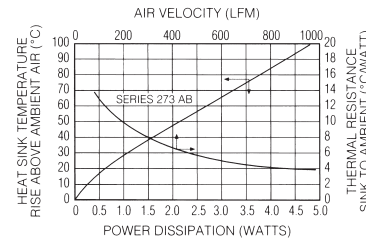

LOW-COST, LOW-HEIGHT WAVE-SOLDERABLE HEAT SINKS

274 & 281 SERIES

TO-220

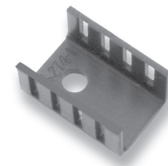

Standard P/N	Height Above PC Board in. (mm)	Footprint Dimensions in. (mm)	Mounting Configuration	Solderable Tab Options	Mounting Style	Thermal Performance at Typical Load	
						Natural Convection	Forced Convection
274-1AB	.375 (9.5)	.520 (13.2) x .750 (19.1)	Vert./Horiz.	No Tab	Mtg Hole	56°C @ 2W	8.0°C/W @ 400 LFM
274-1ABE-01	.375 (9.5)	.520 (13.2) x .750 (19.1)	Vertical	01	Mtg Hole	56°C @ 2W	8.0°C/W @ 400 LFM
274-1ABE-02	.375 (9.5)	.520 (13.2) x .750 (19.1)	Vertical	02	Mtg Hole	56°C @ 2W	8.0°C/W @ 400 LFM
274-2AB	.500 (12.7)	.520 (13.2) x .750 (19.1)	Vert./Horiz.	No Tab	Mtg Hole	50°C @ 2W	7.0°C/W @ 400 LFM
274-2ABE-01	.500 (12.7)	.520 (13.2) x .750 (19.1)	Vertical	01	Mtg Hole	50°C @ 2W	7.0°C/W @ 400 LFM
274-2ABE-02	.500 (12.7)	.520 (13.2) x .750 (19.1)	Vertical	02	Mtg Hole	50°C @ 2W	7.0°C/W @ 400 LFM
274-3AB	.250 (6.4)	.520 (13.2) x .750 (19.1)	Vert./Horiz.	No Tab	Mtg Hole	62°C @ 2W	9.0°C/W @ 400 LFM
274-3ABE-01	.250 (6.4)	.520 (13.2) x .750 (19.1)	Vertical	01	Mtg Hole	62°C @ 2W	9.0°C/W @ 400 LFM
274-3ABE-02	.250 (6.4)	.520 (13.2) x .750 (19.1)	Vertical	02	Mtg Hole	62°C @ 2W	9.0°C/W @ 400 LFM
281-1AB	.375 (9.5)	.520 (13.2) x .750 (19.1)	Vertical	No Tab	Mtg Hole	56°C @ 2W	8.0°C/W @ 400 LFM
281-2AB	.500 (12.7)	.520 (13.2) x .750 (19.1)	Vertical	No Tab	Mtg Hole	50°C @ 2W	7.0°C/W @ 400 LFM

Material: Aluminum, Black Anodized

MECHANICAL DIMENSIONS

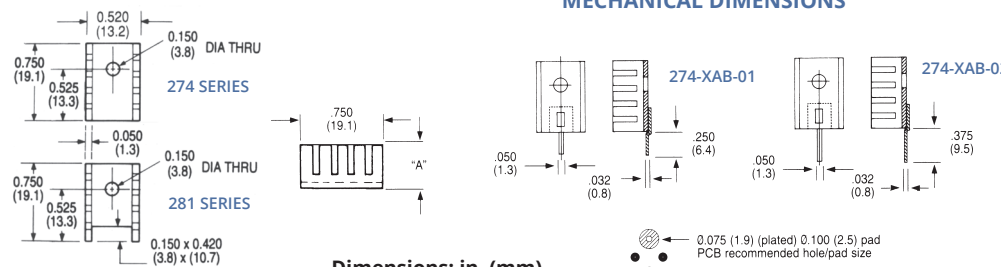

Dimensions: in. (mm)

NATURAL AND FORCED CONVECTION CHARACTERISTICS

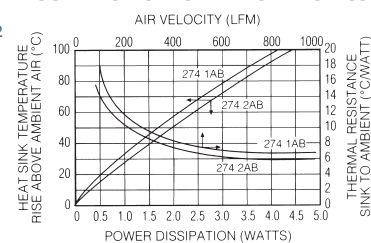

TO-220

LABOR-SAVING TWISTED FIN HEAT SINKS

240 SERIES

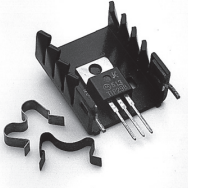

Standard P/N	Height Above PC Board in. (mm)	Footprint Dimensions in. (mm)	Mounting Configuration	Solderable Tab Options	Mounting Style	Thermal Performance at Typical Load	
						Natural Convection	Forced Convection
240-118ABEH-22	1.180 (30.0)	1.000 (25.4) x .500 (12.7)	Vertical	22	Clip/Mtg Hole	55°C @ 4W	5.3°C/W @ 400 LFM
240-118ABES-22	1.180 (30.0)	1.000 (25.4) x .500 (12.7)	Vertical	22	Clip/Mtg Slot	55°C @ 4W	5.3°C/W @ 400 LFM

Material: Aluminum, Black Anodized

MECHANICAL DIMENSIONS

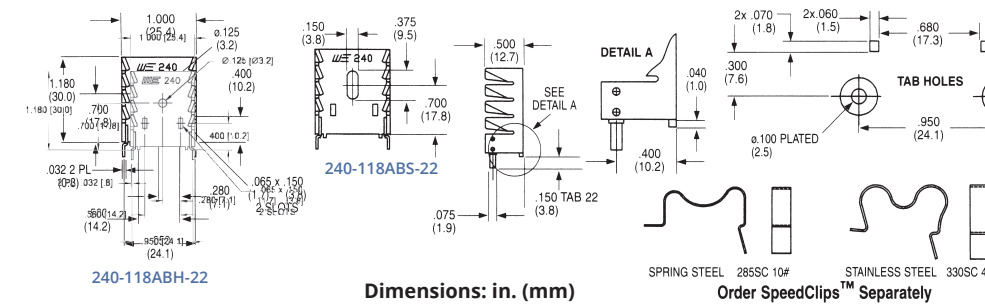

Dimensions: in. (mm)

NATURAL AND FORCED CONVECTION CHARACTERISTICS

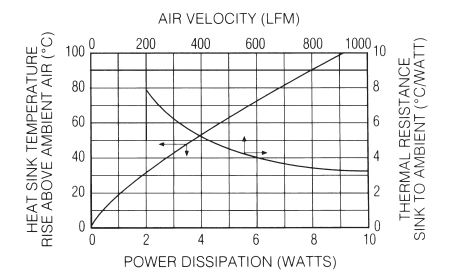

242 SERIES

LOW-COST, LOW-HEIGHT WAVE-SOLDERABLE HEAT SINKS

TO-220

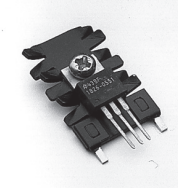

Standard P/N	Height Above PC Board in. (mm)	Footprint Dimensions in. (mm)	Mounting Configuration	Solderable Tab Options	Mounting Style	Thermal Performance at Typical Load	
						Natural Convection	Forced Convection
242-125ABE-22	1.285 (32.6)	.875 (22.2) x .250 (6.4)	Vertical	22	Mtg Hole	48°C @ 2W	6.2°C/W @ 400 LFM

Material: Aluminum, Black Anodized

MECHANICAL DIMENSIONS

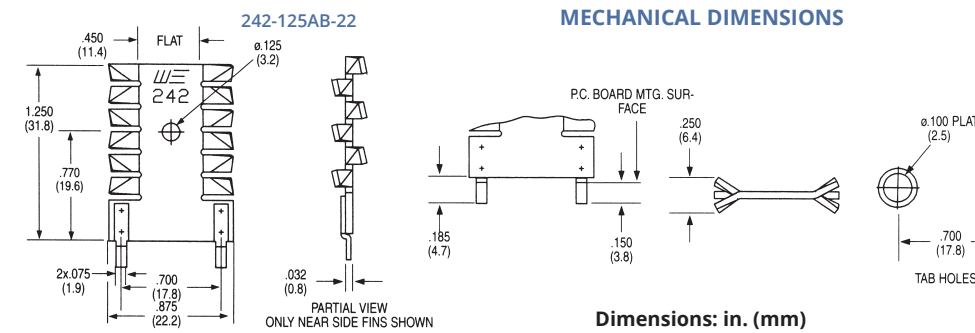

Dimensions: in. (mm)

NATURAL AND FORCED CONVECTION CHARACTERISTICS

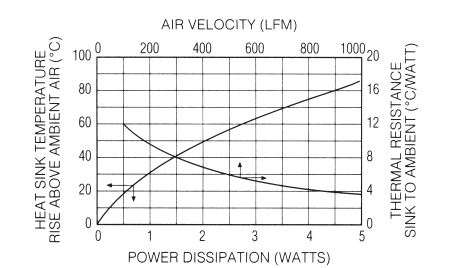

BOARD LEVEL POWER SEMICONDUCTOR HEAT SINKS

BOARD LEVEL HEAT SINKS FOR TO-220, TO-218 & MULTIWATT™ COMPONENTS



232 & 238 SERIES

STAGGERED FIN HEAT SINKS FOR VERTICAL MOUNTING

TO-220 and TO-202

Standard P/N	Height Above PC Board in. (mm)	Footprint Dimensions in. (mm)	Mounting Configuration	Solderable Tab Options	Mounting Style	Thermal Performance at Typical Load	
						Natural Convection	Forced Convection
232-200AB	2.000 (50.8)	1.380 (35.1) x .500 (12.7)	Vertical	2, Twisted	Clip/Mtg Hole	48°C @ 4W	3.3°C/W @ 400 LFM
232-200ABE-23	2.000 (50.8)	1.380 (35.1) x .500 (12.7)	Vertical	2, Solderable	Clip/Mtg Hole	48°C @ 4W	3.3°C/W @ 400 LFM
238-200AB	2.000 (50.8)	1.380 (35.1) x .500 (12.7)	Vertical	2, Twisted	Mtg Slot	48°C @ 4W	3.3°C/W @ 400 LFM
238-200ABE-23	2.000 (50.8)	1.380 (35.1) x .500 (12.7)	Vertical	2, Solderable	Mtg Slot	48°C @ 4W	3.3°C/W @ 400 LFM

Material: Aluminum, Black Anodized

MECHANICAL DIMENSIONS

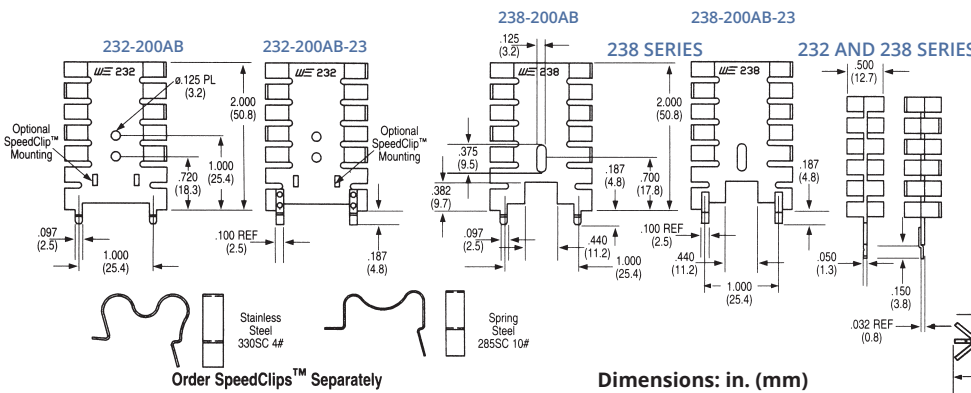

NATURAL AND FORCED CONVECTION CHARACTERISTICS

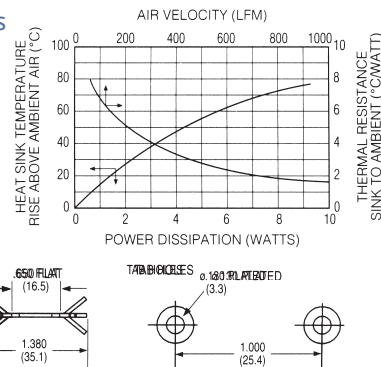

15 Lead Multiwatt

SLIM-PROFILE HEAT SINKS WITH INTEGRAL CLIPS

251 SERIES

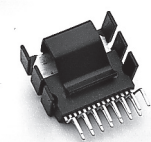

Standard P/N	Height Above PC Board in. (mm)	Footprint Dimensions in. (mm)	Mounting Configuration	Solderable Tab Options	Mounting Style	Thermal Performance at Typical Load	
						Natural Convection	Forced Convection
251-62AB	.620 (15.7)	.910 (23.1) x .380 (9.7)	Vert./Horiz.	No Tab	Clip	66°C @ 3W	66°C/W @ 400 LFM
251-80AB	.845 (21.5)	.910 (23.1) x .380 (9.7)	Vert./Horiz.	No Tab	Clip	64°C @ 3W	66°C/W @ 400 LFM
251-80ABE-19	.875 (22.2)	.910 (23.1) x .380 (9.7)	Vertical	19	Clip	64°C @ 3W	66°C/W @ 400 LFM

Material: Aluminum, Black Anodized

MECHANICAL DIMENSIONS

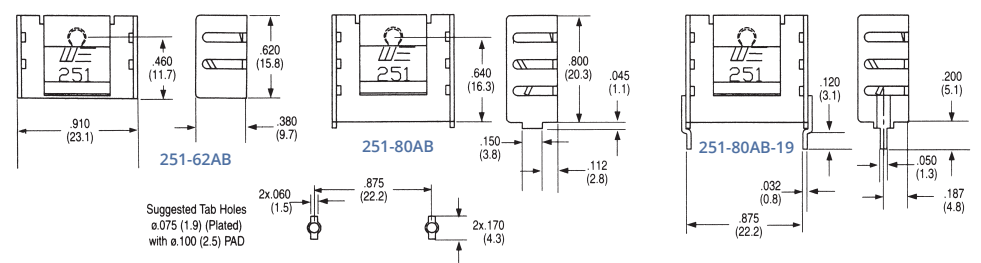

Dimensions: in. (mm)

NATURAL AND FORCED CONVECTION CHARACTERISTICS

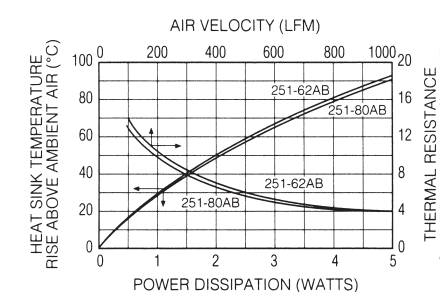

Multiwatt

LOW HEIGHT, SLIM PROFILE WAVE-SOLDERABLE FOLDED FIN HEAT SINKS

244 SERIES



Standard P/N	Height Above PC Board in. (mm)	Footprint Dimensions in. (mm)	Mounting Configuration	Solderable Tab Options	Thermal Performance at Typical Load		Weight lbs. (grams)
					Natural Convection	Force Convection	
244-145AB	1.450 (36.8)	1.300 (33.0) x 480 (12.1)	Vert/Horiz.	No Tab	44°C @ 4W	4.4°C/W @ 400 LFM	.0160 (7.25)
244-145ABE-50	1.650 (41.9)	1.300 (33.0) x 480 (12.1)	Vertical	50	44°C @ 4W	4.4°C/W @ 400 LFM	.0170 (7.20)

Material: Aluminum, Black Anodized

MECHANICAL DIMENSIONS

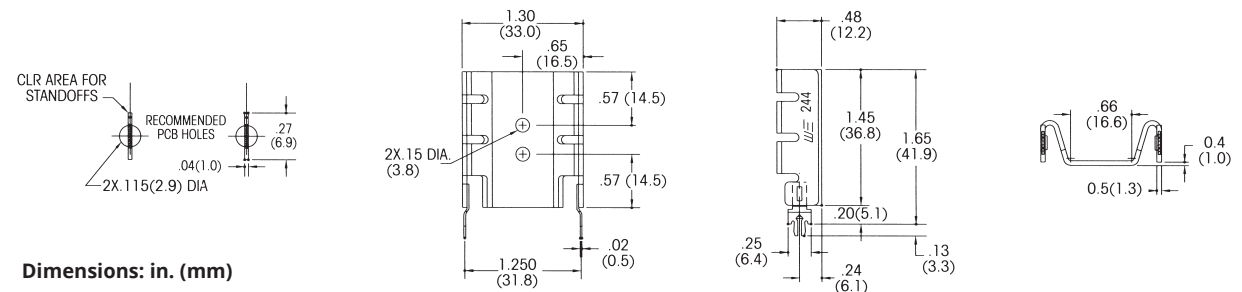

Dimensions: in. (mm)



245 SERIES

LOW HEIGHT, SLIM PROFILE WAVE-SOLDERABLE FOLDED FIN HEAT SINKS

Multiwatt

Standard P/N	Height Above PC Board in. (mm)	Footprint Dimensions in. (mm)	Mounting Configuration	Solderable Tab Options	Thermal Performance at Typical Load		Weight lbs. (grams)
					Natural Convection	Forced Convection	
245-145AB	1.450 (36.8)	1.750 (44.5) x .380 (9.7)	Ver.t/Horiz.	No Tab	38°C @ 4W	3.2°C/W @ 400 LFM	.0160 (7.25)
245-145ABE-50	1.650 (41.9)	1.750 (44.5) x .380 (9.7)	Vertical	50	38°C @ 4W	3.2°C/W @ 400 LFM	.0170 (7.20)

Material: Aluminum, Black Anodized

MECHANICAL DIMENSIONS

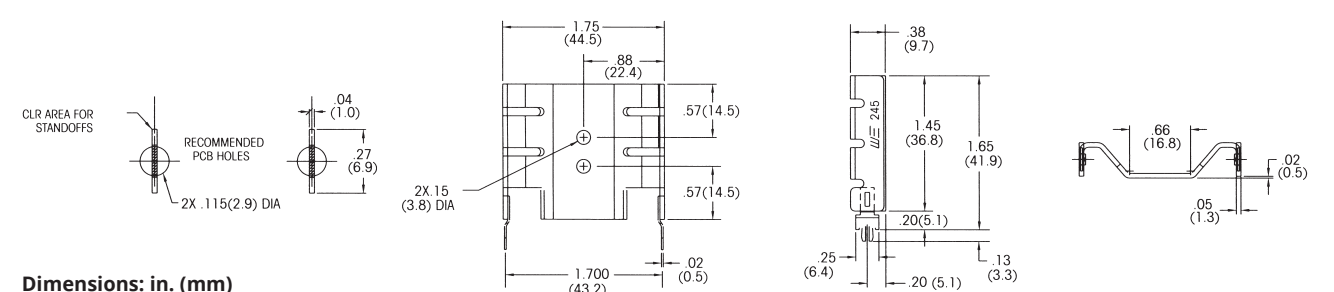

Dimensions: in. (mm)

Contact us: (603) 635-2800

BOARD LEVEL HEAT SINKS FOR TO-220, TO-218 & MULTIWATT™ COMPONENTS

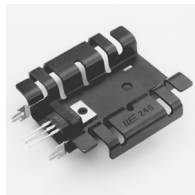

246 SERIES

MEDIUM HEIGHT, SLIM PROFILE WAVE-SOLDERABLE FOLDED FIN HEAT SINKS

Multiwatt

Standard P/N	Height Above PC Board in. (mm)	Footprint Dimensions in. (mm)	Mounting Configuration	Solderable Tab Options	Thermal Performance at Typical Load		Weight lbs. (grams)
					Natural Convection	Forced Convection	
246-197AB	1.968 (50.0)	1.986 (50.4) x 3.75 (9.5)	Vert./Horiz.	No Tab	35°C @ 4W	2.8°C/W @ 400 LFM	.0240 (10.90)
246-197ABE-50	2.168 (55.1)	1.986 (50.4) x 3.75 (9.5)	Vertical	50	35°C @ 4W	2.8°C/W @ 400 LFM	.0250 (11.40)

Order SpeedClip™ 2855C or 3305C separately. (See 248 Series section).
Material: Aluminum, Black Anodized

MECHANICAL DIMENSIONS

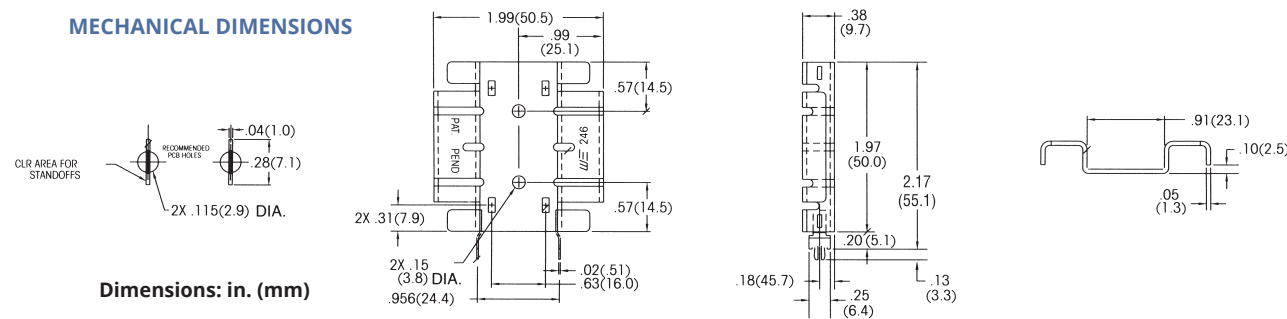

LOW HEIGHT, MEDIUM PROFILE WAVE-SOLDERABLE FOLDED FIN HEAT SINKS

Multiwatt

248 SERIES

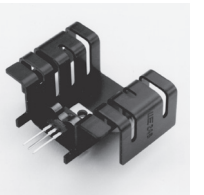

Standard P/N	Height Above PC Board in. (mm)	Footprint Dimensions in. (mm)	Mounting Configuration	Solderable Tab Options	Thermal Performance at Typical Load		Weight lbs. (grams)
					Natural Convection	Forced Convection	
248-162AB	1.620 (41.1)	2.000 (50.8) x .750 (19.1)	Vert./Horiz.	No Tab	35°C @ 4W	2.5°C/W @ 400 LFM	.026 (11.60)
248-162ABE-50	1.620 (41.1)	2.000 (50.8) x .750 (19.1)	Vertical	50	35°C @ 4W	2.5°C/W @ 400 LFM	.027 (12.20)

Order SpeedClip™ 2855C or 3305C separately.
Material: Aluminum, Black Anodized

MECHANICAL DIMENSIONS

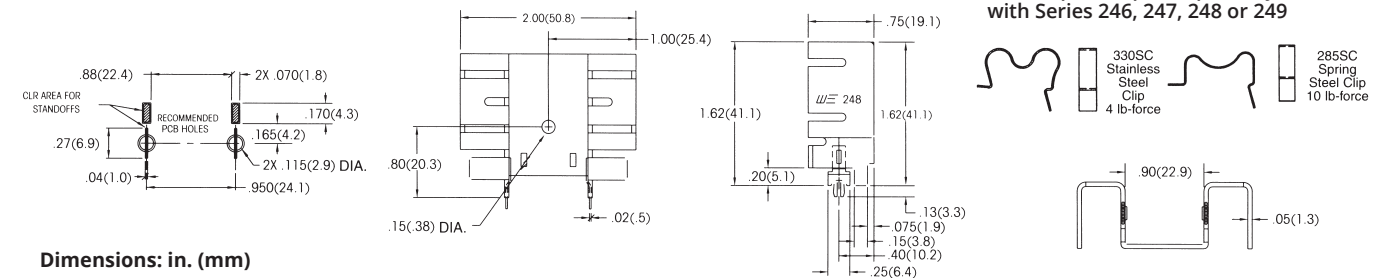

MEDIUM HEIGHT, DEEP PROFILE WAVE-SOLDERABLE FOLDED FIN HEAT SINKS

Multiwatt

247 SERIES

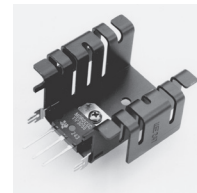

Standard P/N	Height Above PC Board in. (mm)	Footprint Dimensions in. (mm)	Mounting Configuration	Solderable Tab Options	Thermal Performance at Typical Load		Weight lbs. (grams)
					Natural Convection	Forced Convection	
247-195AB	1.950 (49.5)	1.900 (48.3) x .950 (24.1)	Vert./Horiz.	No Tab	25°C @ 4W	2.4°C/W @ 400 LFM	.0330 (15.10)
247-195ABE-50	1.950 (49.5)	1.900 (48.3) x .950 (24.1)	Vertical	50	25°C @ 4W	2.4°C/W @ 400 LFM	.0340 (15.60)

Order SpeedClip™ 2855C or 3305C separately. (See 248 Series section).
Material: Aluminum, Black Anodized

MECHANICAL DIMENSIONS

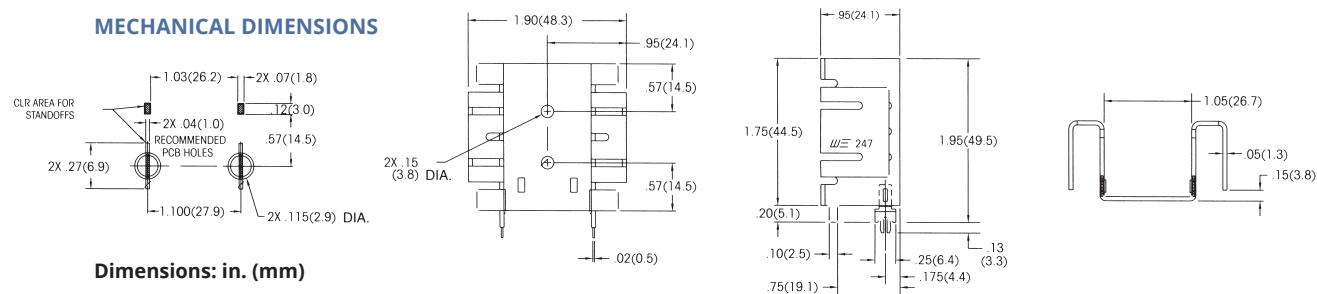

MEDIUM HEIGHT, DEEP PROFILE WAVE-SOLDERABLE FOLDED FIN HEAT SINKS

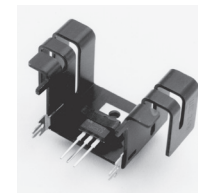

249 SERIES

Multiwatt

Standard P/N	Height Above PC Board in. (mm)	Footprint Dimensions in. (mm)	Mounting Configuration	Solderable Tab Options	Thermal Performance at Typical Load		Weight lbs. (grams)
					Natural Convection	Forced Convection	
249-113AB	1.130 (28.7)	1.900 (48.3) x .950 (24.1)	Vert./Horiz.	No Tab	35°C @ 4W	3.29°C/W @ 400 LFM	.020 (8.90)
249-113ABE-50	1.130 (28.7)	1.900 (48.3) x .950 (24.1)	Vertical	50	35°C @ 4W	3.29°C/W @ 400 LFM	.021 (9.40)

Order SpeedClip™ 2855C or 3305C separately. (See 248 Series section).
Material: Aluminum, Black Anodized

MECHANICAL DIMENSIONS

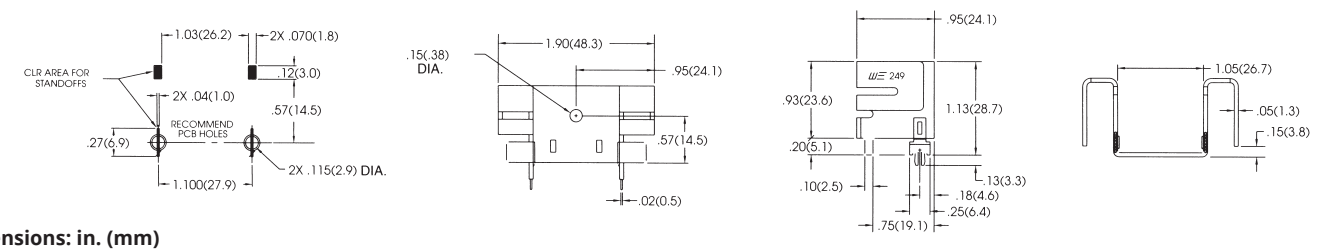

BOARD LEVEL POWER SEMICONDUCTOR HEAT SINKS

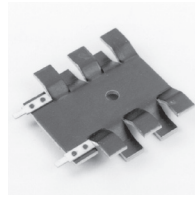

288 SERIES

COMPACT WAVE-SOLDERABLE LOW-COST HEAT SINKS

TO-220 and TO-202

Mounting tabs are pre-tinned to ensure excellent wave-solder bond and good electrical connections for vertical mounting of TO-220 and TO-202 semiconductor packages. These heat sinks are designed for use where minimum PC board space is available. The 288-1AB is a stamped aluminum heat sink, black anodized, designed for applications requiring good heat dissipation from a heat sink occupying minimum space, available at minimum cost.

Standard P/N	Height Above PC Board in. (mm)	Maximum Footprint in. (mm)	Thermal Performance at Typical Load		Weight lbs. (grams)
			Natural Convection	Forced Convection	
288-1ABE	1.250 (31.8)	0.875 (22.2) x 0.215 (5.5)	85°C @ 4W	12°C/W @ 200 LFM	0.0057 (2.59)

MECHANICAL DIMENSIONS

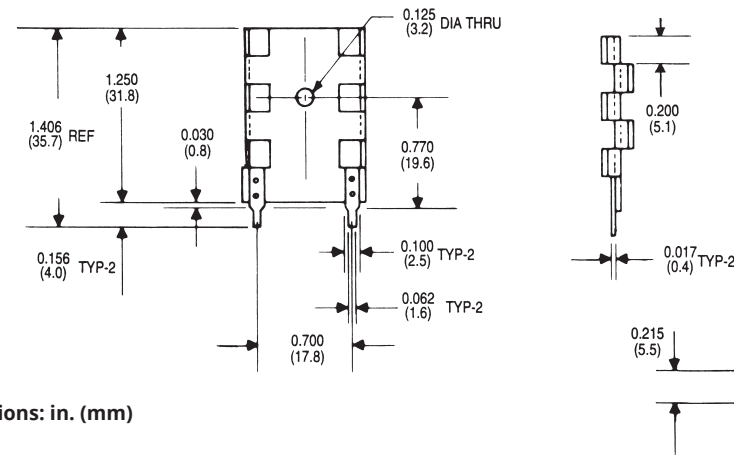

Dimensions: in. (mm)

NATURAL AND FORCED CONVECTION CHARACTERISTICS

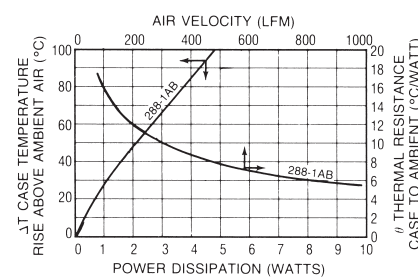

TOP-MOUNT BOOSTER HEAT SINKS FOR USE WITH 270/272/280 SERIES

271 SERIES

TO-220

MECHANICAL DIMENSIONS

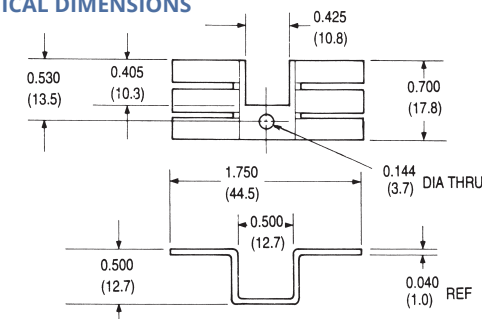

Dimensions: in. (mm)

NATURAL AND FORCED CONVECTION CHARACTERISTICS

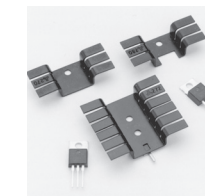
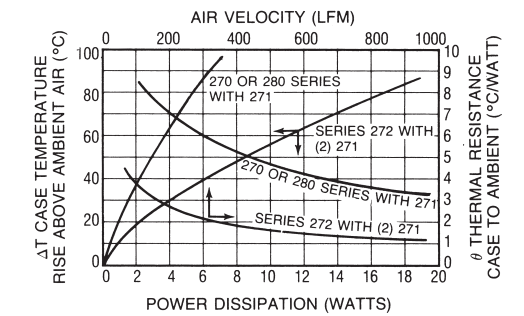

270, 272, & 280 SERIES

SMALL FOOTPRINT LOW-COST HEAT SINKS

TO-220 and TO-202

These exceptionally low-cost heat sinks can be mounted horizontally under a TO-220 or TO-202 case style with a maximum height of only 0.375 in. (9.4). For added performance, a 271 Series heat sink can also be used for double-sided heat dissipation. The 270-AB and 280-AB accept one power semiconductor; the 272-AB is designed for two power semiconductors. Specify solderable tab options for the 272 Series by the addition of suffix "O1" or "O2" to the standard part number (i.e. 272-ABO1 or 272-ABO2).

Standard P/N	Height Above PC Board in. (mm)	Horizontal Mounting Maximum Footing in. (mm)	Solderable Tab Options	Thermal Performance at Typical Load		Weight lbs. (grams)
				Natural Convection	Forced Convection	
270-AB	0.375 (9.4)	1.750 (44.5) x 0.700 (17.8)	—	70°C @ 4W	6.0°C/W @ 400 LFM	0.0052 (2.36)
272-AB	0.375 (9.4)	1.750 (44.5) x 1.450 (36.8)	01,02	42°C @ 4W	3.6°C/W @ 400 LFM	0.0105 (5.72)
280-AB	0.375 (9.4)	1.750 (44.5) x 0.700 (17.8)	—	70°C @ 4W	6.0°C/W @ 400 LFM	0.0048 (2.18)

Material: Aluminum, Black Anodized

TOP-MOUNT BOOSTER HEAT SINKS FOR USE WITH 270/272/280 SERIES

271 SERIES

TO-220

This top-hat style booster heat sink can be added to any of the 270, 272, or 280 Series for improved performance. NOTE A: Thermal resistance with one 271-AB. NOTE B: Thermal resistance (total) as shown with (2) 271-AB types added to (1) 272-AB type.



Standard P/N	Height Above Semiconductor Case in. (mm)	Horizontal Mounting Footprint Dimensions in. (mm)	Thermal Performance at Typical Load		Weight lbs. (grams)
			Natural Convection	Forced Convection	
271-AB	0.500 (12.7)	1.750 (44.5) x 0.700 (17.8)	62°C @ 4W (NOTE A) 31°C @ 4W (NOTE B)	5.1°C/W @ 400 LFM 1.8°C/W 400 LFM (NOTE B)	0.0052 (2.36)

Material: Aluminum, Black Anodized

MECHANICAL DIMENSIONS

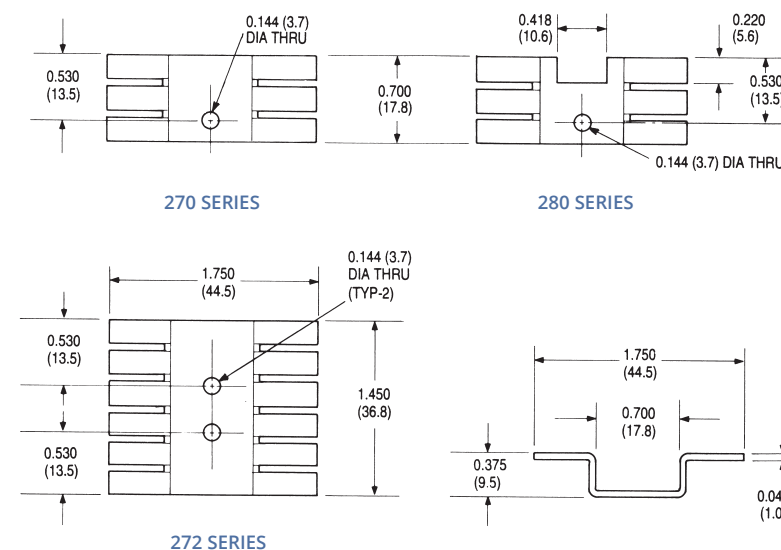

Dimensions: in. (mm)

NATURAL AND FORCED CONVECTION CHARACTERISTICS

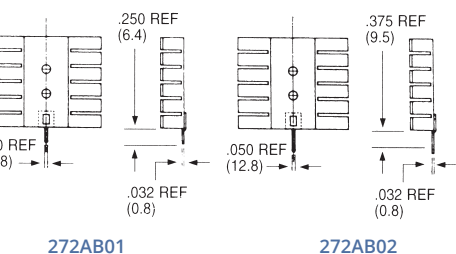
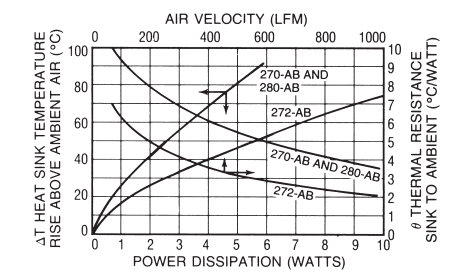

272AB01 272AB02

Note: 1. Suggested Tab Hole = 0.075 ±0.003 plated with 0.100 pad

BOARD LEVEL POWER SEMICONDUCTOR HEAT SINKS

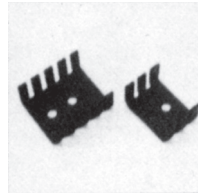

289 & 290 SERIES

LOW-COST SINGLE OR DUAL PACKAGE
HEAT SINKS

TO-218; TO-202; TO-220

Low in cost and compact in overall dimensions, one **289 Series** heat sink can accommodate one semiconductor; the **289 Series** is available with a black anodized finish (289-AB) or with no finish (289-AP). Two semiconductors can be mounted to the 290-2AB style.

Standard P/N	Height Above PC Board in. (mm)	Horizontal Mounting Maximum Footing in. (mm)	Thermal Performance at Typical Load		Weight lbs. (grams)
			Natural Convection	Forced Convection	
289-AB	0.500 (12.7)	1.000 (25.4) x 0.710 (18.1)	50°C @ 2W	9.0 C/W @ 400 LFM	0.0055 (2.49)
289-AP	0.500 (12.7)	1.000 (25.4) x 0.710 (18.1)	50°C @ 2W	9.0 C/W @ 400 LFM	0.0055 (2.49)
290-1AB	0.500 (12.7)	1.000 (25.4) x 1.180 (30.0)	44°C @ 2W	7.0 C/W @ 400 LFM	0.0082 (3.72)
290-2AB	0.500 (12.7)	1.000 (25.4) x 1.180 (30.0)	44°C @ 2W	7.0 C/W @ 400 LFM	0.0081 (3.67)

Material: Aluminum, Black Anodized

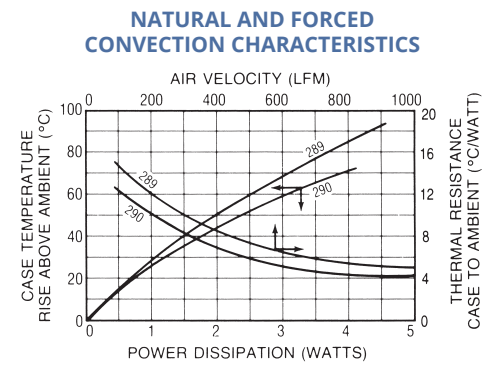
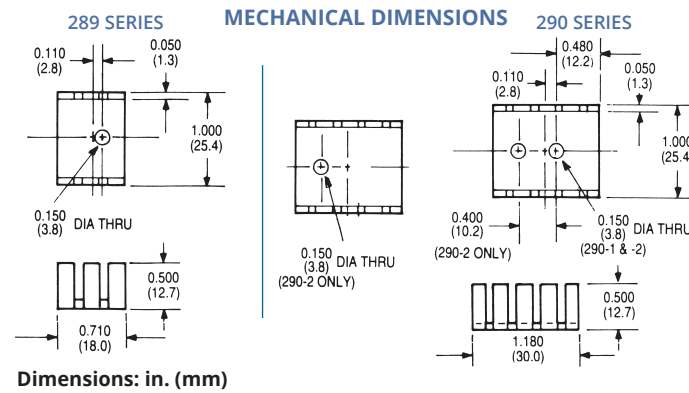

HIGH-PERFORMANCE SLIM PROFILE HEAT SINKS WITH INTEGRAL CLIPS

250 SERIES

Multiwatt

Standard P/N	Height Above PC Board in. (mm)	Footprint Dimensions in. (mm)	Mounting Configuration	Solderable Tab Options	Mounting Style	Thermal Performance at Typical Load	
						Natural Convection	Forced Convection
250-122AB	1.220 (31.0)	1.000 (25.4) x .500 (12.7)	Vert./Horiz.	No Tab	Clip	50°C @ 4W	3.7°C/W @ 400 LFM
250-122ABE-09	1.220 (31.0)	1.000 (25.4) x .500 (12.7)	Vertical	09	Clip	50°C @ 4W	3.7°C/W @ 400 LFM
250-122ABE-25	1.380 (35.1)	1.000 (25.4) x .500 (12.7)	Vertical	25	Clip	50°C @ 4W	3.7°C/W @ 400 LFM

Material: Aluminum, Black Anodized

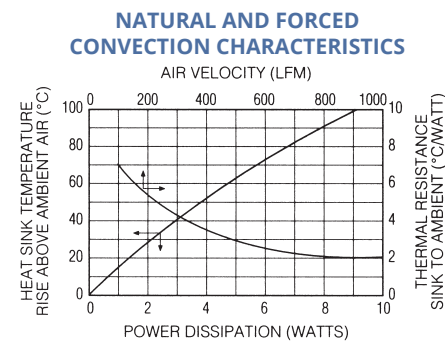
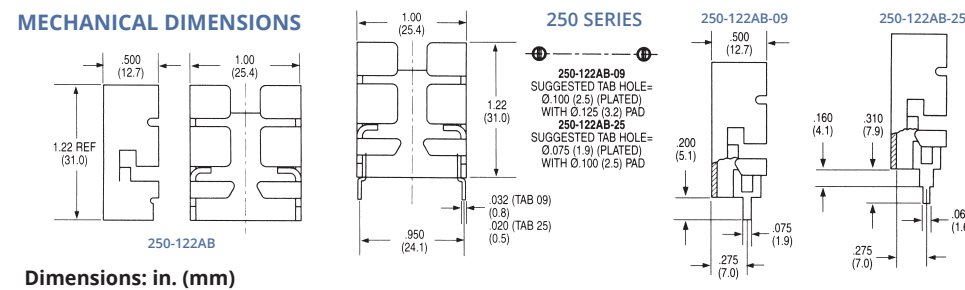

TO-220

HIGH-PERFORMANCE, HIGH-POWER VERTICAL MOUNT HEAT SINKS

237 & 252 SERIES

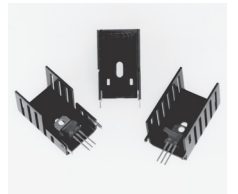

Standard P/N	Height Above PC Board in. (mm)	Footprint Dimensions in. (mm)	Mounting Configuration	Solderable Tab Options	Mounting Style	Thermal Performance at Typical Load	
						Natural Convection	Forced Convection
237-167AB2	1.675 (42.5)	1.000 (25.4) x 1.000 (25.4)	Vertical	2, Twisted	Clip/Mtg	Slot46°C @ 4W	4.5°C/W @ 200 LFM
237-167AB3	1.675 (42.5)	1.000 (25.4) x 1.000 (25.4)	Vertical	3, Twisted	Clip/Mtg	Slot46°C @ 4W	4.5°C/W @ 200 LFM
237-167ABE2-24	1.675 (42.5)	1.000 (25.4) x 1.000 (25.4)	Vertical	2, Solderable	Clip/Mtg	Slot46°C @ 4W	4.5°C/W @ 200 LFM
252-167AB2	1.675 (42.5)	1.000 (25.4) x 1.000 (25.4)	Vertical	2, Twisted	Clip/Mtg	Slot40°C @ 4W	4.5°C/W @ 200 LFM
252-167AB3	1.675 (42.5)	1.000 (25.4) x 1.000 (25.4)	Vertical	3, Twisted	Clip/Mtg	Slot40°C @ 4W	4.5°C/W @ 200 LFM
252-167ABE2-24	1.675 (42.5)	1.000 (25.4) x 1.000 (25.4)	Vertical	2, Solderable	Clip/Mtg	Slot40°C @ 4W	4.5°C/W @ 200 LFM

Order SpeedClips™ 2855C or 3305C separately for rapid component installation, lowering manufacturing costs.

Material: Aluminum, Black Anodized

MECHANICAL DIMENSIONS

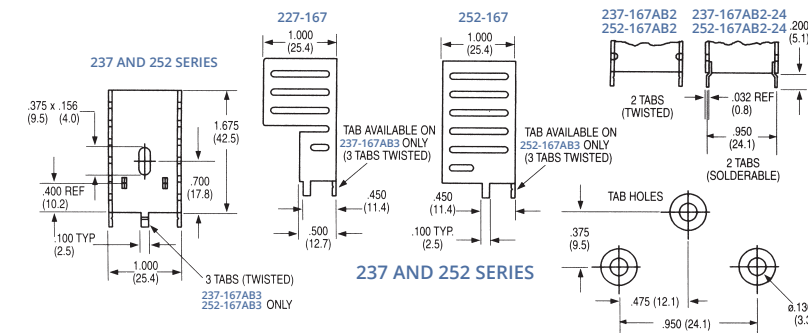

NATURAL AND FORCED CONVECTION CHARACTERISTICS

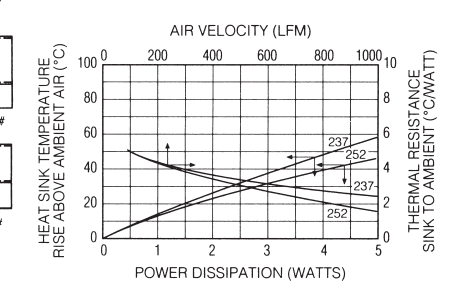

Dimensions: in. (mm)

291 SERIES

LABOR-SAVING CLIP-ON HEAT SINKS

TO-220



Designed for mounting horizontally or vertically on a circuit board, **291 Series** heat sinks employ a unique clip for attachment of TO-220 case styles. One type is available with a locking clip and one with a 0.140 in. (3.6) diameter mounting hole only.

Standard P/N	Vertical Height Above PC Board in. (mm)	Mounting Footprint Dimensions in. (mm)	Mounting Style	Thermal Performance at Typical Load		Weight lbs. (grams)
				Natural Convection	Forced Convection	
291-C236AB	0.860 (21.9)	1.100 (27.0) x 0.360 (9.1)	TO-220 (Clip)	80°C @ 2W	24°C/W @ 600 LFM	0.0026 (1.18)
291-H36AB	0.860 (21.9)	1.100 (27.0) x 0.360 (9.1)	TO-220 (Mtg. Hole)	68°C @ 2W	16°C/W @ 600 LFM	0.0026 (1.18)

Material: Aluminum, Black Anodized

MECHANICAL DIMENSIONS

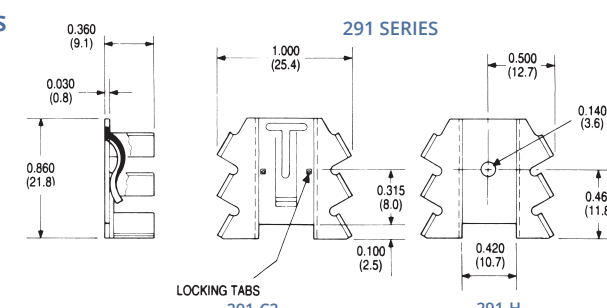

NATURAL AND FORCED CONVECTION CHARACTERISTICS

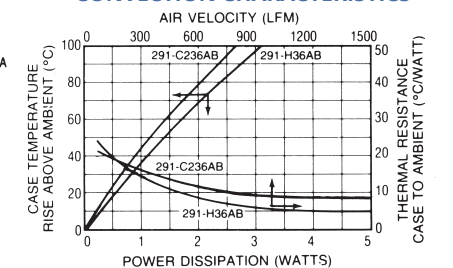

Dimensions: in. (mm)

BOARD LEVEL POWER SEMICONDUCTOR HEAT SINKS

286 SERIES

ALUMINUM AND COPPER LOW-COST WAVE-SOLDERABLE HEAT SINKS

TO-220

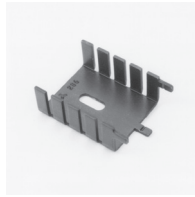

Efficient heat removal at low cost can be achieved by inserting the **286 Series** directly into pre-drilled circuit boards; scored mounting tabs may be bent after insertion to provide added stability. The **286 Series** can be wave-soldered directly to the board. See also 286DB Series on page 55.

Standard P/N	Height Above PC Board in. (mm)	Maximum Footprint in. (mm)	Material	Thermal Performance at Typical Load		Weight lbs. (grams)
				Natural Convection	Forced Convection	
286-AB	1.190 (30.2)	1.000 (25.4) x 0.500 (12.7)	Aluminum, Anodized	58°C @ 4W	7.4°C/W @ 200 LFM	0.0085 (3.86)
286-CBTE	1.190 (30.2)	1.000 (25.4) x 0.500 (12.7)	Copper, Black	58°C @ 4W	7.4°C/W @ 200 LFM	0.0250 (11.34)
286-CTE	1.190 (30.2)	1.000 (25.4) x 0.500 (12.7)	Copper, Tinned	58°C @ 4W	7.4°C/W @ 200 LFM	0.0250 (11.34)

Material: 286-AB style (aluminum, black anodized), 286-CBT style (copper, black paint tin tabs), and 286-CT style (copper, tinned).

MECHANICAL DIMENSIONS

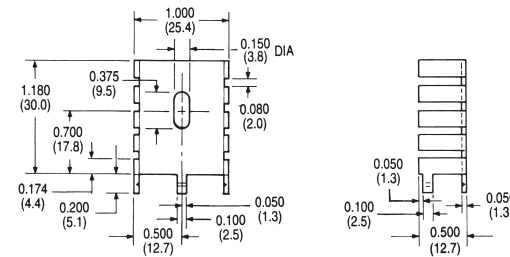

Dimensions: in. (mm)

NATURAL AND FORCED CONVECTION CHARACTERISTICS

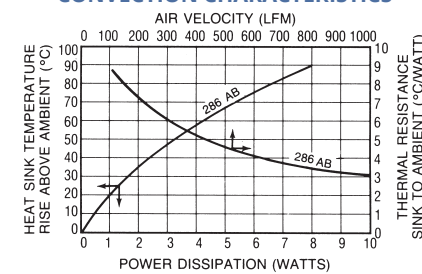

TO-220

WAVE-SOLDERABLE LOW-COST HEAT SINKS

287 SERIES

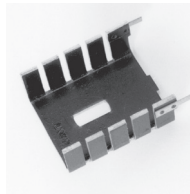

Mount these cost-effective TO-220 heat sinks vertically into pre-drilled printed circuit boards. Soldered, pre-tinned tabs can be wavesoldered directly to the board. A 0.375 in. (9.5 mm) mounting slot allows for correct positioning of TO-220 and similar semiconductor packages.

Standard P/N		Height Above PC Board in. (mm)	Maximum Footprint "A" in. (mm)	Thermal Performance at Typical Load		Weight lbs. (grams)
Mounting Slot	Mounting Hole			Natural Convection	Forced Convection	
287-1ABE	287-1ABH	1.180 (30.0)	1.000 (25.4) x 0.500 (12.7)	65°C @ 4W	7.8°C/W @ 200 LFM	0.0090 (4.08)
287-2ABE	287-2ABH	1.180 (30.0)	1.000 (25.4) x 1.000 (25.4)	55°C @ 4W	6.4°C/W @ 200 LFM	0.0140 (6.35)

Material: Aluminum, Black Anodized

MECHANICAL DIMENSIONS

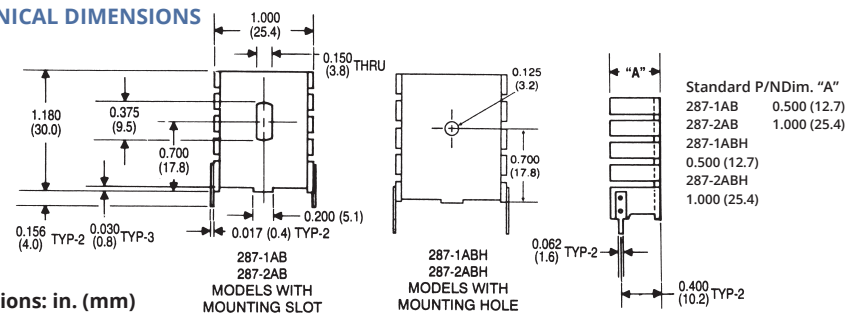

Dimensions: in. (mm)

NATURAL AND FORCED CONVECTION CHARACTERISTICS

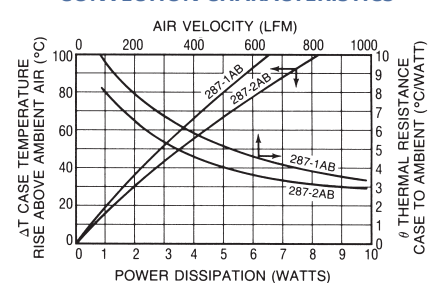

695 SERIES

SPACE-SAVING HEAT SINKS FOR SMALL STUD-MOUNTED DIODES

Stud-Mount



Mount and effectively heat sink small stud-mounted diodes with the **695 Series** space-saving heat sink type. Each unit is black anodized aluminum with an 0.200 in. (5.1) dia. mounting hole centered in the base. The folded fin design provides good heat dissipation for use where height is limited above the printed circuit board or base plate.

Standard P/N	Maximum Width in. (mm)	Height in. (mm)	Thermal Performance at Typical Load		Weight lbs. (grams)
			Natural Convection	Forced Convection	
695-1B	1.330 (33.8)	0.530 (13.7)	72°C @ 4.0W	5.2°C/W @ 400 LFM	0.008 (4.0)

MECHANICAL DIMENSIONS

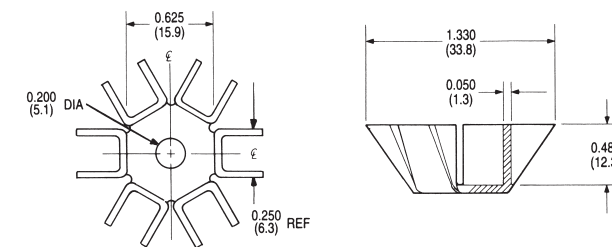

Dimensions: in. (mm)

NATURAL AND FORCED CONVECTION CHARACTERISTICS

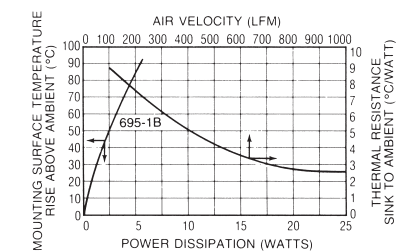

285 SC AND 330 SC SPEEDCLIPS™

285 & 330 SERIES



SpeedClips™ employ a locking safety tab for mounting. Must be ordered separately for these heat sink series. Use these SpeedClips™ with our 237, 240, and 252 Series heat sinks for the lowest production assembly time and cost. Order one SpeedClip™ for each heat sink purchased. Must be purchased with heat sinks.

Standard P/N	Nominal Installed Loading Force	For Use With Series	Material	Weight lbs. (grams)
285 SC	10 lbs	232, 237, 240, 252, 667	Carbon Steel	0.00053 (0.24)
330 SC	4 lbs	232, 237, 240, 252, 667	Stainless Steel	0.00074 (0.34)

MECHANICAL DIMENSIONS

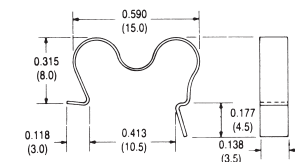

Speed Clip 330 SC
4 lb (17.8N)
Nominal Force Installed

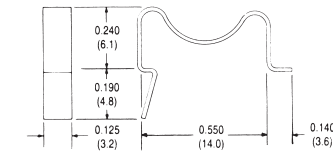

Speed Clip 285 SC
10 lb (44.5N)
Nominal Force Installed

Dimensions: in. (mm)

BOARD LEVEL POWER SEMICONDUCTOR HEAT SINKS

260 SERIES CUP CLIPS FOR TO-5 CASE STYLE SEMICONDUCTORS

TO-5



Characteristics	TO-5
Thermal Resistance – Epoxy Insulated	14° C/W
Breakdown Voltage – Epoxy Type (VAC), 60 Hz	500
Recommended Operating Voltage, AC or DC	
Clean Conditions: % Hipot Rating	50
Dusty Conditions: % Hipot Rating	30
Dirty Conditions: % Hipot Rating	10 to 20
Temperature Range — Continuous (C°)	-73/+149

Model	Depth of Tapped Base
260-4T5E	0.093 (2.36)
260-4TH5E	0.125 (3.18)

Thread Size: 4 = #4-40 UNC
6 = #6-32 UNC
Mounting Style: T = tapped
S = stud
P = plain

Base Style: H = hex
Semiconductor Case Style: 5 = TO-5
Insulation: E = epoxy

Standard P/N	Outline Dimension Insulation Type	L x W x I.D. in. (mm)	Weight lbs. (grams)	Case Style
260-4T5E	Epoxy Insulated	0.370 (9.4) x 0.380 (9.7) dia. x 0.290 (7.4)	0.0024 (1.09)	TO-5
260-4TH5E	Epoxy Insulated	0.400 (10.2) x 0.370 (9.4) hex. x 0.290 (7.4)	0.0031 (1.41)	TO-5
260-6SH5E	Epoxy Insulated	0.557 (14.1) x 0.370 (9.4) hex. x 0.290 (7.4)	0.0037 (1.68)	TO-5

Materials and Finish: Cups – beryllium copper, black ebonol "C"; Bases – brass, black ebonol "C"

Base Mounting Configurations — TO-5
Plain Type — Epoxy bonded, or used with #4 pan head screws.
Tapped Base — #4-40 UNC screw (not supplied) fits tapped hole. Care should be taken not to use too long a screw, which could short against the semiconductor case. For correct screw lengths:
 Correct Screw Length (L) = Depth of Base + Panel Thickness + Washer Thickness
Stud Mounting Base. #6-32 UNC. Nuts and washers not supplied. Stud hole must be slightly countersunk to ensure flat mounting.

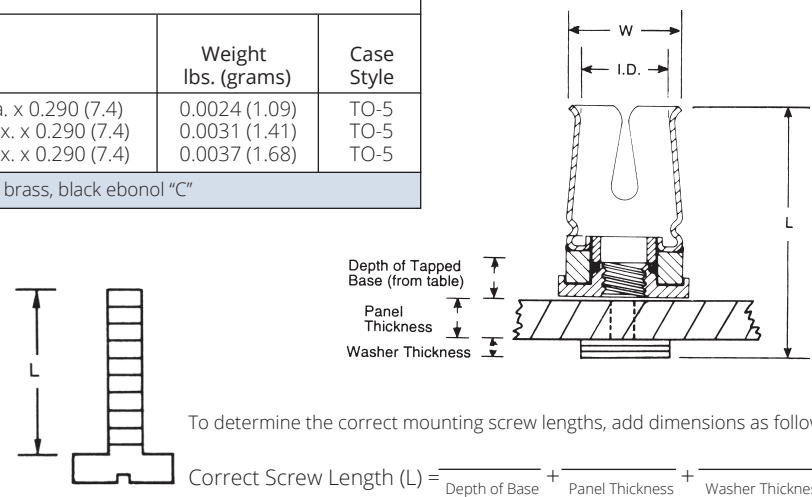

EPOXY INSULATED FOR TO-5 260 SERIES

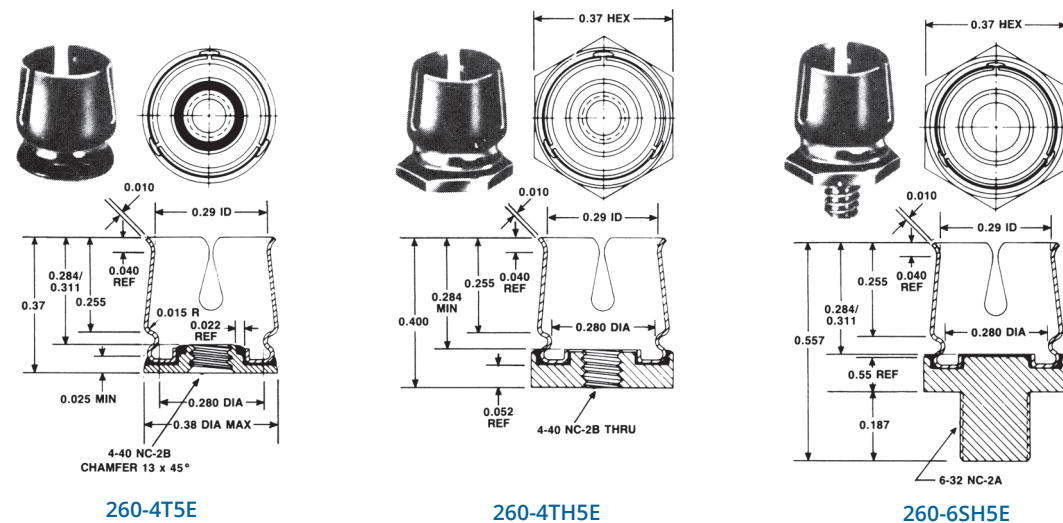

Diodes

THERMAL LINKS FOR FUSED GLASS DIODES

258 SERIES

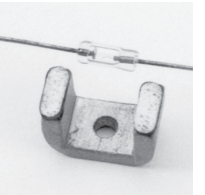

The thermal resistance from diode leads to chassis or heat sink is 12°C/watt, when unit is mounted with TYPE 120 Joint Compound. If a 10°C/watt chassis or sink to ambient impedance is available, the thermal resistance from the diode leads to ambient is reduced from about 150°C/watt to 22°C/watt.

Standard P/N	Dimensions in. (mm)	Material	Finish	Weight lbs. (grams)
258	0.500 (12.7) x 0.250 (6.4) x 0.340 (8.6)	Aluminum	DeltaCoate™ 151 on all surfaces except solder pads and base	0.0018 (0.82)

MECHANICAL DIMENSIONS

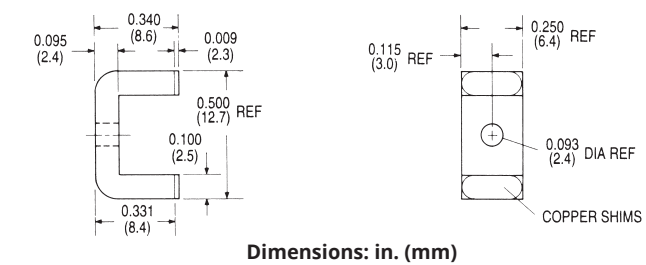

634 SERIES

SLIM PROFILE UNIDIRECTIONAL FIN VERTICAL MOUNT HEAT SINK

TO-220 and TO-218

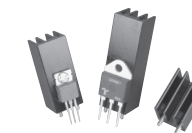

These slim profile unidirectional fin heat sinks offer users two assembly alternatives for vertically mounting TO-220 and TO-218 components. Models are available with or without wave-solderable pins on 0.40 in. (10.2) centers, making them ideal for a variety of applications where quick assembly is needed and space is at a premium.

Standard P/N		Height Above PC Board in. (mm)	Footprint Dimensions in. (mm)	Weight lbs. (grams)
Plain Pin	Without Pin			
634-10ABEP	634-10AB	1.000 (25.4)	0.640 (16.26) x 0.640 (16.26)	0.016 (7.48)
634-15ABEP	634-15AB	1.500 (38.1)	0.640 (16.26) x 0.640 (16.26)	0.025 (11.21)
634-20ABEP	634-20AB	2.000 (50.8)	0.640 (16.26) x 0.640 (16.26)	0.033 (14.95)

Material: Aluminum, Black Anodized.

MECHANICAL DIMENSIONS

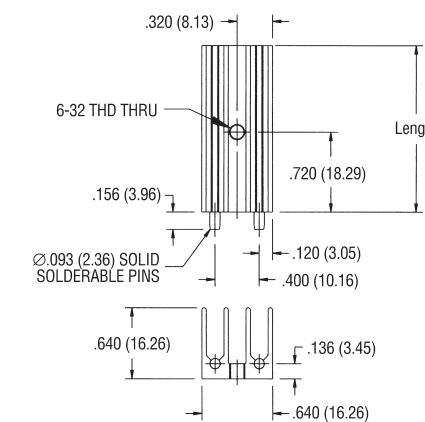

TYPICAL THERMAL PERFORMANCE FOR 634-15ABP

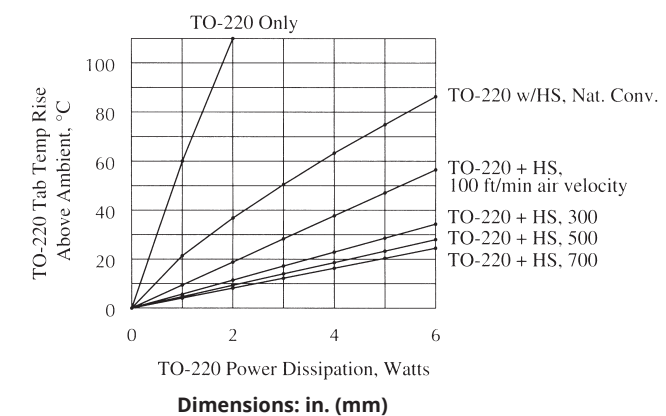

- NOTES:**
1. Thermal compound is assumed between device and heat sink.
 2. Tab temp with longer heat sink (634-20ABP) will typically be about 15% cooler. Tab temp with shorter heat sink (634-10ABP) will typically be about 25% higher.

BOARD LEVEL POWER SEMICONDUCTOR HEAT SINKS



292 SERIES

HEAT SINK FOR SINGLE TO-92

TO-92

Power semiconductors packaged in a TO-92 style plastic case can be cooled effectively at little additional cost with the addition of the 292-AB heat sink. The 292-AB is effective over the typical power range of such devices.

Standard P/N	Height Above PC Board in. (mm)	Overall Fin Width in. (mm)	Thermal Performance Natural Convection	Finish	Weight lbs. (grams)
292-AB	0.750 (19.1)	0.600 (15.3)	0.225°C/W @ 0.250 W	Black Anodized	0.00049 (0.22)

Material: Aluminum, Black Anodized

MECHANICAL DIMENSIONS

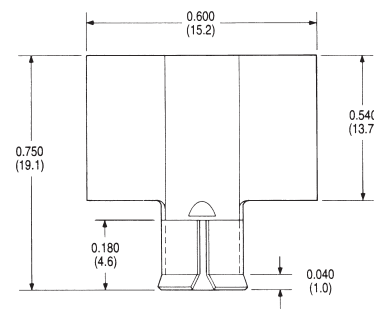

Dimensions: in. (mm)

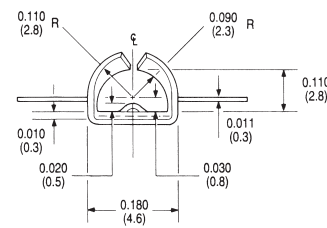

NATURAL AND FORCED CONVECTION CHARACTERISTICS

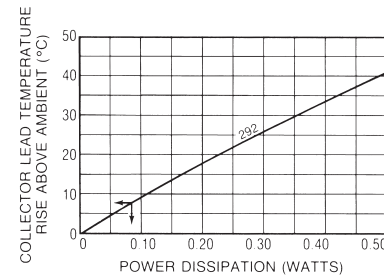

HIGH-EFFICIENCY HEAT SINKS FOR VERTICAL BOARD MOUNTING

637 SERIES

TO-220

Wave-solderable pins on 1 in. centers for vertical mounting on printed circuit boards. Maximum semiconductor package width 0.625 in. (15.9). Use this heat sink where weight and board space occupied must be minimized. Refer to the Accessory products section for thermal interface materials, thermal compounds, and other accessories products.

Standard P/N	Height Above PC Board "A" in. (mm)	Maximum Footprint in. (mm)	Thermal Performance at Typical Load		Weight lbs. (grams)
			Natural Convection	Forced Convection	
637-10ABEP	1.000 (25.4)	1.375 (34.9) x 0.500 (12.7)	76°C @ 6W	5.8°C/W @ 200 LFM	0.023 (10.43)
637-15ABEP	1.500 (38.1)	1.375 (34.9) x 0.500 (12.7)	65°C @ 6W	5.5°C/W @ 200 LFM	0.035 (15.88)
637-20ABEP	2.000 (50.8)	1.375 (34.9) x 0.500 (12.7)	55°C @ 6W	4.7°C/W @ 200 LFM	0.050 (22.68)
637-25ABEP	2.500 (63.5)	1.375 (34.9) x 0.500 (12.7)	48°C @ 6W	4.2°C/W @ 200 LFM	0.062 (28.12)

Material: Aluminum, Black Anodized

MECHANICAL DIMENSIONS

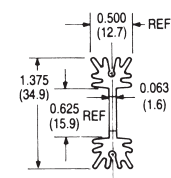

Dimensions: in. (mm)

637 SERIES (EXTRUSION PROFILE 5183)

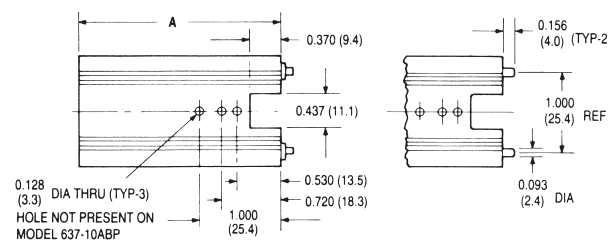

NATURAL AND FORCED CONVECTION CHARACTERISTICS

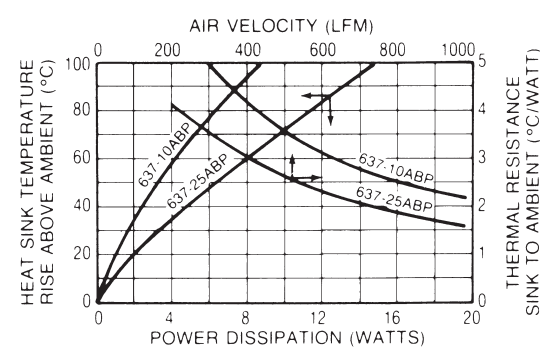

wakefield-vette.com

LABOR-SAVING SPEEDCLIP™ HEAT SINKS FOR VERTICAL BOARD MOUNTING

667 SERIES

TO-220

Excellent performance, choice of wave-solderable plain pins (PP-Type) or wave-solderable hex-shaped standoff pins (SP-Type), and reduced assembly cost.

Standard P/N Standoff Pin	Standard P/N Plain Pin	Height Above PC Board "A" in. (mm)	Maximum Footprint in. (mm)	Thermal Performance at Typical Load		Weight lbs. (grams)
				Natural Convection	Forced Convection	
667-10ABESP	667-10ABPP	1.000 (25.4)	1.375 (34.9) x 0.500 (12.7)	76°C @ 6W	5.8°C/W @ 200 LFM	0.0240 (11.0)
667-15ABESP	667-15ABPP	1.500 (38.1)	1.375 (34.9) x 0.500 (12.7)	66°C @ 6W	5.5°C/W @ 200 LFM	0.0340 (15.6)
667-20ABESP	667-20ABPP	2.000 (50.8)	1.375 (34.9) x 0.500 (12.7)	58°C @ 6W	4.7°C/W @ 200 LFM	0.0460 (21.0)
667-25ABESP	667-25ABPP	2.500 (63.5)	1.375 (34.9) x 0.500 (12.7)	48°C @ 6W	4.2°C/W @ 200 LFM	0.0580 (26.2)

Order 330 SC or 285 SC SpeedClip™ separately.

Wave-solderable pins. **Material:** Aluminum, Black Anodized

MECHANICAL DIMENSIONS

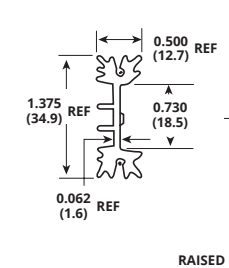

Dimensions: in. (mm)

667 SERIES (EXTRUSION PROFILE 8073)

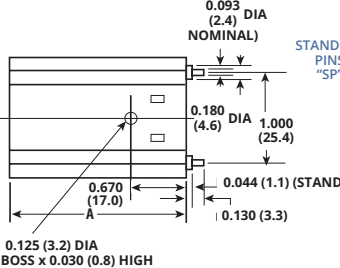

Dimensions: in. (mm)

NATURAL AND FORCED CONVECTION CHARACTERISTICS

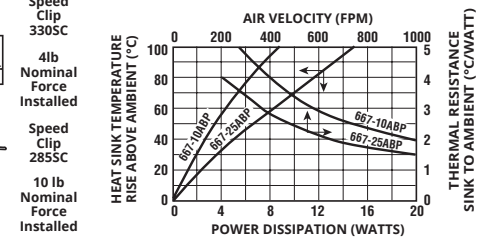

626 & 627 SERIES

HIGH-EFFICIENCY HEAT SINKS FOR VERTICAL BOARD MOUNTING

TO-220 and TO-218

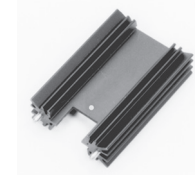

Standard P/N	Standard P/N	Height Above PC Board "A" in. (mm)	Maximum Footprint in. (mm)	Thermal Performance at Typical Load	
				Natural Convection	Forced Convection
626-10ABEP	627-10ABP	1.000 (25.4)	1.375 (34.9) x .500 (12.7)	76°C @ 6W	5.8°C/W @ 200 LFM
626-15ABEP	627-15ABP	1.500 (38.1)	1.375 (34.9) x .500 (12.7)	65°C @ 6W	5.5°C/W @ 200 LFM
626-20ABEP	627-20ABP	2.000 (50.8)	1.375 (34.9) x .500 (12.7)	55°C @ 6W	4.7°C/W @ 200 LFM
626-25ABEP	627-25ABP	2.500 (63.5)	1.375 (34.9) x .500 (12.7)	48°C @ 6W	4.2°C/W @ 200 LFM

Wave-solderable pins. **Material:** Aluminum, Black Anodized

MECHANICAL DIMENSIONS

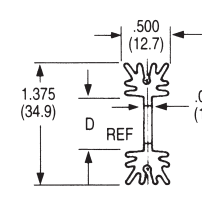

Dimensions: in. (mm)

626 AND 627 SERIES

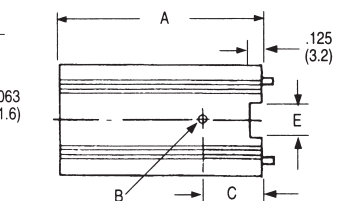

Dimensions: in. (mm)

NATURAL AND FORCED CONVECTION CHARACTERISTICS

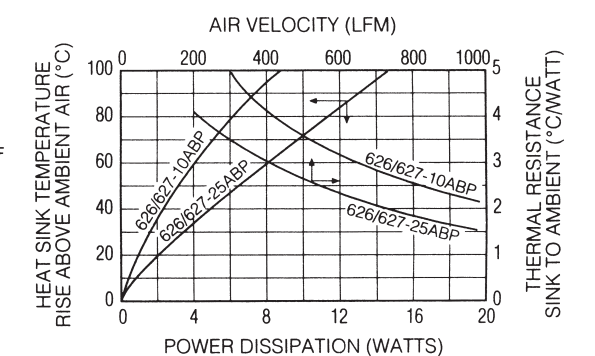

Series	Type Device	Hole Diameter "B"	Hole Height "C"	Webb Width "D"	Notch Width "E"	Extrusion Profile
626	TO-218	.144 (3.7)	.850 (21.6)	.660 (16.8)	.540 (13.7)	8420
627	TO-220	.128 (3.3)	.720 (18.3)	.625 (15.9)	.437 (11.1)	5183

Contact us: (603) 635-2800

BOARD LEVEL POWER SEMICONDUCTOR HEAT SINKS

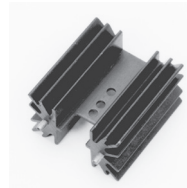

647 SERIES

HIGH-PERFORMANCE HEAT SINKS FOR VERTICAL BOARD MOUNTING

TO-220

Wave-solderable pins on 1 in. centers for vertical mounting of larger devices on printed circuit boards. Maximum semiconductor package width: 0.625 (15.9). Refer to the Accessory Products section for thermal interface materials, 126 Series silicone-free thermal compounds, and other accessories products.

Standard P/N	Height Above PC Board "A" in. (mm)	Maximum Footprint in. (mm)	Thermal Performance at Typical Load		Weight lbs. (grams)
			Natural Convection	Forced Convection	
647-10ABEP	1.000 (25.4)	1.650 (41.9) x 1.000 (25.4)	42°C @ 6W	3.8°C/W @ 200 LFM	0.055 (24.95)
647-15ABEP	1.500 (38.1)	1.650 (41.9) x 1.000 (25.4)	37°C @ 6W	3.5°C/W @ 200 LFM	0.075 (34.02)
647-175ABEP	1.750 (44.5)	1.650 (41.9) x 1.000 (25.4)	34°C @ 6W	3.3°C/W @ 200 LFM	0.090 (40.82)
647-20ABEP	2.000 (50.8)	1.650 (41.9) x 1.000 (25.4)	31°C @ 6W	3.1°C/W @ 200 LFM	0.104 (47.17)
647-25ABEP	2.500 (63.5)	1.650 (41.9) x 1.000 (25.4)	25°C @ 6W	2.8°C/W @ 200 LFM	0.125 (56.70)

Material: Aluminum, Black Anodized

MECHANICAL DIMENSIONS

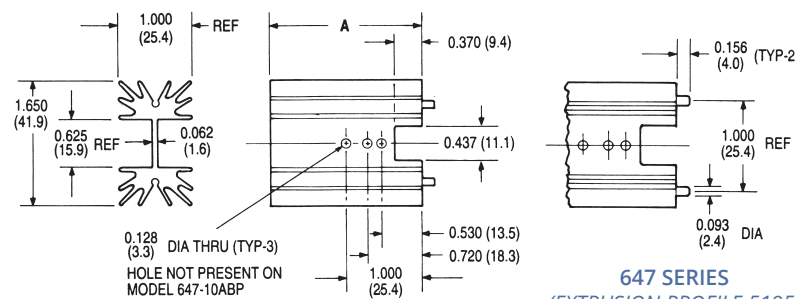

Dimensions: in. (mm)

NATURAL AND FORCED CONVECTION CHARACTERISTICS

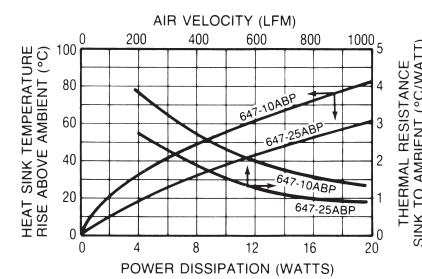

647 SERIES
(EXTRUSION PROFILE 5195)

HIGH-PERFORMANCE HEAT SINKS FOR VERTICAL BOARD MOUNTING

657 SERIES

TO-218; TO-247; TO-220

Standard P/N	Height Above PC Board "A" in. (mm)	Maximum Footprint in. (mm)	Thermal Performance at Typical Load		Weight lbs (grams)
			Natural Convection	Forced Convection	
657-10ABEP	1.000 (25.4)	1.650 (41.9) x 1.000 (25.4)	41°C @ 6W	3.7°C/W @ 200 LFM	0.0515 (23.36)
657-15ABEP	1.500 (38.1)	1.650 (41.9) x 1.000 (25.4)	38°C @ 6W	3.3°C/W @ 200 LFM	0.0760 (34.60)
657-20ABEP	2.000 (50.8)	1.650 (41.9) x 1.000 (25.4)	32°C @ 6W	2.9°C/W @ 200 LFM	0.1030 (47.00)
657-25ABEP	2.500 (63.5)	1.650 (41.9) x 1.000 (25.4)	25°C @ 6W	2.7°C/W @ 200 LFM	0.1250 (57.00)

Wave-solderable pins. Material: Aluminum, Black Anodized

MECHANICAL DIMENSIONS

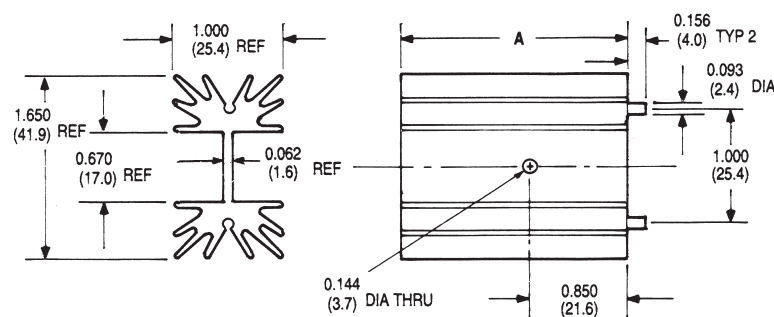

Dimensions: in. (mm)

NATURAL AND FORCED CONVECTION CHARACTERISTICS

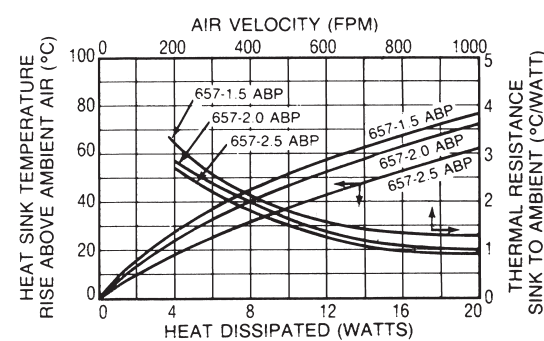

657 SERIES
(EXTRUSION PROFILE 6533)

HIGH-PERFORMANCE NOTCHED HEAT SINKS FOR VERTICAL BOARD MOUNTING

657 SERIES

TO-218; TO-247; TO-220

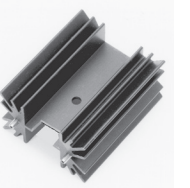

Standard P/N	Height Above PC Board "A" in. (mm)	Maximum Footprint in. (mm)	Thermal Performance at Typical Load	
			Natural Convection	Forced Convection
657-10ABEPN	1.000 (25.4)	1.650 (41.9) x 1.000 (25.4)	41°C @ 6W	3.7°C/W @ 200 LFM
657-15ABEPN	1.500 (38.1)	1.650 (41.9) x 1.000 (25.4)	38°C @ 6W	3.3°C/W @ 200 LFM
657-20ABEPN	2.000 (50.8)	1.650 (41.9) x 1.000 (25.4)	32°C @ 6W	2.9°C/W @ 200 LFM
657-25ABEPN	2.500 (63.5)	1.650 (41.9) x 1.000 (25.4)	25°C @ 6W	2.7°C/W @ 200 LFM

Wave-solderable pins. Material: Aluminum, Black Anodized

MECHANICAL DIMENSIONS

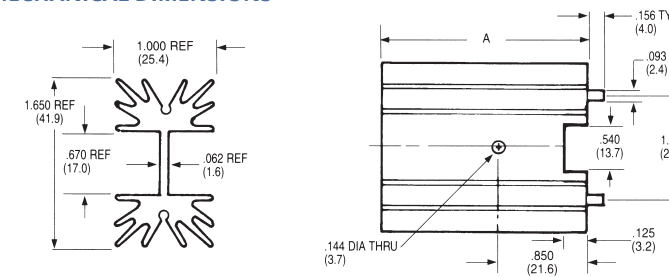

Dimensions: in. (mm)

NATURAL AND FORCED CONVECTION CHARACTERISTICS

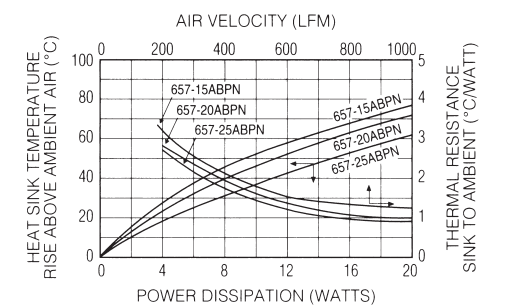

657 SERIES
(EXTRUSION PROFILE 6533)

HIGH-PERFORMANCE HEAT SINKS WITH SPEEDCLIPS™ FOR VERTICAL BOARD MOUNTING

TO-218; TO-247; TO-220

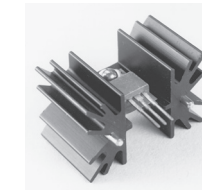

657 SERIES

Standard P/N	Height Above PC Board "A" in. (mm)	Maximum Footprint in. (mm)	Thermal Performance at Typical Load	
			Natural Convection	Forced Convection
657-10ABEPSC	1.000 (25.4)	1.650 (41.9) x 1.000 (25.4)	41°C @ 6W	3.7°C/W @ 200 LFM
657-15ABEPSC	1.500 (38.1)	1.650 (41.9) x 1.000 (25.4)	38°C @ 6W	3.3°C/W @ 200 LFM
657-20ABEPSC	2.000 (50.8)	1.650 (41.9) x 1.000 (25.4)	32°C @ 6W	2.9°C/W @ 200 LFM
657-25ABEPSC	2.500 (63.5)	1.650 (41.9) x 1.000 (25.4)	25°C @ 6W	2.7°C/W @ 200 LFM

Wave-solderable pins. Material: Aluminum, Black Anodized

MECHANICAL DIMENSIONS

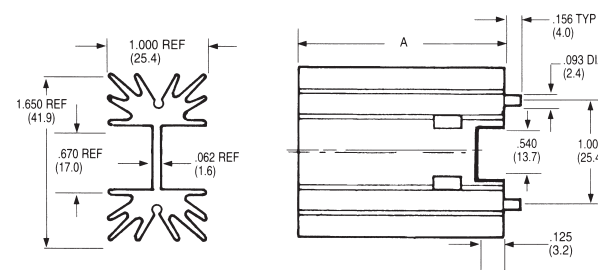

Dimensions: in. (mm)

SPEEDCLIP™ INCLUDED IN ORDER

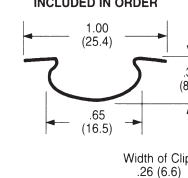

657 SERIES
(EXTRUSION PROFILE 6533)

NATURAL AND FORCED CONVECTION CHARACTERISTICS

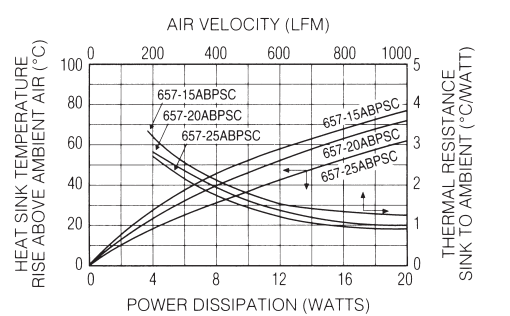

BOARD LEVEL POWER SEMICONDUCTOR HEAT SINKS

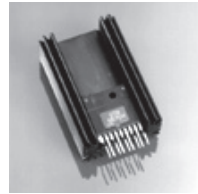

677 SERIES

HIGH-PERFORMANCE, HIGH-POWER HEAT SINKS FOR VERTICAL BOARD MOUNTING

TO-218; TO-220; TO-247;
15-Lead Multiwatt

Standard P/N	Height Above PC Board "A" in. (mm)	Maximum Footprint in. (mm)	Thermal Performance at Typical Load	
			Natural Convection	Forced Convection
677-10ABEP	1.000 (25.4)	1.650 (41.9) x 1.000 (25.4)	52°C @ 6W	3.1°C/W @ 200 LFM
677-15ABEP	1.500 (38.1)	1.650 (41.9) x 1.000 (25.4)	46°C @ 6W	2.8°C/W @ 200 LFM
677-20ABEP	2.000 (50.8)	1.650 (41.9) x 1.000 (25.4)	40°C @ 6W	2.5°C/W @ 200 LFM
677-25ABEP	2.500 (63.5)	1.650 (41.9) x 1.000 (25.4)	35°C @ 6W	2.2°C/W @ 200 LFM

Wave-solderable pins. Material: Aluminum, Black Anodized

MECHANICAL DIMENSIONS

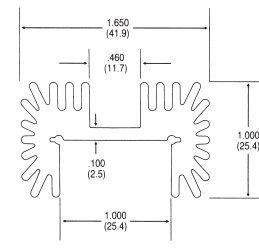

Dimensions: in. (mm)

677 SERIES
(EXTRUSION PROFILE 8719)

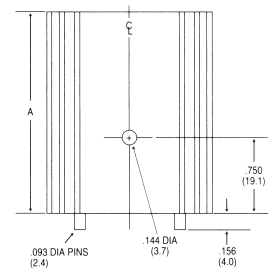

NATURAL AND FORCED CONVECTION CHARACTERISTICS

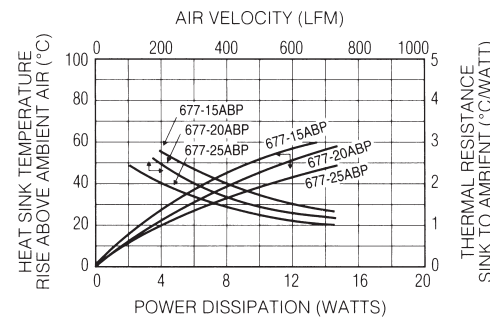

TO-3; TO-66; TO-220

HIGHEST EFFICIENCY/LOWEST UNIT COST HEAT SINKS

690 SERIES

These low-cost heat sinks provide the most power dissipation at the lowest unit cost and are available in three standard types to mount and cool one TO-3 or TO-66 metal power semiconductor type or two plastic package TO-220 power semiconductor types. For higher power semiconductor, the 690 Series can dissipate up to 20 watts while maintaining a mounting surface temperature rise above ambient air temperature of no more than 91°C.



Standard P/N	Height Above PC Board in. (mm)	Outline Dimensions in. (mm)	Thermal Performance at Typical Load		Semiconductor Mounting Hole Pattern	Weight lbs. (grams)
			Natural Convection	Forced Convection		
690-3B	1.310 (33.3)	1.860 (47.2)-sq	44°C @ 7.5W	2.0°C/W @ 400 LFM	(1) TO-3	0.0700 (31.75)
690-66B	1.310 (33.3)	1.860 (47.2)-sq	44°C @ 7.5W	2.0°C/W @ 400 LFM	(1) TO-66	0.0700 (31.75)
690-220B	1.310 (33.3)	1.860 (47.2)-sq	44°C @ 7.5W	2.0°C/W @ 400 LFM	(2) TO-220	0.0700 (31.75)

Material: Aluminum, Black Anodized

MECHANICAL DIMENSIONS

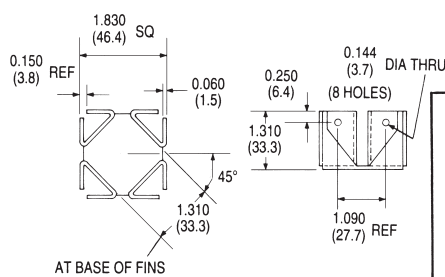

Dimensions: in. (mm)

SEMICONDUCTOR MOUNTING HOLES

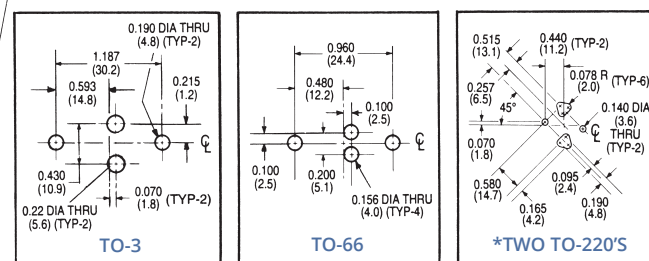

NATURAL AND FORCED CONVECTION CHARACTERISTICS

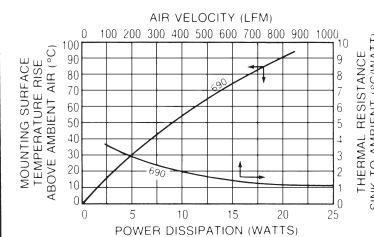

TO-3; TO-220

MAXIMUM EFFICIENCY OMNIDIRECTIONAL HEAT SINKS

680 SERIES

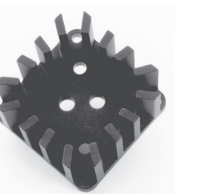

Achieve optimum natural convection cooling per unit volume occupied above the printed circuit board for TO-3 (one semiconductor package per heat sink) or for two TO-220 style cases, when this low-cost heat sink is used. Any mounting attitude will provide free circulation of air in natural convection applications. These 680 Series heat sinks can also be specified without any semiconductor mounting hole pattern by specifying suffix "K" (Example: 680-5K).

Standard P/N	Height Above PC Board "A" in. (mm)	Horizontal Mounting Footprint Dimensions in. (mm)	Thermal Performance at Typical Load		Semiconductor Mounting Hole Pattern	Weight lbs. (grams)
			Natural Convection	Forced Convection		
680-5A	0.500 (12.7)	1.810 (46.0)-sq	70°C @ 7.5W	3.0°C/W @ 400 LFM	(1) TO-3	0.0700 (31.75)
680-75A	0.750 (19.1)	1.810 (46.0)-sq	58°C @ 7.5W	2.4°C/W @ 400 LFM	(1) TO-3	0.0900 (40.82)
680-10A	1.000 (25.4)	1.810 (46.0)-sq	52°C @ 7.5W	2.0°C/W @ 400 LFM	(1) TO-3	0.0980 (44.45)
680-125A	1.250 (31.8)	1.810 (46.0)-sq	45°C @ 7.5W	1.5°C/W @ 400 LFM	(1) TO-3	0.1100 (49.90)
680-5220	0.500 (12.7)	1.810 (46.0)-sq	70°C @ 7.5W	3.0°C/W @ 400 LFM	(2) TO-220	0.0700 (31.75)
680-75220	0.750 (19.1)	1.810 (46.0)-sq	58°C @ 7.5W	2.4°C/W @ 400 LFM	(2) TO-220	0.0900 (40.82)
680-10220	1.000 (25.4)	1.810 (46.0)-sq	52°C @ 7.5W	2.0°C/W @ 400 LFM	(2) TO-220	0.0980 (44.45)
680-125220	1.250 (31.8)	1.810 (46.0)-sq	45°C @ 7.5W	1.5°C/W @ 400 LFM	(2) TO-220	0.1100 (49.90)

Material: Aluminum, Black Anodized

MECHANICAL DIMENSIONS

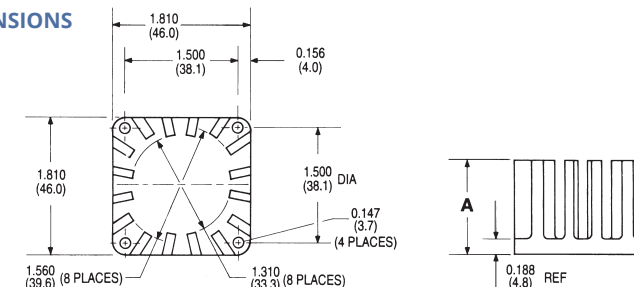

NATURAL AND FORCED CONVECTION CHARACTERISTICS

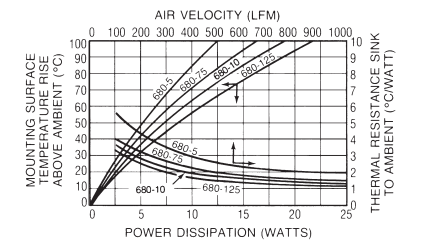

SEMICONDUCTOR MOUNTING HOLES

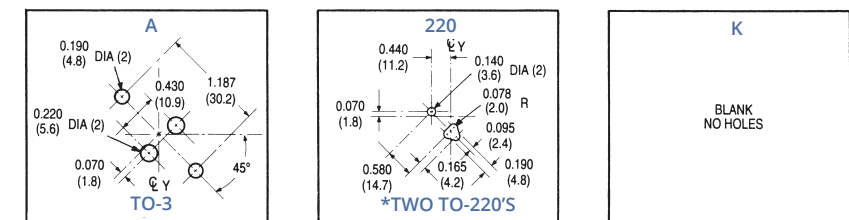

Dimensions: in. (mm)

*Only one hole pattern of two is shown. Hole patterns are symmetrical about the center lines.

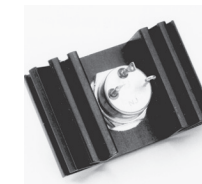

601 & 603 SERIES

LOW-HEIGHT HEAT SINKS

DO-4/DO-5 Diodes

Use these low-height heat sinks on printed circuit board applications for TO-66 power semiconductors and DO-4 and DO-5 diodes, where close board-to-board spacing and efficient heat dissipation are required. The 601 and 603 Series may also be attached to enclosure panels or brackets using isolation hardware where necessary.

Standard P/N	Footprint Dimensions in. (mm)	Height in. (mm)	Mounting Hole Dia. in. (mm)	Thermal Performance at Typical Load		Weight lbs. (grams)
				Natural Convection	Forced Convection	
601E	2.000 (50.8) x 1.250 (31.8)	0.562 (14.3)	0.200 (5.1)	52°C @ 5.0W	4.5°C/W @ 175 LFM	0.0500 (22.68)
601F	2.000 (50.8) x 1.250 (31.8)	0.562 (14.3)	0.270 (6.9)	52°C @ 5.0W	4.5°C/W @ 175 LFM	0.0500 (22.68)
601K	2.000 (50.8) x 1.250 (31.8)	0.562 (14.3)	None	52°C @ 5.0W	4.5°C/W @ 175 LFM	0.0500 (22.68)
603K	2.000 (50.8) x 2.000 (50.8)	0.562 (14.3)	None	41°C @ 5.0W	4.0°C/W @ 175 LFM	0.0810 (36.74)

Material: Aluminum Alloy, Black Anodized

BOARD LEVEL POWER SEMICONDUCTOR HEAT SINKS

601 & 603 SERIES

LOW-HEIGHT HEAT SINKS

DO-4/DO-5 Diodes

MECHANICAL DIMENSIONS

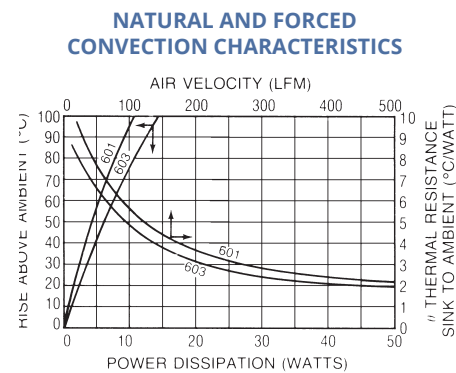
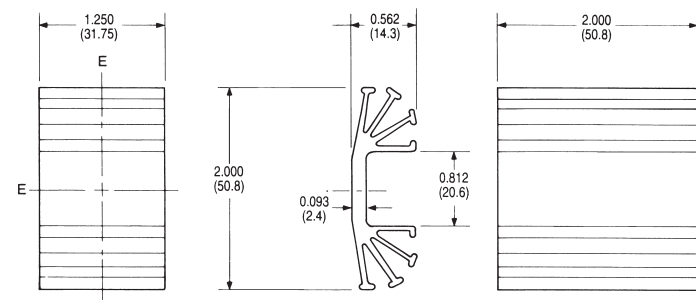

SEMICONDUCTOR MOUNTING HOLES

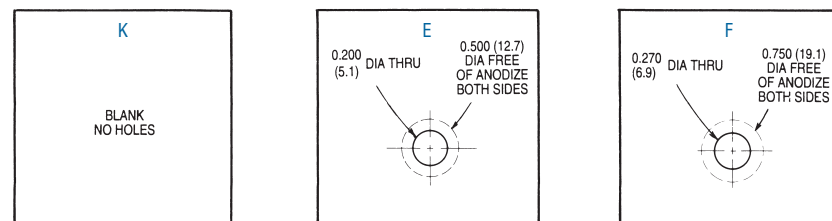

Dimensions: in. (mm)

E&F available on 601 Series only as a standard product.

MAXIMUM PERFORMANCE NATURAL CONVECTION HEAT SINK FOR ALL METAL-CASE SEMICONDUCTORS

TO-3

641 SERIES

Available with a standard TO-3 mounting hole pattern predrilled for cost-effective mounting in limited-height applications, the 641 Series provides maximum performance in natural convection with an optimized heat sink surface area. The 641K type with an open channel area of 1.300 in. (33.0) and no predrilled mounting holes can be adapted to meet mounting requirements for most metal case power semiconductor types.

Standard P/N	Outline Dimensions in. (mm)	Height in. (mm)	Mounting Hole Pattern	Thermal Performance at Typical Load		Weight lbs. (grams)
				Natural Convection	Forced Convection	
641A	4.125 (104.8) x 3.000 (76.2)	1.000 (25.4)	(1) TO-3	36°C @ 15W	0.9°C/W @ 250 LFM	0.2900 (131.54)
641K	4.125 (104.8) x 3.000 (76.2)	1.000 (25.4)	None	36°C @ 15W	0.9°C/W @ 250 LFM	0.2900 (131.54)

Material: Aluminum Alloy, Black Anodized.

MECHANICAL DIMENSIONS

641 SERIES (EXTRUSION PROFILE 1371)

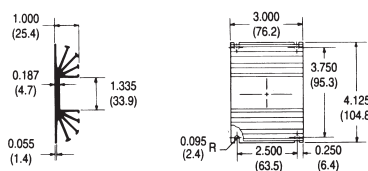

Dimensions: in. (mm)

SEMICONDUCTOR MOUNTING HOLES

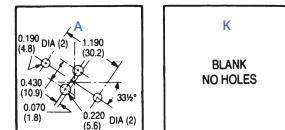

NATURAL AND FORCED CONVECTION CHARACTERISTICS

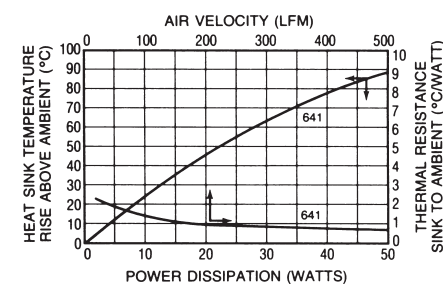

UNIVERSAL 678 SERIES VERTICAL HEAT SINK FOR POWER DEVICES

678-39-S & 678-39-C



Wakefield-Vette introduces **Universal 678 series**, high performance, low cost and versatile heat sink with screw or clip for all kinds of standard packages. This type of heat sink provides both vertical and horizontal mounting options on PCB to accommodate natural and forced convection cooling method.

SPECIFICATIONS

- **Heat Sink:** Aluminum Alloy 6063-T5 or Equivalent with either degreased or black anodized finish
- **Spring Clip:** Music Wire, Per ASTM A228 with bright nickel plating
- **Solder Foot:** Cold-rolled Steel, Per ASTM A-366 with pure tin over copper strike. RoHS compliant.
- **Insulator (Optional):** t-Global H48-1, L37-3F and H48-6S. The thickness of the insulating material not to exceed 10 mil (0.01").

FEATURES AND BENEFITS

- **Minimum assembly cost and labor** - Spring Clips make the mounting holes and fasteners obsolete in assembly operations & reduce costs.
- **Design Flexibility** - Universal mountable and "one fits all" give designers total freedom to fit their packaging designs with ideal device pack style and to orient the heat sink to meet their power dissipations with optimized cooling method. (see page 7 of data sheet).

Part Number	Description	Length	Width	Thermal Resistance @ Forced Air Flow
678-39-S	Universal Heat Sink for TO Devices w/Screw Hole, Black Anodize	1.520" (38.61mm)	2.362" (60.00mm)	0.6°C/W @ 600 LFM
678-39-C	Universal Heat Sink for TO Devices w/ Clip, Black Anodize	1.520" (38.61mm)	2.362" (60.00mm)	0.6°C/W @ 600 LFM

MECHANICAL DIMENSIONS

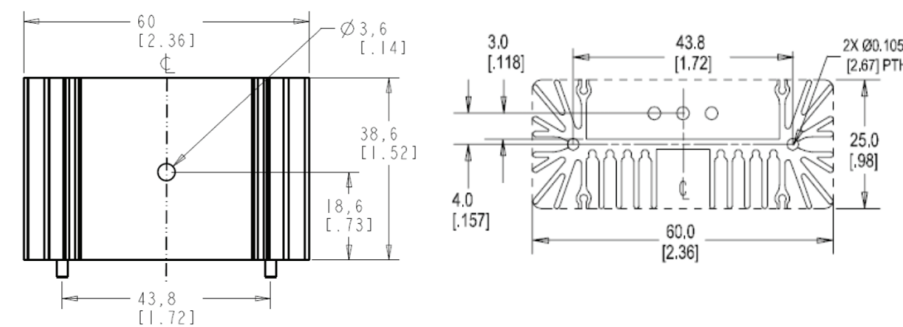

THERMAL PERFORMANCE

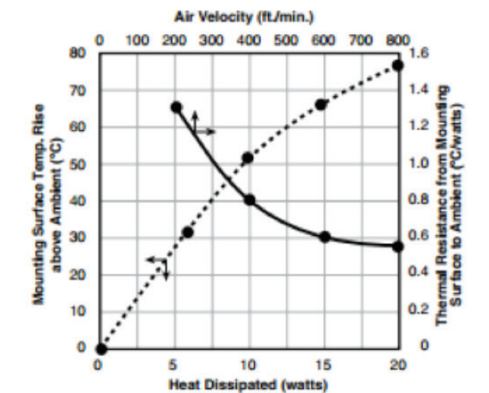

ONE HEAT SINK FOR ALL PACKAGES

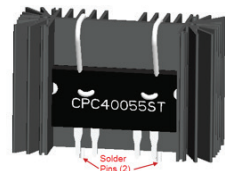

CPC40055ST PACKAGE

Board level – 2 solder pins Natural convection – Vertical Spring Clip

CPC1998J PACKAGE

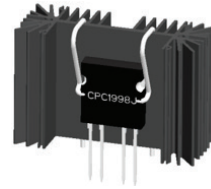

Board level – 2 solder pins Natural convection – Vertical Spring Clip

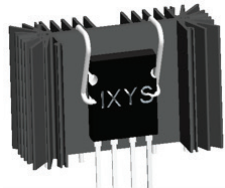

CPC1968 AND TO-264 PACKAGE

Board level – 2 solder pins Natural convection – Vertical Spring Clip

L4970A PACKAGE

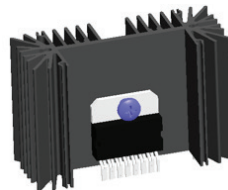

Board level – 2 solder pins Natural convection – Vertical Screw attachment

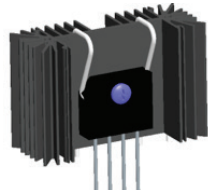

KBU PACKAGE

Board level – 2 solder pins Natural convection – Vertical Spring Clip

TO-247 AND TO-220 PACKAGE

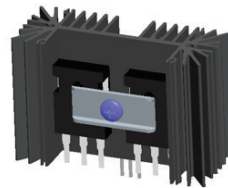

Board level – 2 solder pins Natural convection – Vertical Screw attachment or Spring Clip

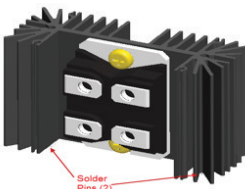

SOT-227 PACKAGE

System level – 2 screws Natural convection – Vertical

MOUNTAIN SERIES HEAT SINKS FOR TO-264, TO-247 DEVICES

MTN-264-27



Wakefield-Vette's **Mountain Series Heat Sinks** are high performance, low cost, configurable, scalable and compact with a matrix clip system for TO220, TO-247, TO-264 and other standard packages. This type powerful heat sink provides easiest assembly, largest surface areas, smallest space occupation and all-in-one solution. The power dissipations can be easily increased simply by extending the fin height on each side of the heat sink, while keeping the heat sink height and PCB layout the same. It is the ideal type of heat sink for high power density and small size (1U or 2U) electronic packaging with forced convection cooling.

FEATURES AND BENEFITS

- **Minimum assembly cost and labor** - Spring Clips make the mounting holes and fasteners obsolete in assembly operations and reduce costs.
- **Maximum Thermal Transfer** - Maximum surface area per unit volume, efficient cooling fins & consistent mounting force reduces thermal resistance.
- **Maximum Repeatability** - Constant spring force over repeated assembly/disassembly.
- **Maximum Reliability** - Resilient spring action locks electronic component in place. Fewer parts in assembly and no fasteners and washers required. Prevent short circuit by eliminating metal particles generated from hardware or thread tapping.

Part Number	Description	Type	Package Cooled	Attachment Method	Length	Width	Height Off Base (Height of Fin)	Thermal Resistance @ Forced Air Flow	Material	Material Finish
MTN-264-27	Heat Sink w/ Two Clips for TO-247 TO-264	Top Mount	TO-247 and TO-264	Clip and PC Pin	1.06" (27mm)	1.740" (44.3mm)	1.56" (39.5mm)	5.5°C/W @ 18 Watts	Aluminum	Black Anodized

MECHANICAL DIMENSIONS

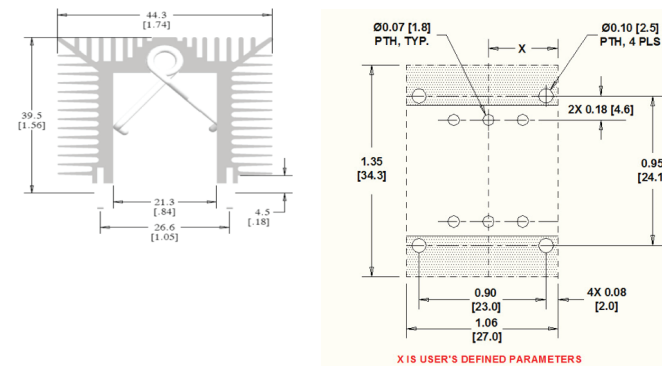

THERMAL RESISTANCE

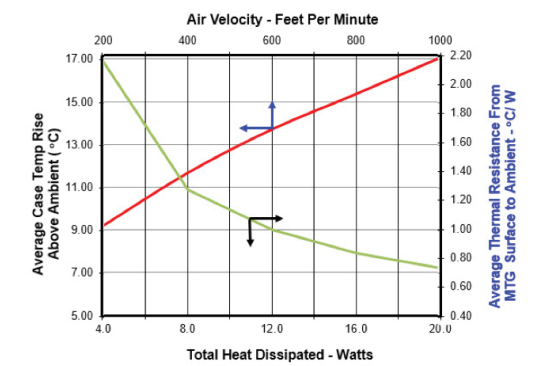

MOUNTAIN SERIES HEAT SINKS FOR TO-264, TO-247 DEVICES



MTN-264-55

Wakefield-Vette's **Mountain Series Heat Sinks** are high performance, low cost, configurable, scalable and compact with a matrix clip system for TO220, TO-247, TO-264 and other standard packages. This type powerful heat sink provides easiest assembly, largest surface areas, smallest space occupation and all-in-one solution. The power dissipations can be easily increased simply by extending the fin height on each side of the heat sink, while keeping the heat sink height and PCB layout the same. It is the ideal type of heat sink for high power density and small size (1U or 2U) electronic packaging with forced convection cooling.

FEATURES AND BENEFITS

- Minimum assembly cost and labor** - Spring Clips make the mounting holes and fasteners obsolete in assembly operations and reduce costs.
- Maximum Thermal Transfer** - Maximum surface area per unit volume, efficient cooling fins & consistent mounting force reduces thermal resistance.
- Maximum Repeatability** - Constant spring force over repeated assembly/disassembly.
- Maximum Reliability** - Resilient spring action locks electronic component in place. Fewer parts in assembly and no fasteners and washers required. Prevent short circuit by eliminating metal particles generated from hardware or thread tapping.

Part Number	Description	Type	Package Cooled	Attachment Method	Length	Width	Height Off Base (Height of Fin)	Thermal Resistance @ Forced Air Flow	Material	Material Finish
MTN-264-55	Heat Sink w/ Two Clips for TO-247 TO-264	Top Mount	TO-247 and TO-264	Clip and PC Pin	2.17" (55.11mm)	1.740" (44.3mm)	1.56" (39.5mm)	3.7°C/W @ 18 Watts	Aluminum	Black Anodized

MECHANICAL DIMENSIONS

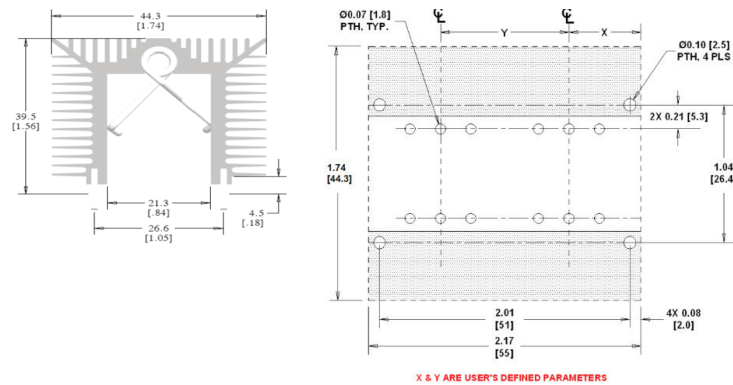

THERMAL RESISTANCE

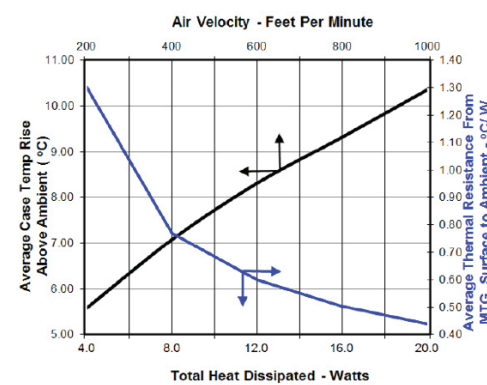

omniKLIP™ SERIES HEAT SINK W/ CLIP(S) FOR TO-DEVICES



HEAT SINKS OMNI-CLIP-18-L SERIES

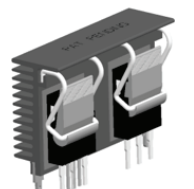

omniKlip™

The Wakefield- Vette **omniKlip Heat Sink Series** are a configurable and patented (Pat. Pending) high performance, low cost and compact solutions for TO-220, TO-247 and TO-264 , or similar packages. This powerful heat sink provides tool and fixture free assembly operation, largest surface areas and smallest space occupation. It is the ideal type of heat sink for high power density and small size (1U or 2U) electronic packaging with forced convection cooling.

SPECIFICATIONS

- Heat Sink:** Aluminum Alloy 6063-T5 or Equivalent with black anodized finish.
- Spring Clip:** Music Wire, Per ASTM A228 with bright nickel plating
- Solder Foot:** Cold-rolled Steel, Per ASTM A-366 with pure tin over copper strike. RoHS compliant.

FEATURES AND BENEFITS

- Minimum assembly cost and labor** - Spring Clips make the mounting holes, fasteners, tools and fixtures obsolete in assembly operations & reduce costs.
- Maximum Repeatability** - Constant spring force over repeated assembly/disassembly
- Maximum Reliability** - Resilient spring action locks electronic component in place. Fewer parts in assembly and no fasteners and washers required. Prevent short circuit by eliminating metal particles generated from hardware or thread tapping
- Design Flexibility** - Maximum flexibility for dynamic device locations and power up grading. "Configure-to-Fit" gives designers total freedom to configure heat sink needed to fit their dynamic design environments.

Wkv Part Number	Description	Related Clip	Package Cooled	Length	Width	Height Off Base (Height of Fin)
OMNI-UNI-18-25	OmniKlip Heat Sink, 18mm wide, 25mm long, black anodized for TO-247 & TO-264	OMNI-UC	TO-247, TO-264	0.984" (25.00mm)	1.500" (38.10mm)	0.710" (18.03mm)
OMNI-UNI-18-50	OmniKlip Heat Sink, 18mm wide, 50mm long, black anodized for TO-247 & TO-264	OMNI-UC	TO-247, TO-264	1.969" (50.00mm)	1.500" (38.10mm)	0.710" (18.03mm)
OMNI-UNI-18-75	OmniKlip Heat Sink, 18mm wide, 75mm long, black anodized for TO-247 & TO-264	OMNI-UC	TO-247, TO-264	2.95" (75.00mm)	1.500" (38.10mm)	0.710" (18.03mm)
OMNI-220-18-25-1C	OmniKlip Heat Sink w/1 clip, 18mm wide, 25mm long, black anodized for TO-220		TO-220	0.984" (25.00mm)	1.500" (38.10mm)	0.710" (18.03mm)
OMNI-220-18-50-2C	OmniKlip Heat Sink w/2 clips, 18mm wide, 50mm long, black anodized for TO-220		TO-220	1.969" (50.00mm)	1.500" (38.10mm)	0.710" (18.03mm)
OMNI-220-18-75-3C	OmniKlip Heat Sink w/3 clips, 18mm wide, 75mm long, black anodized for TO-220		TO-220	2.95" (75.00mm)	1.500" (38.10mm)	0.710" (18.03mm)

MECHANICAL DIMENSIONS

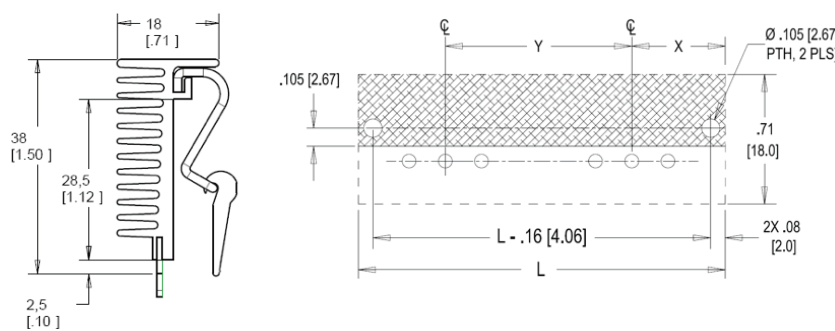

THERMAL PERFORMANCE (OMNI-UNI-18) TWO TO-247 DEVICES WITH SIL-PAD 900s L = 500mm[2.0"]

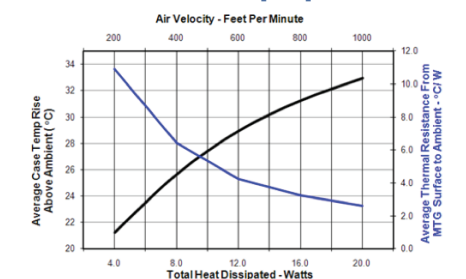

OmniKLIP™ SERIES HEAT SINK W/ CLIP(S) FOR TO-DEVICES

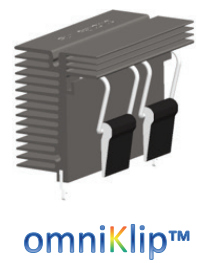

OMNI-UNI-32-L SERIES HEAT SINKS



WkV Part Number	Description	Related Cross Sell Part	Package Cooled	Shape	Length	Width	Height Off Base (Height of Fin)
OMNI-UNI-32-58	OmniKlip Heat Sink for 2 universal 2 clips, 32mm wide, 58mm long, black anodized for any TO except TO-220	OMNI-UC, OMNI-220C	TO-247, TO-264	Rectangular, Fins	2.28" (58mm)	1.25" (32mm)	1.62" (46.3mm)

MECHANICAL DIMENSIONS

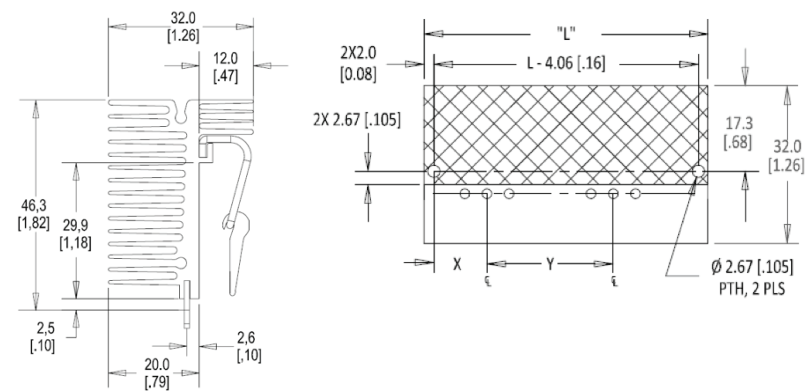

THERMAL PERFORMANCE

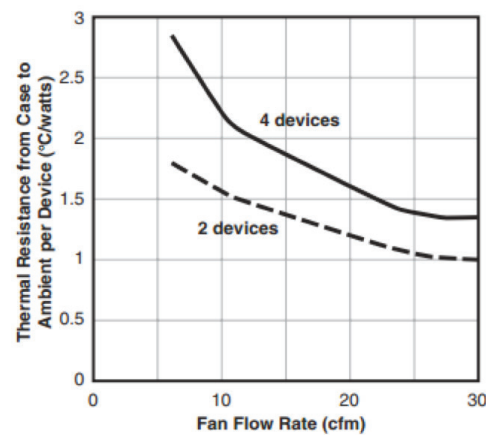

OMNIKLIPS™



Part Number	Description
OMNI-UC	Universal Clip for omniKlip Heat Sink for any TO except TO220
OMNI-220C	Clip for omniKlip Heat Sink for TO 220

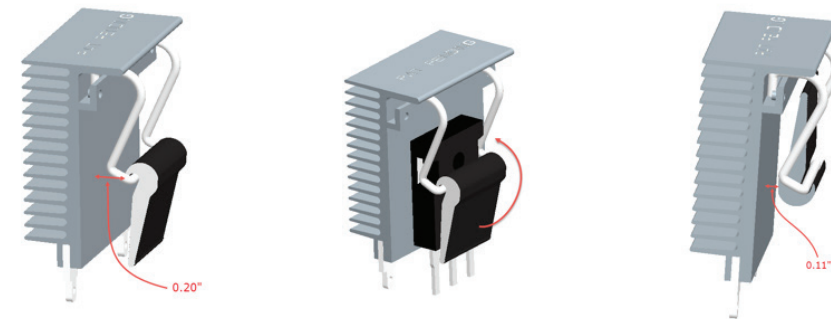

Universal Clip mechanism is rotating the bar by 180°. The eccentric circle will raise 0.09". This deformation will exert the force on the components.



HEAT SINKS OMNI-UNI-41-L SERIES

WkV Part Number	Description	Related Cross Sell Part	Package Cooled	Shape	Length	Width	Height Off Base (Height of Fin)
OMNI-UNI-41-75	OmniKlip Heat Sink for 2 universal 2 clips, 41mm wide, 75mm long, black anodized for any TO except TO-220	OMNI-UC, OMNI-220C	TO-247, TO-264	Rectangular, Fins	2.95" (75mm)	1.61" (41mm)	1.62" (46.3mm)

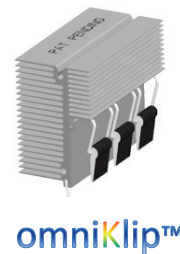

MECHANICAL DIMENSIONS

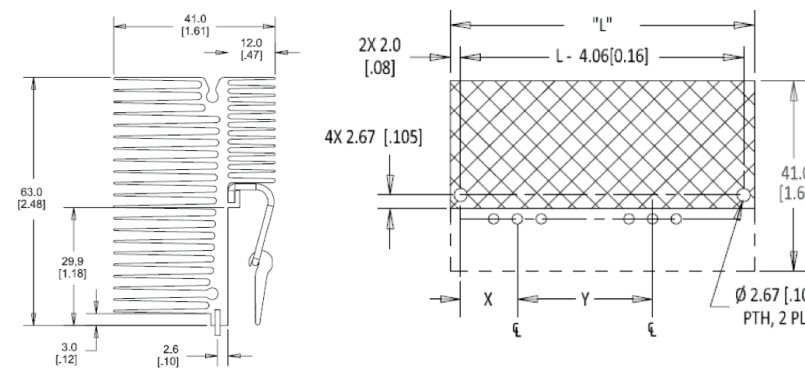

THERMAL PERFORMANCE

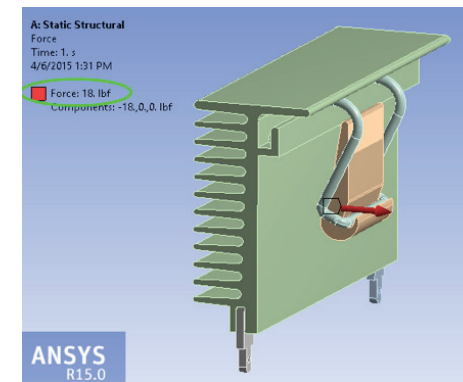
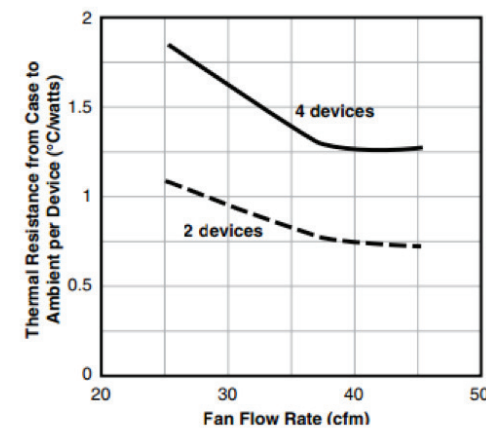

omniKlip assembly model in ANSYS, with 18 lbf load applied to the clip

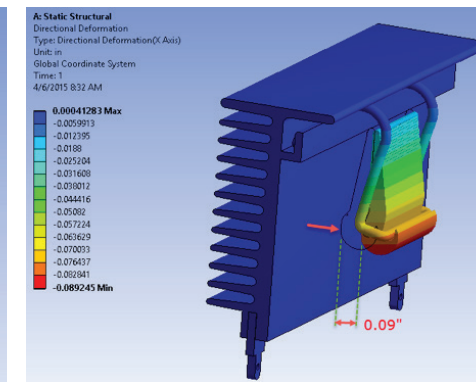

Under the 18 lbf, the clip deformed 0.09" from its original position to the final

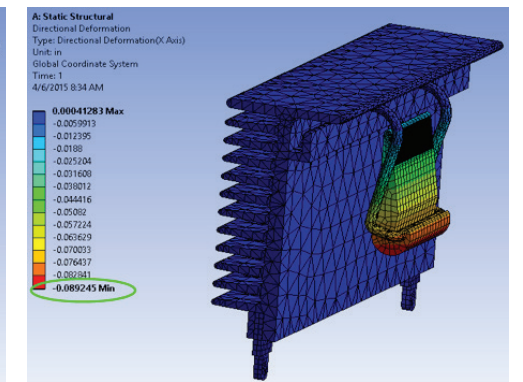

Directional deformation plot as shown.

With the FEA analysis and simulation, the force applied to the TO-series components will be at least 18 lbs.

ADDITIONAL CONFIGURATIONS

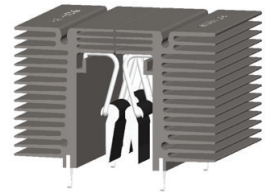

OMNI-UNI-32-L SERIES FACE TO FACE MOUNTING (SPACE SAVER)

omniKlip™

BACK TO BACK MOUNTING WITH 40MM FAN

OMNI-UNI-32-L SERIES

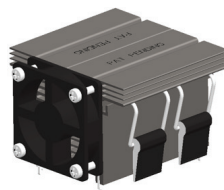

omniKlip™

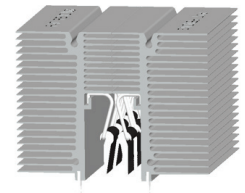

OMNI-UNI-41-L SERIES FACE TO FACE MOUNTING (SPACE SAVER)

omniKlip™

BACK TO BACK MOUNTING WITH 60MM FAN

OMNI-UNI-41-L SERIES

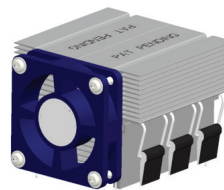

omniKlip™

X-ON Electronics

Largest Supplier of Electrical and Electronic Components

Click to view similar products for [Heat Sinks](#) category:

Click to view products by [Wakefield](#) manufacturer:

Other Similar products are found below :

[657-20ABPNE](#) [73452PPBA](#) [A22-4026](#) [120-1873-007](#) [218-40CTE3](#) [231-69PAB-15V](#) [231-75PAB-13V](#) [231-75PAB-15V](#) [253-122ABE-22](#)
[PSC22CB](#) [295-2](#) [CLP212SG](#) [D10100-28](#) [BDN183CBA01](#) [3-21053-4](#) [TX0506-1B](#) [LAE66A3CB](#) [511-3U](#) [73381PPBA](#) [73403PPBA](#) [8191-](#)
[E40](#) [510-12M](#) [529802B00000](#) [D10650-40T5](#) [6225B-MT6G](#) [ATS-54310K-C2-R0](#) [648-51AB](#) [657-20ABPESC](#) [679-25AG](#) [FK 212 CB SA](#)
[FK225 SA L1](#) [241404B91203G](#) [6801G](#) [680-5K](#) [7106DG/TR](#) [SK145 37 5STSTO220](#) [7109DG/TR](#) [TS-11042-CY](#) [S14K35G3S5](#) [8924G](#)
[7717-133DAP](#) [7717-26DAP](#) [4509](#) [SW25-4G](#) [CLP-215](#) [CLP-207](#) [D20850-40-T2](#) [APF30-30-10CB/A01](#) [V8508E](#) [268-85CTE](#)