

.275 EXPANDED MIN
[6.99]

VIEW OF ASSEMBLY EXPANDED

.120 [3.05] MAX SCREW ADVANCEMENT
(.300 [7.62] MAX WITH V OPTION)

.125
[3.18]

ASSY LENGTH
(SEE P/N CODE SHEET 2)

.20
[5.1]

.225 MAX
[5.72 MAX]

VIEW OF ASSEMBLY RELAXED

.220
[5.59]

.220
[5.59]

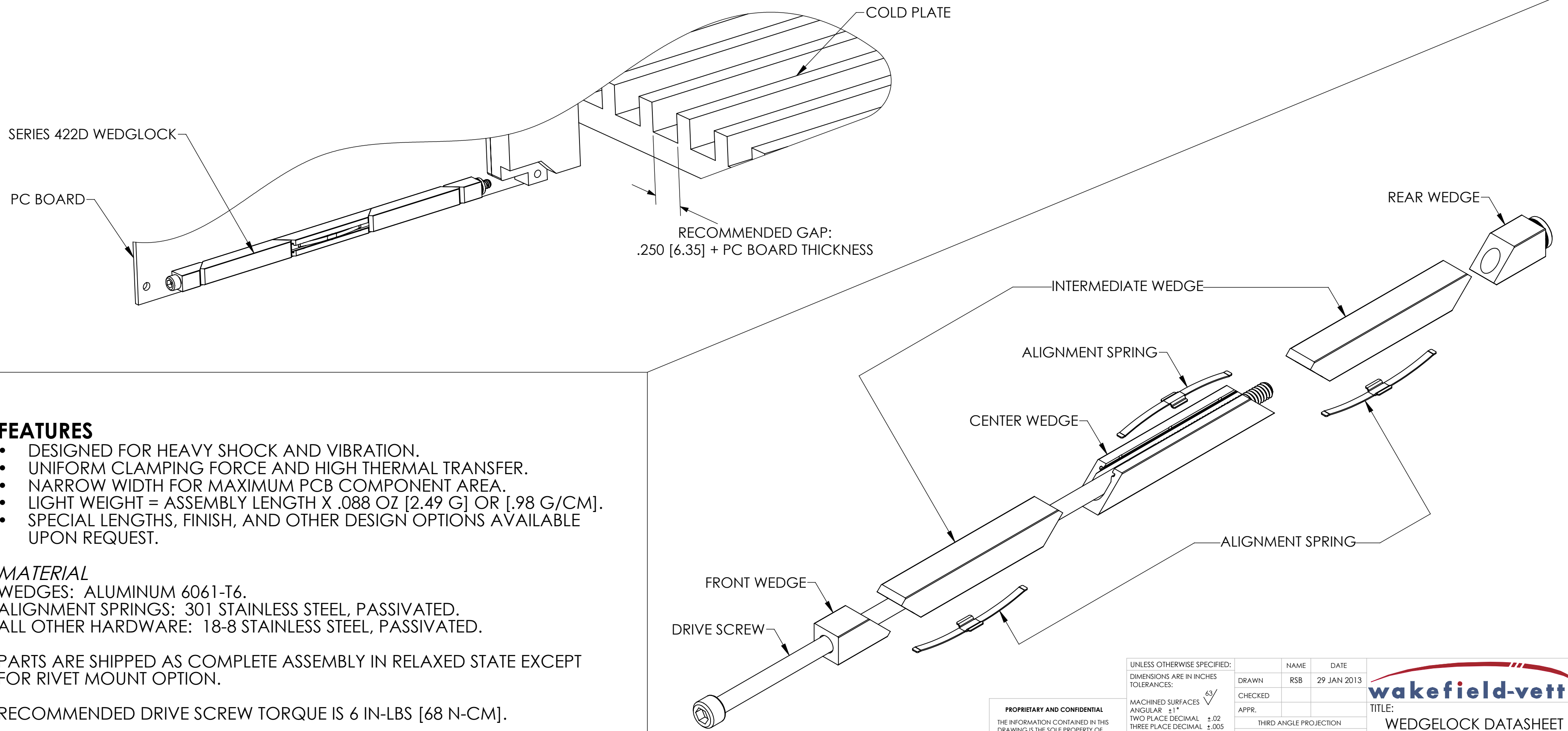

FEATURES

- DESIGNED FOR HEAVY SHOCK AND VIBRATION.
- UNIFORM CLAMPING FORCE AND HIGH THERMAL TRANSFER.
- NARROW WIDTH FOR MAXIMUM PCB COMPONENT AREA.
- LIGHT WEIGHT = ASSEMBLY LENGTH X .088 OZ [2.49 G] OR [.98 G/CM].
- SPECIAL LENGTHS, FINISH, AND OTHER DESIGN OPTIONS AVAILABLE UPON REQUEST.

MATERIAL

WEDGES: ALUMINUM 6061-T6.
ALIGNMENT SPRINGS: 301 STAINLESS STEEL, PASSIVATED.
ALL OTHER HARDWARE: 18-8 STAINLESS STEEL, PASSIVATED.

PARTS ARE SHIPPED AS COMPLETE ASSEMBLY IN RELAXED STATE EXCEPT FOR RIVET MOUNT OPTION.

RECOMMENDED DRIVE SCREW TORQUE IS 6 IN-LBS [68 N-CM].

PROPRIETARY AND CONFIDENTIAL
THE INFORMATION CONTAINED IN THIS DRAWING IS THE SOLE PROPERTY OF WAKEFIELD-VETTE. ANY REPRODUCTION IN PART OR AS A WHOLE WITHOUT THE WRITTEN PERMISSION OF WAKEFIELD-VETTE IS PROHIBITED.
MATERIAL: SEE PART DETAILS
FINISH: SEE FINISH TABLE

UNLESS OTHERWISE SPECIFIED:
DIMENSIONS ARE IN INCHES
TOLERANCES:
MACHINED SURFACES
ANGULAR ±1°
TWO PLACE DECIMAL ±.02
THREE PLACE DECIMAL ±.005
INTERPRET GEOMETRIC TOLERANCING PER: ASME Y-14.5M
DO NOT SCALE DRAWING

DRAWN	NAME	DATE
CHECKED	RSB	29 JAN 2013
APPR.		
THIRD ANGLE PROJECTION		
CAGE CODE	3E7UB	

wakefield-vette

TITLE: WEDGLOCK DATASHEET
.220 X .220 PROFILE

SIZE	DWG. NO.	REV
C	422D-DS	02/13

SCALE: NONE SHEET 1 OF 2

[LLL] LENGTH TABLE		
ASSY LENGTH [LLL]	[H] MTG X	[C] OPTION X/2
480 - 749	.900	.450
750 - 849	1.900	.950
850 & UP	2.900	1.450

OTHER LENGTHS AVAILABLE UPON REQUEST

[H] MOUNTING TABLE	
DASH NO	DESCRIPTION
A	NO MOUNTING HOLES
R	$\phi .068 / .073$ THRU $\phi .156 \times \downarrow .16$ $100^\circ \times \phi .140$
T	#0-80 UNF-2B THREADS
S	#2-56 UNC-2B THREADS
U	M2 X .4-6H THREADS
M	M2.5 X .45-6H THREADS

[F] FINISH TABLE	
DASH NO	DESCRIPTION
A	NONE
C	CHEM FILM PER MIL-DTL-5541, CLASS 1A, TYPE I (CLEAR)
G	CHEM FILM PER MIL-DTL-5541, CLASS 1A, TYPE I (GOLD)
B	BLACK ANODIZE PER MIL-A-8625, TYPE II, CLASS 2
H	HARD BLACK ANODIZE PER MIL-A-8625, TYPE III, CLASS 2
N	NICKEL PLATE PER QQ-N-290, CLASS 1, GRADE G, BRIGHT
E	ELECTROLESS NICKEL PER MIL-C-26074, CLASS 4, GRADE B, BRIGHT
T	TRIVALENT CHEM FILM PER MIL-DTL-5541, CLASS 1A, TYPE II (CLEAR), RoHS COMPLIANT

ALL THREADS ARE GAUGED PRIOR TO PLATING

PART#1 EXAMPLE: 422D-480UMG
 4.80" LENGTH, M2 MOUNT HOLES, METRIC M2.5 SOCKET HEAD, GOLD CHEM FILM

PART#2 EXAMPLE: 422D-480UMG-CP
 SAME AS ABOVE PLUS CENTER MOUNTING HOLE AND LOCK PATCH OPTIONS

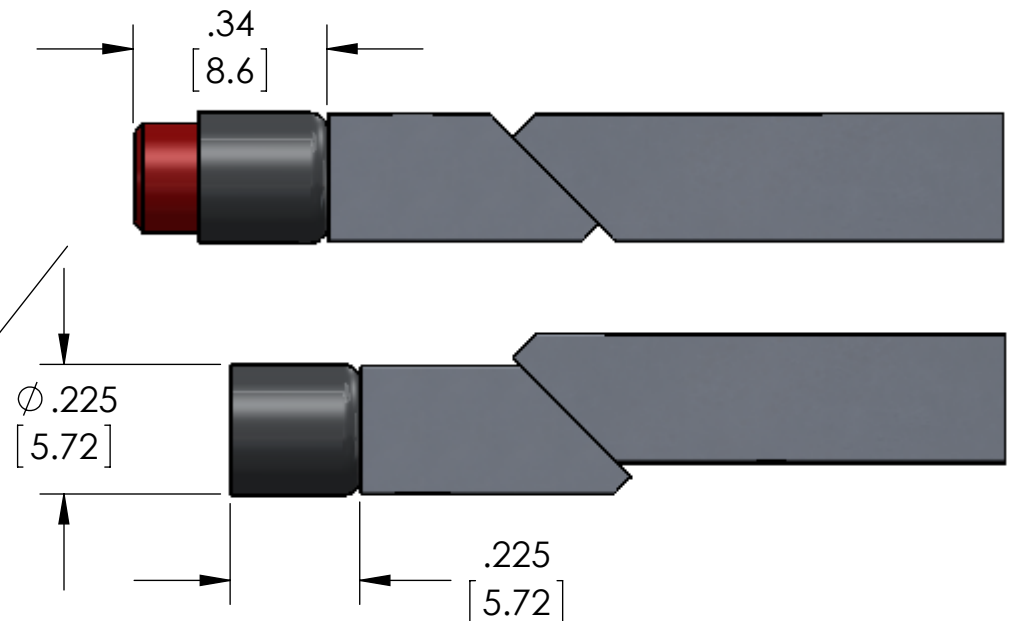
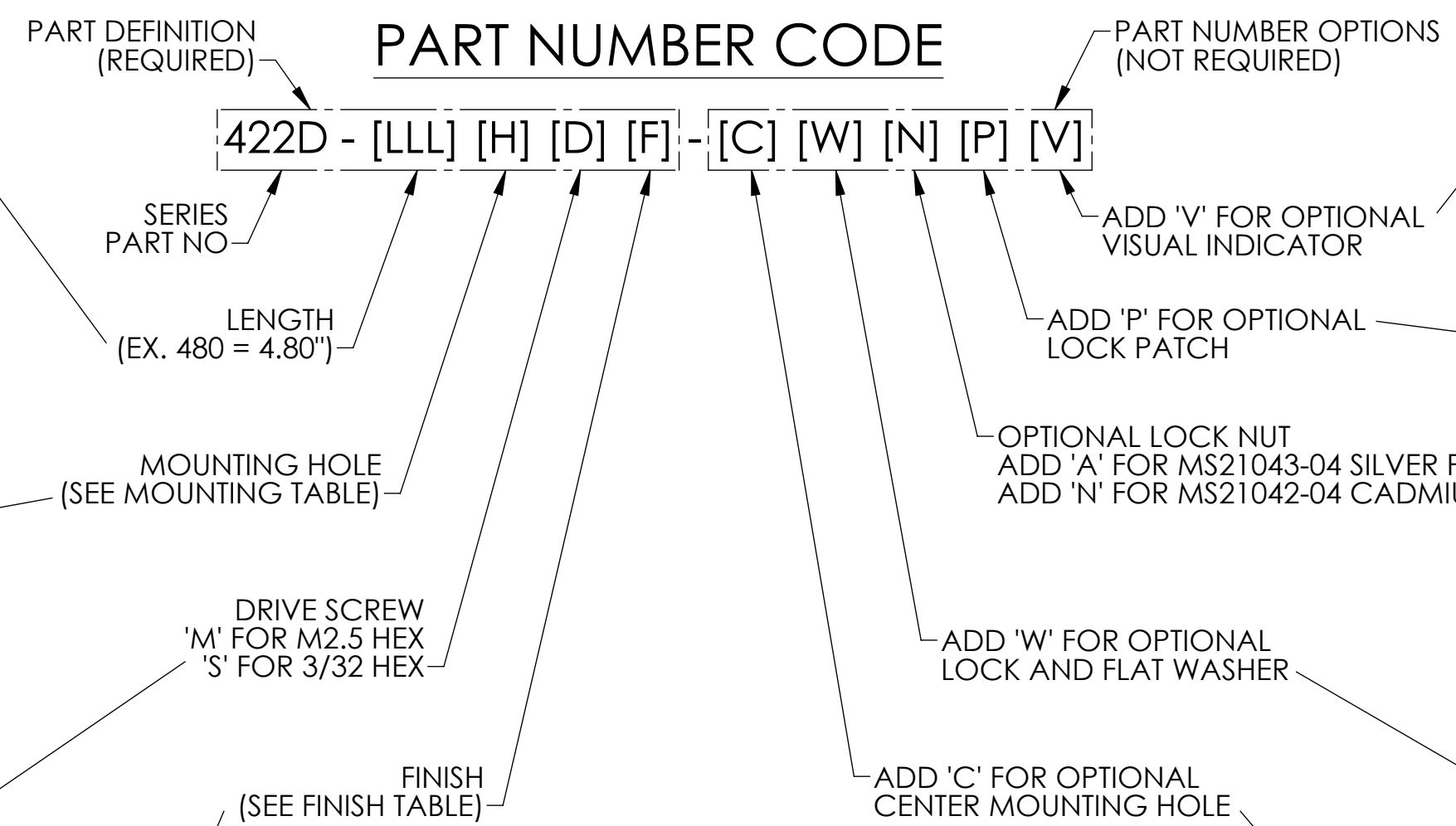

'V' OPTION
 VISUALLY CONFIRMS LOCKED IN PLACE WHEN RED SCREW HEAD IS CONCEALED

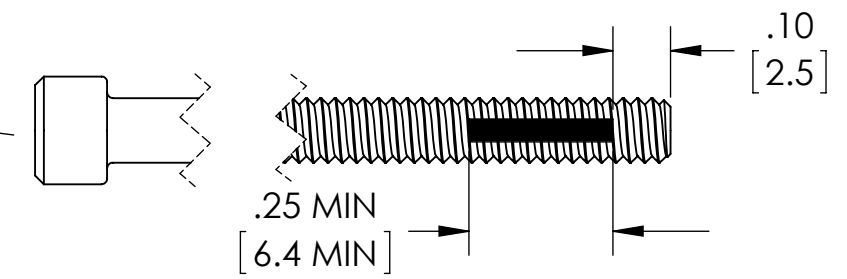

'P' OPTION
 NYLON PATCH PER MIL-F-18240 PROVIDES ADDITIONAL RESISTANCE TO SHOCK AND VIBRATION



'A' OR 'N' OPTION
 PREVENTS DISASSEMBLY OF REAR WEDGE FROM SCREW

'W' OPTION
 LOCK AND FLAT WASHERS

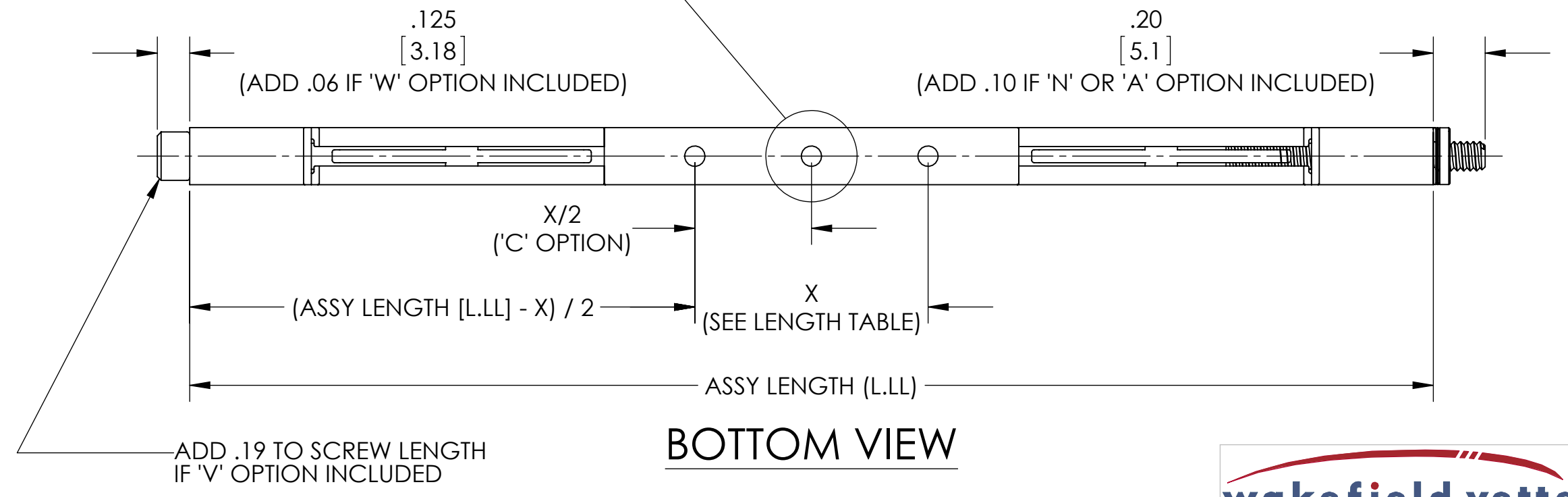

X-ON Electronics

Largest Supplier of Electrical and Electronic Components

Click to view similar products for [Heat Sinks](#) category:

Click to view products by [Wakefield](#) manufacturer:

Other Similar products are found below :

[581102B00000G](#) [656-15ABPE](#) [657-20ABPNE](#) [7020B-TC12-MTG](#) [73452PPBA](#) [7G0011A](#) [PF720G](#) [A22-4026](#) [HAH10L](#) [HAH15L](#) [HF20](#)
[1542616-1](#) [HS-2506-F1](#) [HS-87M0-F2](#) [218-40CTE3](#) [231-69PAB-15V](#) [25-7520](#) [SW50-4G](#) [231-75PAB-13V](#) [231-75PAB-15V](#) [253-122ABE-](#)
[22](#) [PSC22CB](#) [CLP212SG](#) [CLP-7701G](#) [HAA083](#) [HAF10L](#) [HAQ10T](#) [D10100-28](#) [TO5-002D](#) [BDN183CBA01](#) [3-21053-4](#) [32438](#) [TX0506-1B](#)
[TX1806B](#) [LAE66A3CB](#) [WA-DT2-101E](#) [511-3U](#) [73381PPBA](#) [73403PPBA](#) [7G0047C](#) [COMX-440-HSP](#) [510-12M](#) [D10650-40T5](#) [V8511](#) [Y](#)
[APF40-40-13CB/A01](#) [780653U04500G](#) [ATS-54310K-C2-R0](#) [FK 216 CB SA](#) [FK 231 SA 220](#) [648-51AB](#)