

# APPROVAL SHEET

**MR12, MR10, MR08, MR06, MR04**

**±1%, ±5%**

General purpose chip resistors

Size 1206, 1210, 0805, 0603, 0402  
( Automotive & Anti-Sulfuration )

\*Contents in this sheet are subject to change without prior notice.

## FEATURE

1. High reliability and stability  $\pm 1\%$
2. Sulfuration resistant
3. Automotive grade AEC Q-200 Compliant
4. 100% CCD inspection
5. RoHS compliant and Lead free products

## APPLICATION

- Automotive application
- Consumer electrical equipment
- EDP, Computer application
- Telecom application

## DESCRIPTION

The resistors are constructed in a high grade ceramic body (aluminum oxide). Internal metal electrodes are added at each end and connected by a resistive paste that is applied to the top surface of the substrate. The composition of the paste is adjusted to give the approximate resistance required and the value is trimmed to within tolerance by laser cutting of this resistive layer.

The resistive layer is covered with a protective coat. Finally, the two external end terminations are added. For ease of soldering the outer layer of these end terminations is a Tin (lead free) alloy.

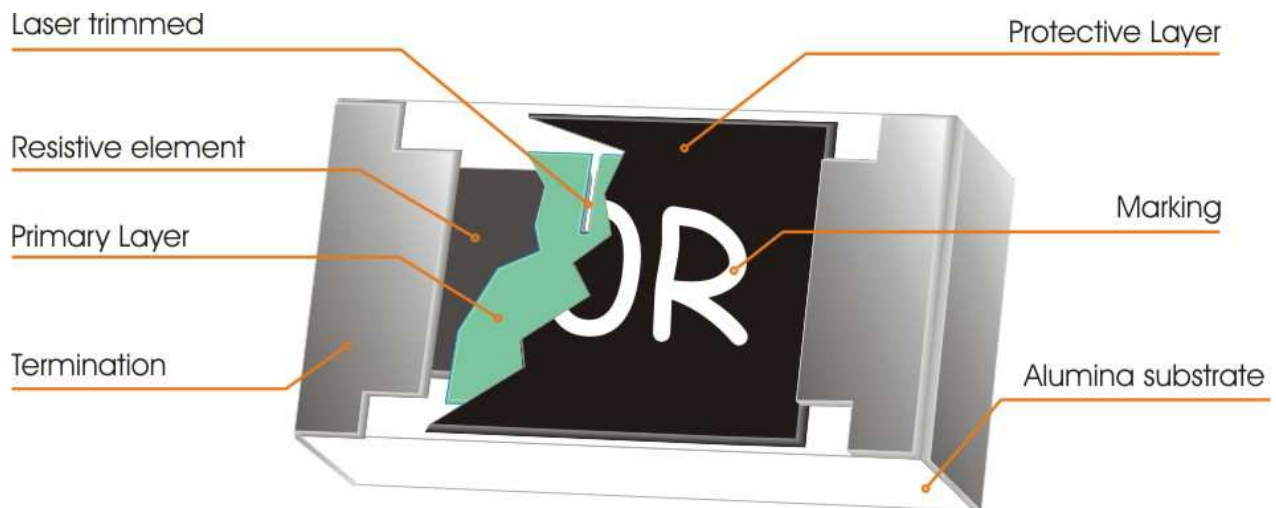

Fig 1. Construction of a Chip-R

**QUICK REFERENCE DATA**

Item	General Specification									
Series No.	MR10		MR12		MR08		MR06		MR04	
Size code	1210(3225)		1206(3216)		0805(2012)		0603(1608)		0402(1005)	
Resistance Range	1Ω~10MΩ (±5% tolerance), Jumper 1Ω~10MΩ (±1% tolerance)									
Resistance Tolerance	±1% E96/E24	±5% E24	±1% E96/E24	±5% E24	±1% E96/E24	±5% E24	±1% E96/E24	±5% E24	±1% E96/E24	±5% E24
TCR (ppm/°C)										
R > 1MΩ	≤ ± 200		≤ ± 200		≤ ± 200		≤ ± 200		≤ ± 200	
10Ω < R ≤ 1MΩ	≤ ± 100		≤ ± 100		≤ ± 100		≤ ± 100		≤ ± 100	
R ≤ 10Ω	-200~+400		-200~+400		-200~+400		-200~+400		-200~+400	
Max. dissipation @ T <sub>amb</sub> =70°C	1/2 W		1/4 W		1/8 W		1/10 W		1/16 W	
Max. Operation Voltage (DC or RMS)	200V		200V		150V		75V		50V	
Max. Overload Voltage (DC or RMS)	400V		400V		300V		150V		100V	
Climatic category (IEC 60068)	55/155/56									

Note :

- This is the maximum voltage that may be continuously supplied to the resistor element, see "IEC publication 60115-8"
- Max. Operation Voltage : So called RCWV (Rated Continuous Working Voltage) is determined by  

$$RCWV = \sqrt{\text{Rated Power} \times \text{Resistance Value}}$$
or Max. RCWV listed above, whichever is lower.
- The resistance of Jumper is defined <0.05Ω.

**DIMENSIONS (unit : mm)**

	MR10	MR12	MR08	MR06	MR04
<b>L</b>	3.10 ± 0.10	3.10 ± 0.10	2.00 ± 0.10	1.60 ± 0.10	1.00 ± 0.05
<b>W</b>	2.60 ± 0.10	1.60 ± 0.10	1.25 ± 0.10	0.80 ± 0.10	0.50 ± 0.05
<b>T</b>	0.55 ± 0.10	0.60 ± 0.15	0.50 ± 0.15	0.45 ± 0.15	0.35 ± 0.05
<b>Tb</b>	0.50 ± 0.20	0.45 ± 0.20	0.40 ± 0.20	0.30 ± 0.15	0.25 ± 0.10
<b>Tt</b>	0.50 ± 0.20	0.50 ± 0.20	0.40 ± 0.20	0.30 ± 0.10	0.20 ± 0.10

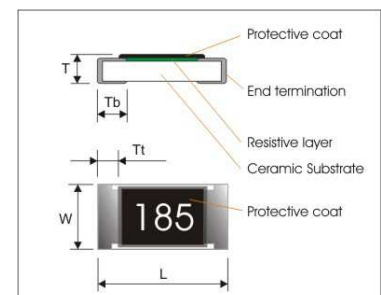

**MARKING**

Size \ Nr. Of digit of code\tolerance	$\pm 5\%$	$\pm 1\%$
<b>1210/1206/0805</b>	3-digits marking	4-digits marking
<b>0603 (1608)</b>	3-digits marking	3-digits marking
<b>0402(1005)</b>	NO MARKING	

**3-digits marking** ( $\pm 5\%$  : 1206, 1210, 0805 & 0603 )

Each resistor is marked with a three digits code on the protective coating to designate the nominal resistance value.

**3-digits marking** ( $\pm 1\%$  : 0603)

Nominal resistance	Description														
1.E-24 series	As 0603 WR06X $\pm 5\%$ .														
2.E-96 series	The 1st two digit codes are referring to the CODE on the table, the 3rd code is the index of resistance value : $Y=10^{-2}$ , $X=10^{-1}$ , $A=10^0$ , $B=10^1$ , $C=10^2$ , $D=10^3$ , $E=10^4$ , $F=10^5$ EX : 17.8 $\Omega$ =25X, 178 $\Omega$ =25A, 1K78 =25B 17K8=25C, 178K=25D, 1M78=25E														
3. Remark	There is no marking for the items are not under E-24 and E-96 series														
<b>CODE</b>	<b>R_value</b>	<b>CODE</b>	<b>R_value</b>	<b>CODE</b>	<b>R_value</b>	<b>CODE</b>	<b>R_value</b>	<b>CODE</b>	<b>R_value</b>	<b>CODE</b>	<b>R_value</b>	<b>CODE</b>	<b>R_value</b>	<b>CODE</b>	<b>R_value</b>
01	<b>100</b>	13	<b>133</b>	25	<b>178</b>	37	<b>237</b>	49	<b>316</b>	61	<b>422</b>	73	<b>562</b>	85	<b>750</b>
02	<b>102</b>	14	<b>137</b>	26	<b>182</b>	38	<b>243</b>	50	<b>324</b>	62	<b>432</b>	74	<b>576</b>	86	<b>768</b>
03	<b>105</b>	15	<b>140</b>	27	<b>187</b>	39	<b>249</b>	51	<b>332</b>	63	<b>442</b>	75	<b>590</b>	87	<b>787</b>
04	<b>107</b>	16	<b>143</b>	28	<b>191</b>	40	<b>255</b>	52	<b>340</b>	64	<b>453</b>	76	<b>604</b>	88	<b>806</b>
05	<b>110</b>	17	<b>147</b>	29	<b>196</b>	41	<b>261</b>	53	<b>348</b>	65	<b>464</b>	77	<b>619</b>	89	<b>825</b>
06	<b>113</b>	18	<b>150</b>	30	<b>200</b>	42	<b>267</b>	54	<b>357</b>	66	<b>475</b>	78	<b>634</b>	90	<b>845</b>
07	<b>115</b>	19	<b>154</b>	31	<b>205</b>	43	<b>274</b>	55	<b>365</b>	67	<b>487</b>	79	<b>649</b>	91	<b>866</b>
08	<b>118</b>	20	<b>158</b>	32	<b>210</b>	44	<b>280</b>	56	<b>374</b>	68	<b>499</b>	80	<b>665</b>	92	<b>887</b>
09	<b>121</b>	21	<b>162</b>	33	<b>215</b>	45	<b>287</b>	57	<b>383</b>	69	<b>511</b>	81	<b>681</b>	93	<b>909</b>
10	<b>124</b>	22	<b>165</b>	34	<b>221</b>	46	<b>294</b>	58	<b>392</b>	70	<b>523</b>	82	<b>698</b>	94	<b>931</b>
11	<b>127</b>	23	<b>169</b>	35	<b>226</b>	47	<b>301</b>	59	<b>402</b>	71	<b>536</b>	83	<b>715</b>	95	<b>953</b>
12	<b>130</b>	24	<b>174</b>	36	<b>232</b>	48	<b>309</b>	60	<b>412</b>	72	<b>549</b>	84	<b>732</b>	96	<b>976</b>

**4-digits marking** ( $\pm 1\%$  : 1210/1206/0805)

Each resistor is marked with a four digits code on the protective coating to designate the nominal resistance value.

**Example**

<b>RESISTANCE</b>	10 $\Omega$	12 $\Omega$	100 $\Omega$	6800 $\Omega$	47000 $\Omega$
<b>3-digits marking ( 1210, 1206, 0805, 0603 <math>\pm 5\%</math> )</b>	100	120	101	682	473
<b>4-digits marking</b>	10R0	12R0	1000	6801	4702

## FUNCTIONAL DESCRIPTION

### Product characterization

Standard values of nominal resistance are taken from the E24 series for resistors with a tolerance of  $\pm 5\%$ , and E24+E96 series for resistors with a tolerance of  $\pm 1\%$ . The values of the E24/E96 series are in accordance with "IEC publication 60063".

### Derating

The power that the resistor can dissipate depends on the operating temperature; see Fig.2.1

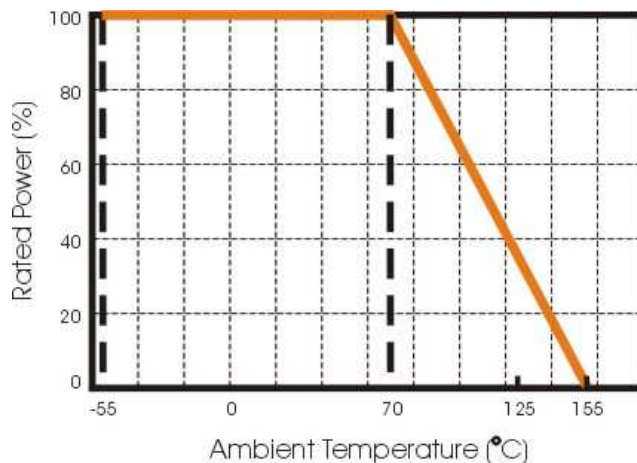

Figure 2.1 Maximum dissipation in percentage of rated power as a function of the ambient temperature

## MOUNTING

Due to their rectangular shapes and small tolerances, Surface Mountable Resistors are suitable for handling by automatic placement systems.

Chip placement can be on ceramic substrates and printed-circuit boards (PCBs).

Electrical connection to the circuit is by individual soldering condition.

The end terminations guarantee a reliable contact.

### SOLDERING CONDITION

The robust construction of chip resistors allows them to be completely immersed in a solder bath 260°C for 10 seconds. Therefore, it is possible to mount Surface Mount Resistors on one side of a PCB and other discrete components on the reverse (mixed PCBs).

Surface Mount Resistors are tested for solderability at 235°C during 2 seconds. The test condition for no leaching is 260°C for 30 seconds. Typical examples of soldering processes that provide reliable joints without any damage are given in Fig 3.

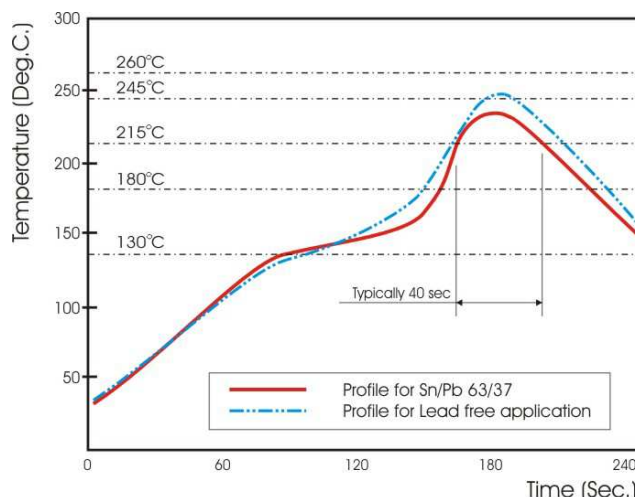

Fig 3. Infrared soldering profile for Chip Resistors

### CATALOGUE NUMBERS

The resistors have a catalogue number starting with .

MR12	X	472_	J	T	L
<b>Automotive code</b>	<b>Type code</b>	<b>Resistance code</b>	<b>Tolerance</b>	<b>Packaging code</b>	<b>Termination code</b>
MR10 : 1210	X :	±5%, E24: 2 significant digits followed by no. of zeros and a blank	F : ±1%	T : 7" Reeled taping	L = Sn base (lead free)
MR12 : 1206	±5%, 1Ω ~ 10MΩ	220Ω = 221_ ( " _ " means a blank )	J : ±5%	Q : 10" Reeled taping	
MR08 : 0805	W :	<b>Resistance code</b>	P : Jumper	G : 13" Reeled taping	
MR06 : 0603	±1%, < 10Ω; >1MΩ	±1%, E24+E96: 3 significant digits followed by no. of zeros		B : Bulk	
MR04: 0402		E96: 37.4KΩ = 3742			
		E24: 220Ω = 2200			

\* Anti-Sulfuration test conditions: H2S 3ppm, 40°C, RH 90%, 1000hrs, criteria: +/-1% !

MR10, MR12, MR08, MR06:

1. Reeled tape packaging : 8mm width paper taping 5000pcs per 7" reel, 10kpcs per 10" reel, 20kpcs per 13" reel.
2. Bulk packaging : 5000pcs per poly-bag

MR04:

1. Reeled tape packaging : 8mm width paper taping 10,000pcs per reel,
2. Bulk packaging : 10,000pcs per poly-bag

## TEST AND REQUIREMENTS

Essentially all tests are carried out according to the schedule of IEC publication 115-8, category **LCT/UCT/56**(rated temperature range : **Lower Category Temperature, Upper Category Temperature**; damp heat, long term, 56 days). The testing also meets the requirements specified by EIA, EIAJ and JIS.

The tests are carried out in accordance with IEC publication 68, "Recommended basic climatic and mechanical robustness testing procedure for electronic components" and under standard atmospheric conditions according to IEC 60068-1, sub-clause 5.3. Unless otherwise specified, the following value supplied :

Temperature: 15°C to 35°C.

Relative humidity: 45% to 75%.

Air pressure: 86kPa to 106 kPa (860 mbar to 1060 mbar).

All soldering tests are performed with mildly activated flux.

TEST	PROCEDURE / TEST METHOD	REQUIREMENTS	
		Resistance	0Ω
Electrical Characteristics <b>JISC5201-1: 1998</b> Clause 4.8	- DC resistance values measurement - Temperature Coefficient of Resistance (T.C.R) Natural resistance change per change in degree centigrade. $\frac{R_2 - R_1}{R_1(t_2 - t_1)} \times 10^6 \text{ (ppm/}^\circ\text{C)} \quad t_1 : 20^\circ\text{C}+5^\circ\text{C}-1^\circ\text{C}$ R <sub>1</sub> : Resistance at reference temperature R <sub>2</sub> : Resistance at test temperature	Within the specified tolerance Refer to "QUICK REFERENCE DATA"	
Resistance to soldering heat (R.S.H) <b>MIL-STD-202 method 210</b>	Un-mounted chips completely immersed for 10±1second in a SAC solder bath at 270°C±5°C	ΔR/R max. ±(0.5%+0.05Ω) No visible damage	<50mΩ
Solderability <b>J-STD-002</b>	a) Bake the sample for 155°C dwell time 4hrs/ solder dipping 235°C/ 5sec. b) Steam the sample dwell time 1 hour/ solder dipping 260°C/ 7sec.	95% coverage min., good tinning and no visible damage	
Temperature cycling <b>JESD22 method JA-104</b>	1000 cycles, -55°C ~ +155°C, dwell time 5~10min	ΔR/R max. ±(0.5%+0.05Ω) No visible damage	<50mΩ
Moisture Resistance <b>MIL-STD-202 method 106</b>	65±2°C, 80~100% RH, 10 cycles, 24 hours/ cycle	ΔR/R max. ±(0.5%+0.05Ω) No visible damage	<50mΩ
Bias Humidity <b>MIL-STD-202 method 103</b>	1000+48/-0 hours; 85°C, 85% RH, 10% of operation power	ΔR/R max. ±(1%+0.05Ω) No visible damage	<50mΩ
Operational Life <b>MIL-STD-202 method 108</b>	1000+48/-0 hours; 35% of operation power, 125±2°C	ΔR/R max. ±(1%+0.05Ω) No visible damage	<50mΩ

TEST	PROCEDURE / TEST METHOD	REQUIREMENTS	
		Resistance $\pm 5\%$ , $\pm 1\%$	0 $\Omega$
High Temperature Exposure <b>MIL-STD-202 method 108</b>	1000+48/-0 hours; without load in a temperature chamber controlled 155 $\pm$ 3 $^{\circ}$ C	$\Delta R/R$ max. $\pm(1\%+0.05\Omega)$ No visible damage	<50m $\Omega$
Mechanical Shock <b>MIL-STD-202 method 213</b>	1/2 Sine Pulse / 1500g Peak / Velocity 15.4ft/sec	Within the specified tolerance No visible damage	<50m $\Omega$
Board Flex <b>AEC-Q200-005</b>	Resistors mounted on a 90mm glass epoxy resin PCB(FR4), bending once 2mm for 10sec	$\Delta R/R$ max. $\pm(1.0\%+0.05\Omega)$ . No visible damage	<50m $\Omega$
Terminal strength <b>AEC-Q200-006</b>	Pressurizing force: 1Kg, Test time: 60 $\pm$ 1sec.	No remarkable damage or removal of the terminations	
Vibration <b>MIL-STD-202 method 204</b>	Test 5g's for 20min., 12 cycles each of 3 orientations	$\Delta R/R$ max. $\pm(1.0\%+0.05\Omega)$ No visible damage	<50m $\Omega$
Thermal shock <b>MIL-STD-202 method 107</b>	Test -55 to 155 $^{\circ}$ C / dwell time 15min/ Max transfer time 20sec 300cycles	$\Delta R/R$ max. $\pm(0.5\%+0.05\Omega)$ No visible damage	<50m $\Omega$
ESD <b>AEC-Q200-002</b>	Test contact 1.0KV ( 0.5KV for 0402 only)	$\Delta R/R$ max. $\pm(1\%+0.05\Omega)$ No visible damage	<50m $\Omega$

**TEST CONDITION FOR JUMPER (0  $\Omega$ )**

Item	MR10	MR12	MR08	MR06	MR04
Power Rating At 70 $^{\circ}$ C	1/2W	1/4W	1/8W	1/10W	1/16W
Resistance	MAX.50m $\Omega$				
Rated Current	3A	2A	1.5A	1A	1A
Peak Current	7.5A	5A	3.5A	3A	2A
Operating Temperature	-55 ~ +155 $^{\circ}$ C				



**PACKAGING**

Paper Tape specifications (unit :mm)

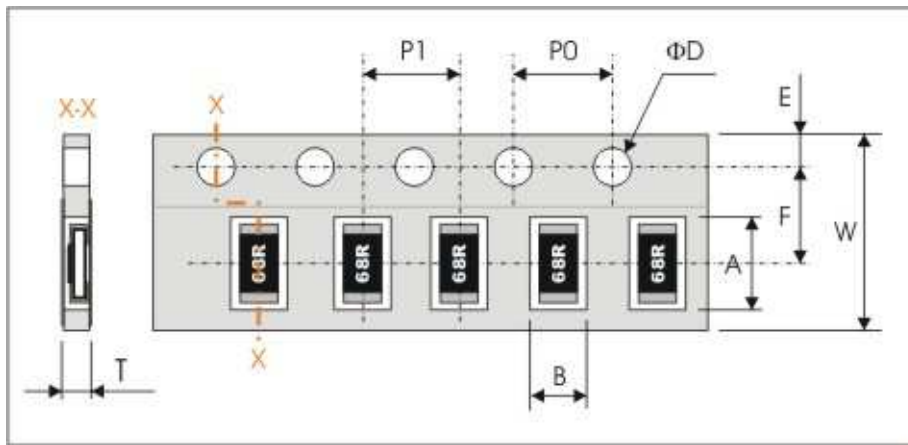

Series No.	A	B	W	F	E
MR10	3.60±0.20	3.00±0.20	8.00±0.30	3.50±0.20	1.75±0.10
MR12	3.60±0.20	2.00±0.20			
MR08	2.40±0.20	1.65±0.20			
MR06	1.90±0.20	1.10±0.20			
MR04	1.20±0.10	0.70±0.10			

Series No.	P1	P0	ΦD	T
MR10/12/08	4.00±0.10	4.00±0.10	Φ1.50 <sup>+0.1</sup> <sub>-0.0</sub>	Max. 1.0
MR06				0.65±0.05
MR04				0.40±0.05

**7" Reel dimensions**

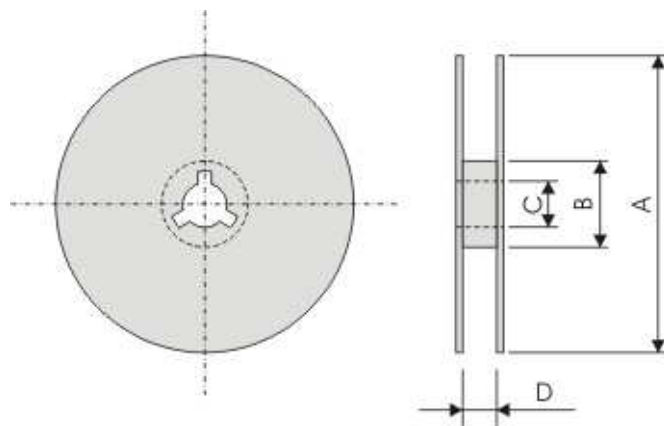

Symbol	A	B	C	D
(unit : mm)	Φ178.0±2.0	Φ60.0±1.0	13.0±0.2	9.0±0.5

## X-ON Electronics

Largest Supplier of Electrical and Electronic Components

*Click to view similar products for [Thick Film Resistors - SMD category](#):*

*Click to view products by [Walsin manufacturer](#):*

Other Similar products are found below :

[CRCW04028R20JNEE](#) [CRCW06036K80FKEE](#) [CRG1206F1K58](#) [CRL0603-FW-R700ELF](#) [M55342K06B6E19RWL](#) [RC1005F1072CS](#)  
[RC1005F471CS](#) [RC1005F4751CS](#) [RCP0603W100RGED](#) [RCWP72251K47FKWB](#) [RLR05C7501GPB14](#) [RLR07C5111FSBSL](#) [ERJ-](#)  
[1GMF1R00C](#) [ERJ-1GMF1R20C](#) [ERJ-1GMF2R55C](#) [ERJ-1GMF8R66C](#) [25121WF1003T4E](#) [25.501.3653.0](#) [290-1.0M-RC](#) [292-1.0M-RC](#) [292-](#)  
[2.2K-RC](#) [292-4.7K-RC](#) [25121WF4700T4E](#) [292-470K-RC](#) [302-1.0M-RC](#) [CPG1206F10KC](#) [CRCW02011R00FXED](#) [CRCW060315K0FKEE](#)  
[CRCW060320K5FKEE](#) [CRG0201F10K](#) [RCG0402150RFKED](#) [RCG04023K92FKED](#) [RCP2512B100RGWB](#) [RCWP110010R0FKS3](#)  
[RCWP11002K00FKS3](#) [RCWP12061K00FKS2](#) [3520510RJT](#) [352075KJT](#) [M55342K11B9E53RUL](#) [RMC16-102JT](#) [RMC1JPTE](#) [TR0603MR-](#)  
[075K1L](#) [5-2176094-4](#) [35202K7JT](#) [WF06Q1000FTL](#) [ERJ-S03J1R0V](#) [ERJ-S14J4R7U](#) [CHP2512L4R30GNT](#) [CPCC10270R0JE32](#)  
[WR12X1621FTL](#)