

Preliminary Product Information

DP4T Switch

- **RFASWCM0624ATF09**
- **For 0.7~2.7GHz Band Working Frequency**

FEATURES

- Low Insertion Loss : 0.4dB typ. @ 2.7GHz
- High Isolation : 26dB typ. @ 2.7GHz
- Low control voltage : 1.2 to 2.0 V
- Miniature footprint : 1.1 x 1.5 x 0.47 mm³

Description

- The RFASWCM0624ATF09 is a SOI (Silicon On Insulator) Single-Pole, Double-Throw (SPDT) differential switch operating at 0.7-2.7 GHz in a QFN-10 (1.1x1.5x0.47mm³) package.
- The RFASWCM0624ATF09 features very high isolation with very low DC power consumption.
- The RFASWCM0624ATF09 has ESD protection devices to achieve excellent ESD performances. No DC Blocking capacitors are required for all RF ports unless DC is biased externally.

Application

- Multi-mode 2G/3G, LTE application transmit/receive system.

Block Diagram and Pin Out (Top View)

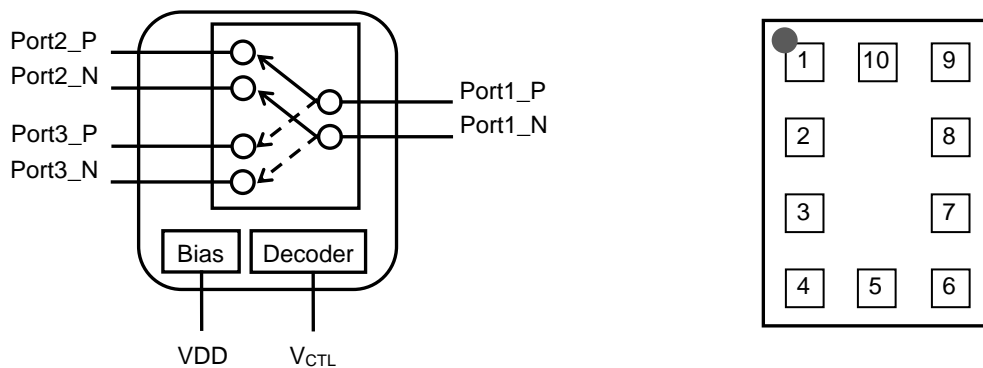

Pin Names and Descriptions

Pin	Name	Description	Pin	Name	Description
1	RF3_P	Differential Output P of Port 3	6	V _{CTL}	DC control voltage
2	GND	Ground	7	RF1_P	Differential Input P of Port 1
3	GND	Ground	8	RF1_N	Differential Input N of Port 1
4	RF2_N	Differential Output N of Port 2	9	VDD	DC power supply
5	RF2_P	Differential Output P of Port 2	10	RF3_N	Differential Output N of Port 3

Preliminary Product Information

Application Circuit

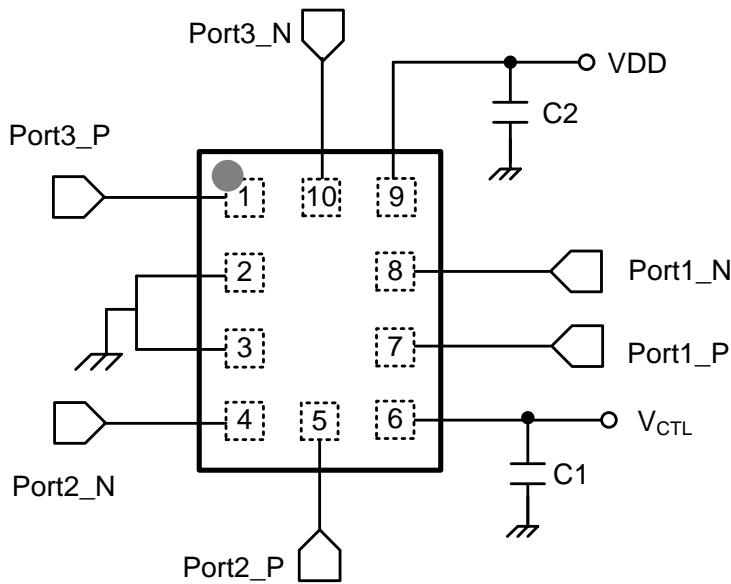

Note: No DC Blocking capacitors are required for all RF ports unless DC is biased externally.

Parts List

Parts No.	Value
C1	33 pF
C2	1 μ F

Absolute Maximum Ratings

Parameter	Symbol	Minimum	Maximum	Units
RFx Input Power	P _{in}		+35	dBm
DC Supply Voltage	V _{DD}	+2.4	+4.0	V
DC Control Voltage	V _{CTL}		+2.5	V
Storage temperature	T _{STG}	-65	+160	°C
Operating temperature	T _{OP}	-35	+90	°C

Exceeding absolute maximum ratings may cause permanent damage. Operation between operating range maximum and absolute maximum for extended periods may reduce reliability.

Preliminary Product Information

Electrical Specifications at 25°C with VDD=2.8V, V_{CTL}=0/1.8V, Characteristic Impedance Z₀=50Ω, Pin=0dBm

Parameter	Symbol	Test Condition	Min.	Typ.	Max.	Units
UMTS band						
Insertion loss						
Port2_P - Port1_P Port2_N - Port1_N Port3_P - Port1_P Port3_N - Port1_N	IL	824MHz ~ 960MHz	-	0.25	0.40	dB
		1710MHz ~ 2170MHz	-	0.35	0.50	dB
Isolation						
Port3_P/N - Port1_P/N Port3_P/N - Port2_P/N	Iso	824MHz to 960MHz ; Port2 to Port1 active	28 38	35 42		dB dB
Port2_P/N - Port1_P/N Port2_P/N - Port3_P/N		824MHz to 960MHz ; Port3 to Port1 active	28 38	35 42		dB dB
Port3_P/N - Port1_P/N Port3_P/N - Port2_P/N		1710MHz to 2170MHz ; Port2 to Port1 active	23 30	25 32		dB dB
Port2_P/N - Port1_P/N Port2_P/N - Port3_P/N		1710MHz to 2170MHz ; Port3 to Port1 active	23 30	25 32		dB dB
Harmonics						
Port2 or 3 to Port1 (2fo)	2fo, 3fo, 4fo	CW, Pin = 20dBm, 50Ω TX = 824MHz to 960MHz; TX = 1710MHz to 2170MHz;		90 90	85 85	dBc dBc
Port2 or 3 to Port1 (3fo)		CW, Pin = 20dBm, 50Ω TX = 824MHz to 960MHz; TX = 1710MHz to 2170MHz;		90 90	85 85	dBc dBc
Port2 or 3 to Port1 (4fo to 12.75GHz)		CW, Pin = 20dBm, 50Ω TX = 824MHz to 960MHz; TX = 1710MHz to 2170MHz;		85 85	83 83	dBc dBc
Phase Balance						
		Between active paths; Test frequency 960MHz; Test frequency 2170MHz;	-3 -3	0 0	3 3	Deg. Deg.
Amplitude Balance						
		Between active paths; Test frequency 960MHz; Test frequency 2170MHz;	-1 -1	0 0	1 1	dB dB
VSWR						
	VSWR	824MHz to 960MHz; 1710MHz to 2170MHz;			1.5 1.5	-
DC Specification (Decoder)						
Supply Voltage	VDD		2.4	2.8	3.3	V
Supply Current	IDD	VDD= 2.8V	-	120	155	μA
Control Voltage(High)	V _{CTL(H)}		1.2	1.8	2.0	V
Control Voltage(Low)	V _{CTL(L)}		0		0.45	V
Control Current	I _{CTL}	V _{CTL} = 1.8V	-	0.5	1.0	μA
Switching Specification						
Switching speed	T _{SW}	50% V _{CTL} to 90/10% RF	-	2	5	μs

Note: All measurements made in a 50 ohm system with 0/+1.8V control voltages, unless otherwise specified.

Preliminary Product Information

Electrical Specifications at 25°C with VDD=2.8V, V_{CTL}=0/1.8V, Characteristic Impedance Z₀=50Ω, Pin=0dBm

Parameter	Symbol	Test Condition	Min.	Typ.	Max.	Units
LTE band						
Insertion loss						
Port2_P - Port1_P Port2_N - Port1_N Port3_P - Port1_P Port3_N - Port1_N	IL	698MHz to 792MHz		0.25	0.40	dB
		2300MHz to 2690MHz		0.40	0.55	dB
Isolation						
Port3_P/N - Port1_P/N Port3_P/N - Port2_P/N	Iso	698MHz to 792MHz Port2 to Port1 active	28 38	38 42		dB dB
Port2_P/N - Port1_P/N Port2_P/N - Port3_P/N		698MHz to 792MHz Port3 to Port1 active	28 38	38 42		dB dB
Port3_P/N - Port1_P/N Port3_P/N - Port2_P/N		2300MHz to 2690MHz Port2 to Port1 active	20 24	28 26		dB dB
Port2_P/N - Port1_P/N Port2_P/N - Port3_P/N		2300MHz to 2690MHz Port3 to Port1 active	20 24	28 26		dB dB
Harmonics						
Port2 or 3 to Port1 (2fo)	2fo, 3fo, 4fo	CW, Pin = 20dBm, 50Ω TX = 698MHz to 792MHz; TX = 2300MHz to 2690MHz;		90 90	85 85	dBc dBc
Port2 or 3 to Port1 (3fo)		CW, Pin = 20dBm, 50Ω TX = 698MHz to 792MHz; TX = 2300MHz to 2690MHz;		90 90	85 85	dBc dBc
Port2 or 3 to Port1 (4fo to 12.75GHz)		CW, Pin = 20dBm, 50Ω TX = 698MHz to 792MHz; TX = 2300MHz to 2690MHz;		85 85	83 83	dBc dBc
Phase Balance						
		Between active paths; Test frequency 792MHz; Test frequency 2690MHz;	-3 -4	0 0	3 4	Deg. Deg.
Amplitude Balance						
		Between active paths; Test frequency 792MHz; Test frequency 2690MHz;	-1 -1	0 0	1 1	dB dB
VSWR						
	VSWR	698MHz to 792MHz; 2300MHz to 2690MHz;			1.5 1.5	-
DC Specification (Decoder)						
Supply Voltage	VDD		2.4	2.8	3.3	V
Supply Current	IDD	VDD= 2.8V	-	120	155	μA
Control Voltage(High)	V _{CTL(H)}		1.2	1.8	2.0	V
Control Voltage(Low)	V _{CTL(L)}		0		0.45	V
Control Current	I _{CTL}	V _{CTL} = 1.8V	-	0.5	1.0	μA
Switching Specification						
Switching speed	T _{SW}	50% V _{CTL} to 90/10% RF	-	2	5	μs

Note: All measurements made in a 50 ohm system with 0/+1.8V control voltages, unless otherwise specified.

Preliminary Product Information

Logic Table for Switch On-Path (High=1.8V ,Low= 0V)

V _{CTL}	Insertion Loss Path
0	Port1 to Port2 active
1	Port1 to Port3 active

Package Dimensions

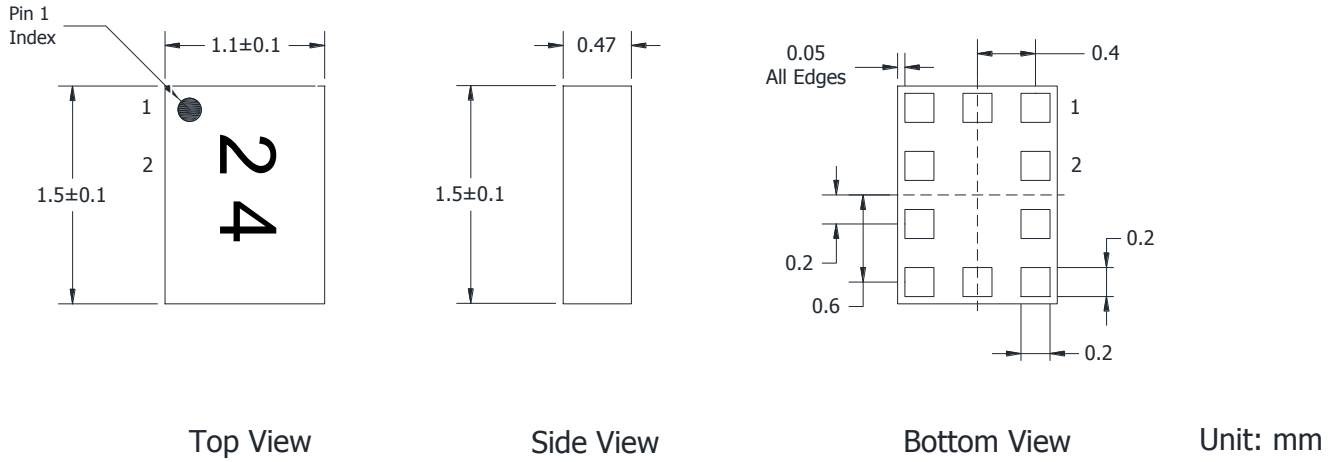

Solder Land Pattern

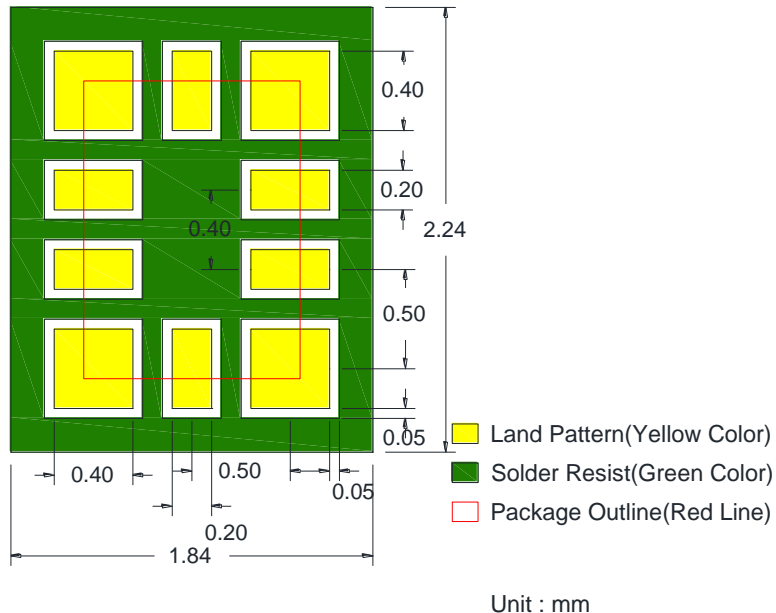

Line width is designed to match 50 Ω characteristic impedance, depending on PCB material and thickness

CONTACT INFORMATION

For more information, please contact with

Walsin Technology Corporation.

Tel : 886-3-475-8711

Fax : 886-3-475-5197

E mail : info@passivecomponent.com

Web Site : http://www.passivecomponent.com

Specification subject to change without prior notice.

X-ON Electronics

Largest Supplier of Electrical and Electronic Components

Click to view similar products for [RF Switch ICs](#) category:

Click to view products by [Walsin](#) manufacturer:

Other Similar products are found below :

[MASW-004100-11930W](#) [MASW-008853-TR3000](#) [MASW6010G](#) [BGSX210MA18E6327XTSA1](#) [CG2185X2](#) [CG2415M6](#) [MA4AGSW1A](#)
[MA4SW410](#) [MA4SW410B-1](#) [MASW-002102-13580G](#) [MASW-005100-11940W](#) [BGS 12PL6 E6327](#) [BGS1414MN20E6327XTSA1](#)
[BGS1515MN20E6327XTSA1](#) [SKY13374-397LF](#) [CG2415M6-C2](#) [AS222-92LF](#) [MASWSS0201TR](#) [MASW-007075-000100](#) [MASW-004103-13655P](#) [MASW-003102-13590G](#) [MASWSS0202TR-3000](#) [MASW-008543-TR3000](#) [MA4SW310B-1](#) [SW-313-PIN](#) [CG2430X1](#) [SKY13405-490LF](#) [SKYA21001](#) [SKY13415-485LF](#) [MMS008PP3](#) [SKY13319-374LF](#) [SKY13404-466LF](#) [SKY13473-569LF](#) [SKY13626-685LF](#)
[NJG1809ME7-TE1](#) [SKY13343-92LF](#) [MASW-002103-13635P](#) [SKY13417-485LF](#) [MASW-004103-13650P](#) [NJG1649HB6](#)
[RFASWE660DTF03](#) [BGSA14GN10E6327](#) [FM1694C](#) [XMSS1R6G0PA-001](#) [AW13612FLR](#) [AW13102DNR](#) [FM3418C](#) [AW13508QNR](#)
[AW13418RQNR](#) [FM8648M](#)