

PRODUCT SPECIFICATION

PRODUCT: CERAMIC DISC CAPACITOR

**TYPE: 50V, 100V, 500V, 1KV, 2KV, TEMPERATURE
COMPENSATING CAPACITOR**

CUSTOMER: _____

DOC. NO.: POE-D01-00-E-16

Ver.: 16

APPROVED BY CUSTOMER

VENDOR :

WALSIN TECHNOLOGY CORPORATION

566-1, KAO SHI ROAD, YANG-MEI
TAO-YUAN, TAIWAN

PAN OVERSEAS (GUANGZHOU) ELECTRONIC CO.,LTD.

NO.277,HONG MING ROAD,EASTERN SECTION,
GUANG ZHOU ECONOMIC AND TECHNOLOGY
DEVELOPMENT ZONE,CHINA

MAKER : PAN OVERSEAS (GUANGZHOU) ELECTRONIC CO.,LTD.

NO.277,HONG MING ROAD,EASTERN SECTION,
GUANG ZHOU ECONOMIC AND TECHNOLOGY
DEVELOPMENT ZONE,CHINA



50V, 100V, 500V, 1KV, 2KV TEMPERATURE COMPENSATING CERAMIC DISC CAPACITOR	POE-D01-00-E-16	Ver: 16 Page: 2 of 19
---	-----------------	--------------------------

Record of change

Date	Version	Description	page																																																												
2008.6.3	1	1. D08-00-E-14 (before) → POE-D01-00-E-01 (1 st edition)																																																													
2008.8.22	2	1. Revised diameter as below : <table border="1" style="width: 100%; border-collapse: collapse; margin-top: 10px;"> <thead> <tr> <th style="width: 25%;">Before</th> <th style="width: 25%;">Now</th> <th style="width: 25%;">Before</th> <th style="width: 25%;">Now</th> </tr> </thead> <tbody> <tr><td>CH5000R5X040*</td><td>not available</td><td>SL500181X060*</td><td>SL500181X050*</td></tr> <tr><td>CH1010R5X040*</td><td>not available</td><td>SL500241X070*</td><td>SL500241X060*</td></tr> <tr><td>CH501360X050*</td><td>CH501360X060*</td><td>SL500361X080*</td><td>SL500361X070*</td></tr> <tr><td>CH501620X080*</td><td>CH501620X060*</td><td>SL500391X080*</td><td>SL500391X070*</td></tr> <tr><td>CH501680X080*</td><td>CH501680X060*</td><td>SL101181X060*</td><td>SL101181X050*</td></tr> <tr><td>CH501750X080*</td><td>CH501750X060*</td><td>SL101241X070*</td><td>SL101241X060*</td></tr> <tr><td>CH501820X080*</td><td>CH501820X070*</td><td>SL101361X080*</td><td>SL101361X070*</td></tr> <tr><td>CH501101X080*</td><td>CH501101X070*</td><td>SL101391X080*</td><td>SL101391X070*</td></tr> <tr><td>CH102080X060*</td><td>CH102080X050*</td><td>SL102680X060*</td><td>SL102680X050*</td></tr> <tr><td>CH102100X060*</td><td>CH102100X050*</td><td>SL102121X100*</td><td>SL102121X060*</td></tr> <tr><td>CH102120X060*</td><td>CH102120X050*</td><td>SL102151X100*</td><td>SL102151X070*</td></tr> <tr><td>CH102620X080*</td><td>CH102620X070*</td><td>SL102181X100*</td><td>SL102181X070*</td></tr> <tr><td>CH102820X100*</td><td>CH102820X080*</td><td>SL102201X100*</td><td>SL102201X080*</td></tr> <tr><td></td><td></td><td>SL102221X100*</td><td>SL102221X080*</td></tr> </tbody> </table> 2. Complete lead code. 3. Add last SAP code " H" for halogen and Pb free , epoxy resin..	Before	Now	Before	Now	CH5000R5X040*	not available	SL500181X060*	SL500181X050*	CH1010R5X040*	not available	SL500241X070*	SL500241X060*	CH501360X050*	CH501360X060*	SL500361X080*	SL500361X070*	CH501620X080*	CH501620X060*	SL500391X080*	SL500391X070*	CH501680X080*	CH501680X060*	SL101181X060*	SL101181X050*	CH501750X080*	CH501750X060*	SL101241X070*	SL101241X060*	CH501820X080*	CH501820X070*	SL101361X080*	SL101361X070*	CH501101X080*	CH501101X070*	SL101391X080*	SL101391X070*	CH102080X060*	CH102080X050*	SL102680X060*	SL102680X050*	CH102100X060*	CH102100X050*	SL102121X100*	SL102121X060*	CH102120X060*	CH102120X050*	SL102151X100*	SL102151X070*	CH102620X080*	CH102620X070*	SL102181X100*	SL102181X070*	CH102820X100*	CH102820X080*	SL102201X100*	SL102201X080*			SL102221X100*	SL102221X080*	8-9 6-7 5
Before	Now	Before	Now																																																												
CH5000R5X040*	not available	SL500181X060*	SL500181X050*																																																												
CH1010R5X040*	not available	SL500241X070*	SL500241X060*																																																												
CH501360X050*	CH501360X060*	SL500361X080*	SL500361X070*																																																												
CH501620X080*	CH501620X060*	SL500391X080*	SL500391X070*																																																												
CH501680X080*	CH501680X060*	SL101181X060*	SL101181X050*																																																												
CH501750X080*	CH501750X060*	SL101241X070*	SL101241X060*																																																												
CH501820X080*	CH501820X070*	SL101361X080*	SL101361X070*																																																												
CH501101X080*	CH501101X070*	SL101391X080*	SL101391X070*																																																												
CH102080X060*	CH102080X050*	SL102680X060*	SL102680X050*																																																												
CH102100X060*	CH102100X050*	SL102121X100*	SL102121X060*																																																												
CH102120X060*	CH102120X050*	SL102151X100*	SL102151X070*																																																												
CH102620X080*	CH102620X070*	SL102181X100*	SL102181X070*																																																												
CH102820X100*	CH102820X080*	SL102201X100*	SL102201X080*																																																												
		SL102221X100*	SL102221X080*																																																												
2008.12.12	3	1. Complete the 13 th to 17 th codes of SAP P/N. 2. Page layout adjustment. 3. Added Marking when the coating resin is Halogen and PB free Epoxy.	5-9																																																												
2009.8.19	4	1 Change PSA & POE logo to Walsin & POE logo. 2. Operating temperature range change from -25℃ ~ +85℃ to -25℃ ~ +125℃, and the loading temperature of High Temperature Loading change from +85℃ to +125℃ (but the T.C.C temperature didn't change).	13 15																																																												
2010.8.24	5	1. Change the diameter dimension from 060 to 070 for P/N CH 500V 62pF&68pF&75pF. 2. Add 10pF~39pF(Code of diameter dimension is 050) for P/N SL 1KV.	8 9																																																												
2012/5/10	6	1). Review the size Dφ of the item CH/500V/121&151 from "100" to be "080"; 2). Review the size Dφ for the item CH/1000V/820 from "080" to be "070", CH/1000V/101 from "100" to be "070".	8 8																																																												
2012/12/5	7	Add 8.6. Ambient Temp of Allowable Voltage Graph (500Vdc to 2kVdc)	18-19																																																												
2013/5/6	8	1. Review the Lead diameter φ from 0.60 +/-0.06mm to 0.55+/-0.05mm 2. Review the "DΦ≤6.0mm shall be omitted." to " DΦ≤060 shall be omitted." 3. Review the Solderability temperature from 255(+5/-0)℃ to 245±5℃ , Solderability time from 2 ±0.5s to 5±0.5s.	7,10 9 13																																																												
2013/10/18	9	Review the packing specification	11																																																												
2015/8/31	10	Modify the contents of the use of epoxy resin for 1KV products	8-9																																																												
2015/9/23	11	1. Modify the contents of the temperature characteristic. 2. Delete the definition about "Old Part No." 3. Delete 300 Pf~391 pF (Code of diameter dimension is 110&120) for P/N CH 50V&100V. 4. Delete 82 pF &100 pF (Code of diameter dimension is 070) and 120 pF &150 pF (Code of diameter dimension is 080) for P/N CH 500V. 5. Delete 56 pF &68pF~100pF (Code of diameter dimension is 070) for P/N CH 1KV. 6. Delete 4pF~22pF (Code of diameter dimension is 060) and 24pF~47pF (Code of diameter dimension is 070) for P/N CH 2KV.	5, 6,7 8 8 8 8																																																												
2016/3/2	12	1. Review the Available lead code of Lead Configuration. 2. Review 8.6. Ambient Temp of Allowable Voltage Graph (500Vdc to 2kVdc) 3. Review 9. Drawing of internal structure and material list	6-7 17-18 19																																																												

50V, 100V, 500V, 1KV, 2KV TEMPERATURE COMPENSATING CERAMIC DISC CAPACITOR	POE-D01-00-E-16	Ver: 16 Page: 3 of 19
---	-----------------	--------------------------

Date	Version	Description	page	
2016/5/3	13	1. Revised diameter as below :	9	
		Before		Now
		SL202181J100*		SL202181J080*
		SL202201J100*		SL202201J080*
		SL202221J100*		SL202221J080*
		SL202241J100*		SL202241J080*
		SL202271J100*		SL202271J080*
		SL202301J120*		SL202301J110*
SL202331J120*	SL202331J110*			
2016/11/3	14	1. Delete "CH" series.	5,8,12~13	
2016/12/21	15	1. Revised the product diameter for SL 50V~500V	8	
2017/9/27	16	1. Delete 8pF~12pF (Code of diameter dimension is 040) for P/N SL 50V&100V.	8	
		2. Delete 8pF~15pF (Code of diameter dimension is 050) for P/N SL 500V.		
		3. Delete 10pF~12pF (Code of diameter dimension is 050) for P/N SL 1KV.		



50V, 100V, 500V, 1KV, 2KV TEMPERATURE COMPENSATING CERAMIC DISC CAPACITOR	POE-D01-00-E-16	Ver: 16 Page: 4 of 19
---	-----------------	--------------------------

Table of Contents

No.	Item	Page
1	Part number for SAP system	5/19
2	Mechanical	6/19~7/19
3	Capacitance value vs. Rate voltage, product diameter	8/19
4	Marking	8/19
5	Taping Format	9/19
6	Packing specification	10/19
7	Specification and test method	11/19~14/19
8	Cautions & notices	15/19~18/19
9	Drawing of internal structure and material list	19/19



50V, 100V, 500V, 1KV, 2KV TEMPERATURE COMPENSATING CERAMIC DISC CAPACITOR	POE-D01-00-E-16	Ver: 16 Page: 5 of 19
---	-----------------	--------------------------

1. Part number for SAP system(total eighteen code) :

SL 102 470 J 050 B 20 C 5 H
 ① ② ③ ④ ⑤ ⑥ ⑦ ⑧ ⑨ ⑩

① Temperature characteristic :

SL: +350~-1000ppm/°C

② Rated voltage (Vdc) :

Voltage	50V	100V	500V	1000V	2000V
Code	500	101	501	102	202

③ Capacitance(pF) :

Capacitors (pF)	47	100	330	470	820
Code	470	101	331	471	821

④ Capacitance tolerance : D: ±0.5pF (For6~10pF) 、J: ±5% (For above 10pF)

⑤ Nominal body diameter dimension :

Diameter size	4mm	5mm	6mm	7mm	8mm	9mm	10mm	11mm	12mm
Code	040	050	060	070	080	090	100	110	120

⑥ Code of lead type : Please refer to Item “2.Mechanical”.

⑦ Packing mode and lead’s length (identified by 2-figure code)

Taping Code	Description
AN	Ammo / Pitch of component:12.7 mm

Bulk Code	Description
3E	Lead’s length L : 3.5mm
04	Lead’s length L : 4mm
4E	Lead’s length L : 4.5mm
20	Lead’s length L : 20mm

⑧ Length tolerance

Code	Description
A	±0.5 mm(Only for short kink lead code)
B	±1.0 mm
C	Min.
D	Taping special purpose

⑨ Pitch

Code	Description	Code	Description
5	5.0±0.8mm (For Bulk)	7	7.5 ±1mm
5	5.0+0.8mm-0.2mm (For Taping)	0	10.0 ±1mm
2	2.5 ±0.8 mm		

⑩ Coating code

Code	Description
P	Phenolic resin -Pb free
A	Halogen free and Pb free, phenolic resin
B	Epoxy Resin , Pb free
H	Halogen free and Pb free , epoxy resin

50V, 100V, 500V, 1KV, 2KV TEMPERATURE COMPENSATING CERAMIC DISC CAPACITOR	POE-D01-00-E-16	Ver: 16 Page: 6 of 19
---	-----------------	--------------------------

2. Mechanical:

Available lead code: (unit: mm)

Lead type	SAP P/N (13-17) digits	Pitch (F)	Lead length (L)	Available rated voltage	Packing	Lead configuration	
Lead style : B Straight long lead	B20C2	2.5 ± 0.8	20 MIN.	50V&100V, 500V, 1KV,2KV	Bulk		
	B20C5	5.0 ± 0.8	20 MIN.				
	B20C6	6.4 ± 1.0	20 MIN.				
	B20C0	10 ± 1.0	20 MIN.		Tap. Ammo		
	B20C7	7.5 ± 1.0	20 MIN.				
	BAND5	5.0 ^{+0.8} _{-0.2}	Taping Spec. (Ref. to page.10)				
BAND2	2.5 ± 0.8	50V&100V					
Lead style : L Straight short lead	L05B2	2.5 ± 0.8	5.0 ± 1.0	50V&100V, 500V, 1KV, 2KV	Bulk		
	L05B5	5.0 ± 0.8	5.0 ± 1.0				
	L05B0	10 ± 1.0	5.0 ± 1.0				
	L05B6	6.4 ± 1.0	5.0 ± 1.0				
	L05B7	7.5 ± 1.0	5.0 ± 1.0				
	L4EB5	5.0 ± 0.8	4.5 ± 1.0				
	L4EB7	7.5 ± 1.0	4.5 ± 1.0				
L4EB0	10 ± 1.0	4.5 ± 1.0					
Lead style : H Inside kink lead	H3EA5	5.0 ± 0.8	3.5 ± 0.5	50V&100V, 500V, 1KV	Bulk		
	H04A5	5.0 ± 0.8	4.0 ± 0.5				
	H4EB5	5.0 ± 0.8	4.5 ± 1.0				
	H05B5	5.0 ± 0.8	5.0 ± 1.0				
	H20C5	5.0 ± 0.8	20 MIN.				
	HAND5	5.0 ^{+0.8} _{-0.2}	Taping SPEC. (Ref. to page.10)				
	H05B7	7.5 ± 1.0			5.0 ± 1.0		
	H05B0	10 ± 1.0	5.0 ± 1.0		50V&100V, 500V, 1KV,2KV		Bulk
	H20C0	10 ± 1.0	20 MIN.				
	H04A7	7.5 ± 1.0	4.0 ± 0.5				
	H04A0	10 ± 1.0	4.0 ± 0.5				
	H3EA7	7.5 ± 1.0	3.5 ± 0.5				
	H3EA0	10 ± 1.0	3.5 ± 0.5				
	H4EB7	7.5 ± 1.0	4.5 ± 1.0				
H4EB0	10 ± 1.0	4.5 ± 1.0					
Lead style : X Outside kink lead	X3EA5	5.0±0.8	3.5 ± 0.5	50V&100V, 500V, 1KV, 2KV	Bulk		
	X3EA7	7.5±1.0					
	X3EA0	10±1.0					
	X04A5	5.0±0.8	4.0 ± 0.5				
	X04A7	7.5±1.0					
	X04A0	10±1.0					
	X05B5	5.0±0.8	5.0 ± 1.0				
	X05B7	7.5±1.0					
X05B0	10±1.0						
Lead style : D Vertical kink short lead	D04A5	5.0±1.0	4.0 ± 0.5	50V&100V, 500V, 1KV, 2KV	Bulk		
	D04A7	7.5±1.0					
	D04A0	10±1.0					
	D3EA5	5.0±0.8	3.5 ± 0.5				
	D3EA7	7.5±1.0					
	D3EA0	10±1.0					
	DAND5	5.0 ^{+0.8} _{-0.2}			Taping SPEC. (Ref. to page.10)		Tap. Ammo

50V, 100V, 500V, 1KV, 2KV TEMPERATURE COMPENSATING CERAMIC DISC CAPACITOR	POE-D01-00-E-16	Ver: 16 Page: 7 of 19
---	-----------------	--------------------------

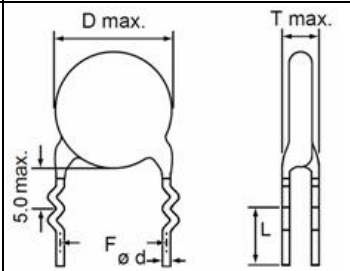
Lead type	SAP P/N (13-17) digits	Lead length (L)	Available rated voltage	Packing	Lead configuration
Lead style : M Double outside kink lead	M05B5	5.0 ± 1.0	50V&100V, 500V, 1KV, 2KV	Bulk	
	M05B7				
	M05B0				
	M04B5	4.0 ± 1.0			
	M04B7				
	M04B0				

※ Lead diameter $\phi = 0.55 \pm 0.05\text{mm}$

※ Phenolic resin coating for 50V/500V/1KV product; Epoxy resin coating for 1KV or 2KV product.

※ **e** (Coating **extension** on leads):

For straight lead style: 1.5mmMax when the rated voltage is 50Vdc & 100Vdc;

2.0mmMax when the rated voltage is 500Vdc and 1KVdc;

3.0mmMax when the rated voltage is 2KVdc.

For kink lead style: not exceed the kink.

※ When $D\phi \geq 11\text{mm}$, only for bulk, but $D\phi \leq 10\text{mm}$ can do Bulk or Taping.



50V, 100V, 500V, 1KV, 2KV TEMPERATURE COMPENSATING CERAMIC DISC CAPACITOR	POE-D01-00-E-16	Ver: 16 Page: 8 of 19
---	-----------------	--------------------------

3. Capacitance value vs. rated voltage, product diameter:

T.C Rate voltage	SL																				
	50V/100V							500V					1KV				2KV				
Dφ	040	050	060	070	080	090	100	050	060	070	080	100	050	060	070	080	060	070	080	110	
D max. (mm)	5.0	6.0	7.0	8.0	9.0	10.0	11.0	6.0	7.0	8.0	9.0	11.0	6.0	7.0	8.0	9.0	7.5	8.5	9.5	12.5	
T max. (mm)	3.5	3.5	3.5	3.5	3.5	3.5	3.5	4.0	4.0	4.0	4.0	4.0	4.5	4.5	4.5	4.5	4.5	4.5	4.5	4.5	
2																					
3																					
4																					
5																					
6																					
7																					
8																					
10																					
12																					
15	150												150				150				
18	180							180					180				180				
20	200							200					200				200				
22	220							220					220				220				
24	240							240					240				240				
27	270							270					270				270				
30	300							300					300				300				
33	330							330					330				330				
36	360							360					360				360				
39	390							390					390				390				
47	470							470					470				470				
51	510							510					510				510				
56	560							560					560				560				
68	680							680					680				680				
75	750							750					750				750				
82	820							820					820				820				
100	101							101					101				101				
120		121							121					121				121			
150		151							151					151				151			
180		181								181				181				181			
200			201							201					201			201			
220			221							221					221			221			
240			241								241						241				
270				271							271						271				
300				301							301						301			301	
330				331							331						331			331	
360				361								361					361				
390				391								391					391				
470					471																
500						501															
510						511															
560						561															
680							681														
750							751														
820							821														
PACKING	TAPING or BULK							TAPING or BULK					TAPING or BULK				TAPING or BULK				BULK
COATING	Phenolic resin							Phenolic resin					Phenolic resin or Epoxy Resin				Epoxy Resin				

4. Marking:

Remarks	SL	
(1). Temp. char.	SL : No marking.	
(2). Rated capacitance	Identified by 3-Figure Code. Ex. 47pF→"47" , 470pF→"471"	
(3). Rated voltage	50V&100V	Marked with code " _ " under the rated capacitance.
	500V	No any marking under the rated capacitance.
	1000V&2000V	Marked with code: 1000V→"1KV" , 2000V→"2KV"
(4). Capacitance tolerance	C: ±0.25pF (For below 5pF) · D: ±0.5pF (For6~10pF) · J: ±5% (For above 10pF)	
(5). Manufacturer's identification	Shall be marked as " UK ", but Dφ≤060 shall be omitted.	
(6). Halogen and Pb free	There is a " _ " marking under the code " V " when the coating resin is Halogen and Pb free Epoxy.	

5. Taping specifications:

* Lead spacing: $F=5.0^{+0.8}_{-0.2}$ (mm)

● 12.7mm pitch/lead spacing 5.0mm taping

Lead code: *BAND5 & *DAND5 & *HAND5

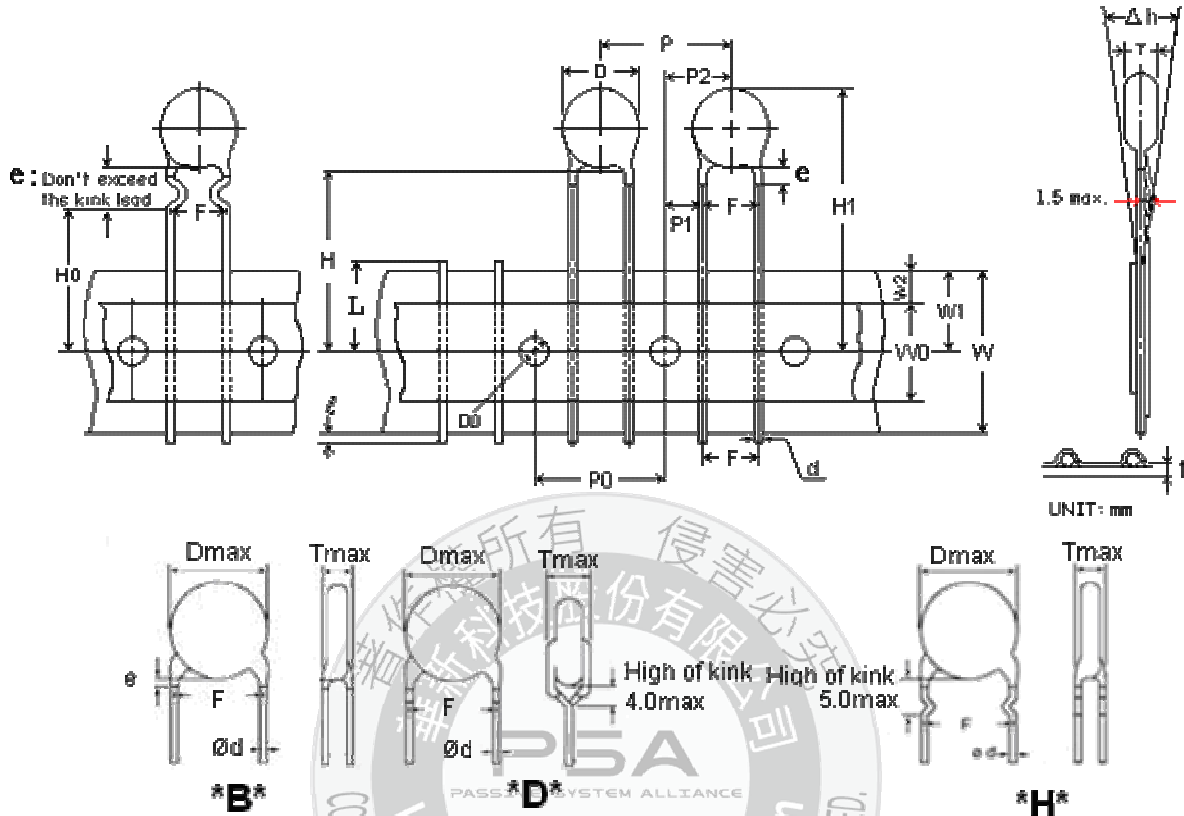

Item	Symbol	Specification		Remarks	
		Value	Tolerance		
Body diameter	D	*	max.	See Section“3. Capacitance value vs. rated voltage, product diameter”.	
Body thickness	T	*	max.		
Lead-wire diameter	d	0.55	±0.05		
Pitch of component	P	12.7	±1.0		
Feed hole pitch	P0	12.7	±0.3	Cumulative pitch error:1.0mm/20 pitch	
Hole center to lead	P1	3.85	±0.7	To be measured at bottom of clinch	
Hole center to component center	P2	6.35	±1.3		
Lead-to-lead distance	F	5.0	+0.8,-0.2		
Component alignment, F-R	△h	0	±2.0		
Tape width	W	18.0	+1.0,-0.5		
Hole-down tape width	W0	8.0	min.		
Hole position	W1	9.0	+0.75,-0.5		
Hole-down tape position	W2	3.0	max.		
Height of component form tape center	For straight lead type	H	20.0	+1.0 -0.5	
	For kinked lead type	H0	16.0	±0.5	
Component height	H1	32.25	max.		
Lead-wire protrusion	l	2.0	max.	Or the end of lead wire may be inside the tape.	
Food hole diameter	D0	4.0	±0.2		
Total tape thickness	t	0.7	±0.2	Ground paper:0.5±0.1mm	
Length of sniped lead	L	11.0	max.		
Coating rundown on leads	e	Please refer to page 6 “e(Coating extension on leads)”.			

6. Packing Baggage :

50V, 100V, 500V, 1KV, 2KV TEMPERATURE COMPENSATING CERAMIC DISC CAPACITOR	POE-D01-00-E-16	Ver: 16 Page: 10 of 19
---	-----------------	---------------------------

6.1 Packing size:

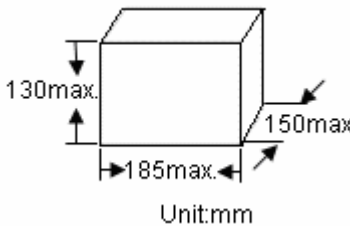
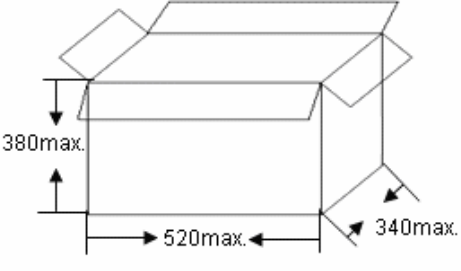
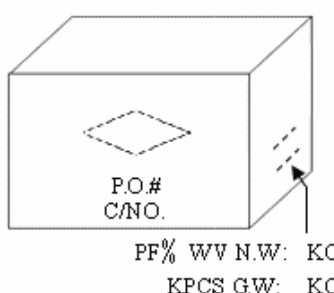
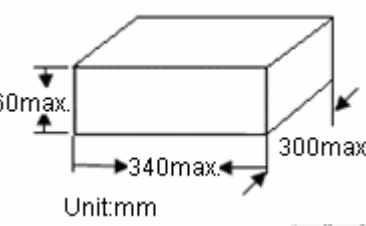
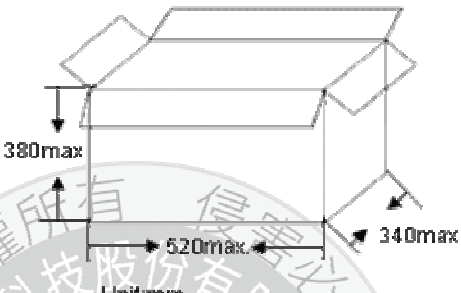
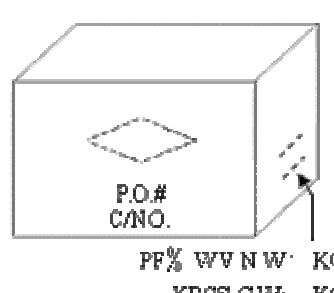
Type	Box	Carton
Bulk	 <p>Unit:mm</p>	  <p>Unit:mm</p> <p>PF% WV N.W: KG KPCS GW: KG</p>
Ammo taping	 <p>Unit:mm</p>	  <p>Unit:mm</p> <p>PF% WV N.W: KG KPCS GW: KG</p>

6.2 Packing quantity:

Packing Type	The code of 14th to 15th in SAP P/N		MPQ (Kpcs/Box)	Remark	
Taping	AN		2	Phenolic resin	
	AN		1.5	Epoxy resin	
Packing Type	Lead length	Size code of 10th to 12th in SAP P/N	MPQ (Kpcs/Bag)	Kpcs/Box	Remark
Bulk	Long lead (L ≥ 16mm)	040~070	1	3	Phenolic resin
		080~100	1	2	Phenolic resin
		050~100	1	2	Epoxy resin
		110~120	0.5	1.5	
	Short lead (L < 16mm)	040~060	1	6	
		070~080	1	4	
		090~100	1	3	
		110~120	1	2	

50V, 100V, 500V, 1KV, 2KV TEMPERATURE COMPENSATING CERAMIC DISC CAPACITOR	POE-D01-00-E-16	Ver: 16 Page: 11 of 19
---	-----------------	---------------------------

7. Specification and test method:

7.1 SCOPE: THIS SPECIFICATION APPLIES TO TEMPERATURE COMPENSATING CERAMIC DISC CAPACITOR.

7.2 TEST CONDITIONS :

UNLESS OTHERWISE SPECIFIED, ALL TESTS SHALL BE OPERATED AT THE STANDARD TEST CONDITIONS OF TEMPERATURE 5°C TO 35°C AND RELATIVE HUMIDITY 45% TO 85%. WHEN FAILS A TEST, RETEST BE OPERATED AT THE CONDITIONS OF TEMPERATURE 25°C ± 2°C, RELATIVE HUMIDITY OF 60% TO 70% AND BAROMETRIC PRESSURE 860 TO 1060 MBAR.

7.3 HANDLE PROCEDURE : TO AVOID UNEXPECT TESTING RESULTS FROM OCCURRING, THE TESTED CAPACITOR MUST BE KEPT AT ROOM TEMPERATURE FOR AT LEAST 30 MINUTES AND COMPLETELY DISCHARGED.

7.4 TEST ITEMS :

ITEM	POST-TEST REQUIREMENTS	TESTING PROCEDURE
APPEARANCE STRUCTURE SIZE	NO ABNORMALITIES	AS SECTION 3.
MARKING		AS STATED IN SECTION 4
WITHSTAND VOLTAGE	BETWEEN TERMINALS: NO ABNORMALITIES	A. BELOW 1KV: 300% RATED VOLTAGE WITH 50mA MAX. CHARGING CURRENT FOR 1~5 SEC. B. 1KV & ABOVE: 200% RATED VOLTAGE WITH 50mA MAX. CHARGING CURRENT FOR 1~5 SEC.
	BETWEEN TERMINAL AND ENCLOSURE : NO ABNORMALITIES	SMALL METALLIC BALLS WITH 1mm DIAMETERS SHALL BE PUT ON A VESSEL AND THE TEST CAPACITOR SHALL BE SUBMERGED EXCEPT 2mm FROM THE TOP OF ITS COMPONENT BODY. THE TEST VOLTAGE SHALL BE APPLIED BETWEEN THE SHORT-CIRCUTED TERMINALS AND THE METALLIC BALLS. (APPLY 1.3KV DC OF RATED VOLTAGE BETWEEN TERMINALS AND ENCLOSURE FOR 1~5 SEC)
INSULATION RESISTANCE	10000 MΩ MIN	INSULATION RESISTANCE SHALL BE MEASURED AT 60±5 SECONDS AFTER APPLIED VOLTAGE (RATED) RATED VOLTAGE: 50V=50V, 100V=100V, 500V & ABOVE=500V
CAPACITANCE	TOLERANCE : C : ±0.25PF D : ±0.50PF J : ±5% K : ±10%	TESTING FREQUENCY : 1 MHZ ± 20% TESTING VOLTAGE : 1.0 VRMS
OPERATING TEMPERATURE RANGE	-25°C ~ +125°C	
Q FACTOR	30 PF & ABOVE	Q ≥ 1000
	BELOW 30PF	Q ≥ 400+20×C
AS ABOVE STIPULATION OF CAPACITANCE		

50V, 100V, 500V, 1KV, 2KV TEMPERATURE COMPENSATING CERAMIC DISC CAPACITOR	POE-D01-00-E-16	Ver: 16 Page: 12 of 19
---	-----------------	---------------------------

ITEM	POST-TEST REQUIREMENTS	TESTING PROCEDURE												
TEMPERATURE CHARACTERISTIC	TEMPERATURE COEFFICIENT : SL :+350~-1000 ppm/°C FOR (+20°C~+85°C)	<p>ACCORDING TO STEP 1 TO 5 IN ORDER, MEASURED CAPACITANCE WHEN TEMPERATURE REACH BALANCE AND TEMPERATURE COEFFICIENT SHALL BE CALCULATED ON THE FOLLOWING FORMULA : PPM/°C =(C2-C1)×10E6/C1(T2-T1)</p> <table border="1"> <thead> <tr> <th>Step</th> <th>1</th> <th>2</th> <th>3</th> <th>4</th> <th>5</th> </tr> </thead> <tbody> <tr> <td>Temp. (°C)</td> <td>25±2</td> <td>20±3</td> <td>25±2</td> <td>85±2</td> <td>25±2</td> </tr> </tbody> </table> <p>NOTE : C1 = CAPACITANCE AS STEP 3 C2 = CAPACITANCE AS STEP 2 OR 4 T1 = TEMPERATURE AS STEP 3 T2 = TEMPERATURE AS STEP 2 OR 4</p>	Step	1	2	3	4	5	Temp. (°C)	25±2	20±3	25±2	85±2	25±2
	Step	1	2	3	4	5								
Temp. (°C)	25±2	20±3	25±2	85±2	25±2									
CAPACITANCE TOLERANCE : WITHIN ±0.2% OR ±0.05PF, WHICHEVER IS LARGE	<p>ACCORDING TO ABOVE STEP 1,3 & 5, CAPACITANCE TOLERANCE SHALL BE CALCULATED ON THE FOLLOWING FORMULA : $\Delta C\%=(G - S)/C1$ NOTE : G = GREATEST CAPACITANCE AS TESTING RESULT OF STEP 1,3 & 5 S = LEAST CAPACITANCE AS TESTING RESULT OF STEP 1,3 & 5 C1 = CAPACITANCE AS STEP 3</p>													
TERMINAL STRENGTH	TENSIBLE STRENGTH : NO BREAKDOWN	<p>WIRE DIA.0.5 M/M. LOADING WEIGHT 0.5 KGS, FOR 10±1 SECONDS. WIRE DIA.0.6 M/M. LOADING WEIGHT 1.0 KGS, FOR 10±1 SECONDS.</p>												
	BENDING STRENGTH : NO BREAKDOWN	<p>WIRE DIA.0.5 mm, LOADING WEIGHT 0.25 KGS. WIRE DIA.0.6 mm, LOADING WEIGHT 0.5 KGS. (BENDING BACK AND FORTH 90 DEGREE TWICE)</p>												
SOLDERING HEAT RESISTANCE	APPEARANCE : NO ABNORMALITIES	<p>LEAD WIRE OR TERMINALS SHALL BE IMMERSUED UP TO 2.0 M/M FORM BODY. (A) BODY DIA. ≤5.0mm: INTO THE MOLTEN SOLDER OF WHICH TEMPERATURE: 260(+5/-0)°C FOR 3.0±0.5 SECONDS. (B) BODY DIA. >5.0mm: INTO THE MOLTEN SOLDER OF WHICH TEMPERATURE 260(+5/-0)°C FOR 5~10 SECONDS.</p>												
	CAP.CHANGE : WITHIN ±2.5% OR ±0.25PF, WHICHEVER IS LARGE.	<p>THEN LEAVE AT STANDARD TEST CONDITIONS FOR 1~2 HOURS, THEN MEASURED. ※WHEN SOLDERING CAPACITOR WITH A SOLDERING IRON, IT SHOULD BE PERFORMED IN FOLLOWING CONDITIONS. TEMPERATURE OF IRON-TIP: 350~400 °C SOLDERING IRON WATTAGE : 50W MAX. SOLDERING TIME : 3.5 SEC. MAX.</p>												
	WITHSTAND VOLTAGE : (BETWEEN TERMINALS) NO ABNORMALITIES													
SOLDERABILITY	LEAD WIRE SHALL BE SOLDERED OVER 75% OF THE CIRCUMFERENTIAL DIRECTION.	<p>TO COMPLY WITH JIS-C-5102 8.4 SOLDER TEMPERATURE245±5°C AND DIPPING TIME 5±0.5 SECONDS FLUX : WEIGHT RATIO OF ROSIN 25%</p>												

50V, 100V, 500V, 1KV, 2KV TEMPERATURE COMPENSATING CERAMIC DISC CAPACITOR	POE-D01-00-E-16	Ver: 16 Page: 13 of 19
---	-----------------	---------------------------

ITEM	POST-TEST REQUIREMENTS	TESTING PROCEDURE
HUMIDITY CHARACTERISTIC	APPEARANCE : NO ABNORMALITIES	CAPACITORS SHALL BE SUBJECTED TO A RELATIVE HUMIDITY OF 90 ~ 95% AT 40 ± 2°C FOR 500(+24/-0) HOURS, THEN DRIED FOR 1~2 HOURS AND MEASURED.
	CAP. CHANGE : SL : WITHIN ±5% OR ±0.5PF, WHICHEVER IS LARGE	
	Q FACTOR : SL : LESS THAN 10PF ==> $Q \geq 200 + 10 \times C$ MORE THAN 10PF AND LESS THAN 30PF => $Q \geq 275 + 5 \times C / 2$ MORE THAN 30PF => $Q \geq 350$	
	INSULATION RESISTANCE : 1000MΩ MIN.	
HUMIDITY LOADING	APPEARANCE : NO ABNORMALITIES	CAPACITORS SHALL BE SUBJECTED TO A RELATIVE HUMIDITY OF 90 ~ 95% AT 40±2°C FOR 500(+24/-0) HOURS WITH RATED VOLTAGE APPLIED (LESS THAN 50mA), THAN DRIED FOR 1~2 HOURS AND MEASURED.
	CAP.CHANGE : SL : WITHIN ±7.5% OR ±0.75PF, WHICHEVER IS LARGE	
	Q FACTOR : SL : LESS THAN 30PF => $Q \geq 100 + 10 \times C / 3$ MORE THAN 30PF => $Q \geq 200$	
	INSULATION RESISTANCE : 500MΩ MIN.	
HIGH TEMPERATURE LOADING	APPEARANCE : NO ABNORMALITIES	CAPACITORS SHALL BE SUBJECTED TO A TEST OF: (A) BELOW 1KV: 200% RATED VOLTAGE WITH 50mA MAX. (B) 1KV & ABOVE: 150% RATED VOLTAGE WITH 50mA MAX. FOR 1000(+48/-0) HOURS AT 125°C ± 2°C (FOR CH & SL) AND THEN DRIED FOR 1~2 HOURS AND MEASURED.
	CAP. CHANGE : SL : WITHIN ±3% OR ±0.3PF, WHICHEVER IS LARGE	
	Q FACTOR : SL : LESS THAN 10PF => $Q \geq 200 + 10 \times C$ MORE THAN 10PF & LESS THAN 30PF => $Q \geq 275 + 5 \times C / 2$ MORE THAN 30PF => $Q \geq 350$	
	INSULATION RESISTANCE : 1000MΩ MIN.	

50V, 100V, 500V, 1KV, 2KV TEMPERATURE COMPENSATING CERAMIC DISC CAPACITOR	POE-D01-00-E-16	Ver: 16 Page: 14 of 19
---	-----------------	---------------------------

ITEM	POST-TEST REQUIREMENTS	TESTING PROCEDURE
TEMPERATURE CYCLING	APPEARANCE : NO ABNORMALITIES	CAPACITORS SHALL BE SUBJECTED TO: -25±3°C (30±3min) → 25°C (3min) → 125±3°C (30±3min) → 25°C (3min) FOR 5 CYCLE.
	CAP. CHANGE : WITHIN ±5% OR ±0.5PF, WHICHEVER IS LARGE	
	D.F. C < 30pF : Q ≥ 275+(5/2)C C ≥ 30pF : Q ≥ 350	
	INSULATION RESISTANCE : 1000 MΩ MIN.	



50V, 100V, 500V, 1KV, 2KV TEMPERATURE COMPENSATING CERAMIC DISC CAPACITOR	POE-D01-00-E-16	Ver: 16 Page: 15 of 19
---	-----------------	---------------------------

8. Cautions & notices:

8.1. Caution (Rating)

I. Operating Voltage

When DC-rated capacitors are to be used in AC or ripple current circuits, be sure to maintain the V_{p-p} value of the applied voltage or the V_{o-p} which contains DC bias within the rated voltage range.

When the voltage is applied to the circuit, starting or stopping may generate irregular voltage for a transit period because of resonance or switching. Be sure to use a capacitor with a rated voltage range that includes these irregular voltages.

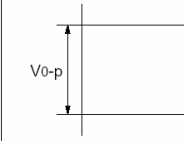
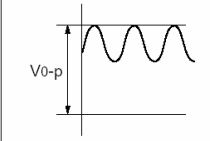
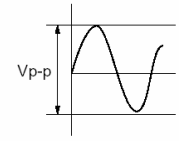
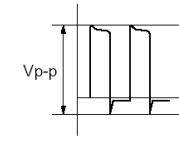
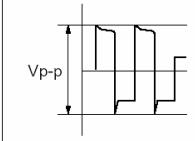
Voltage	DC Voltage	DC+AC Voltage	AC Voltage	Pulse Voltage (1)	Pulse Voltage (2)
Positional measurement					

II. Operating Temperature and Self-generated Heat

Keep the surface temperature of a capacitor below the upper limit of its rated operating temperature range. Be sure to take into account the heat generated by the capacitor itself. When the capacitor is used in a high frequency current, pulse current or similar current, it may self-generate heat due to dielectric loss. The frequency of the applied sine wave voltage should be less than 100kHz. The applied voltage load (*) should be such that the capacitor's self-generated heat is within 20°C at an atmosphere temperature of 25°C. When measuring, use a thermocouple of small thermal capacity-K of $\phi 0.1\text{mm}$ in conditions where the capacitor is not affected by radiant heat from other components or surrounding ambient fluctuations.

Excessive heat may lead to deterioration of the capacitor's characteristics and reliability. (Never attempt to perform measurement with the cooling fan running. Otherwise, accurate measurement cannot be ensured.)

III. Fail-Safe

When capacitor is broken, failure may result in a short circuit. Be sure to provide an appropriate fail-safe function like a fuse on your product if failure would follow an electric shock, fire or fume.

8.2. Caution (Storage and operating condition)

I. Operating and storage environment

The insulating coating of capacitors does not form a perfect seal; therefore, do not use or store capacitors in a corrosive atmosphere, especially where chloride gas, sulfide gas, acid, alkali, salt or the like are present. And avoid exposure to moisture. Before cleaning, bonding or molding this product, verify that these processes do not affect product quality by testing the performance of a cleaned, bonded or molded product in the intended equipment. Store the capacitors where the temperature and relative humidity do not exceed -10 to 40 degrees centigrade and 15 to 85 % for 6 months maximum and use within the period after receiving the capacitors.

FAILURE TO FOLLOW THE ABOVE CAUTIONS MAY RESULT, WORST CASE, IN A SHORT CIRCUIT AND CAUSE FUMING OR PARTIAL DISPERSION WHEN THE PRODUCT IS USED.

8.3. Caution (Soldering and Mounting)

I. Vibration and impact

Do not expose a capacitor or its leads to excessive shock or vibration during use.

II. Soldering

When soldering this product to a PCB/PWB, do not exceed the solder heat resistance specification of the capacitor.

Subjecting this product to excessive heating could melt the internal junction solder and may result in thermal shocks that can crack the ceramic element. When soldering capacitor with a soldering iron, it should be performed in following conditions.

Temperature of iron-tip: 400 degrees C. max.

Soldering iron wattage : 50W max.

Soldering time : 3.5 sec. max.

FAILURE TO FOLLOW THE ABOVE CAUTIONS MAY RESULT, WORST CASE, IN A SHORT CIRCUIT AND CAUSE FUMING OR PARTIAL DISPERSION WHEN THE PRODUCT IS USED.

8.4. Caution (Handling)

Vibration and impact

Do not expose a capacitor or its leads to excessive shock or vibration during use.

FAILURE TO FOLLOW THE ABOVE CAUTIONS MAY RESULT, WORST CASE, IN A SHORT CIRCUIT AND CAUSE FUMING OR PARTIAL DISPERSION WHEN THE PRODUCT IS USED.

8.5. Notice

8.5.1. Notice (Soldering and Mounting)

Cleaning (ultrasonic cleaning)

To perform ultrasonic cleaning, observe the following conditions.

Rinse bath capacity : Output of 20 watts per liter or less.

Rinsing time : 5 min. maximum.

Do not vibrate the PCB/PWB directly.

Excessive ultrasonic cleaning may lead to fatigue destruction of the lead wires.

8.6. Ambient Temp of Allowable Voltage Graph (500Vdc to 2kVdc)

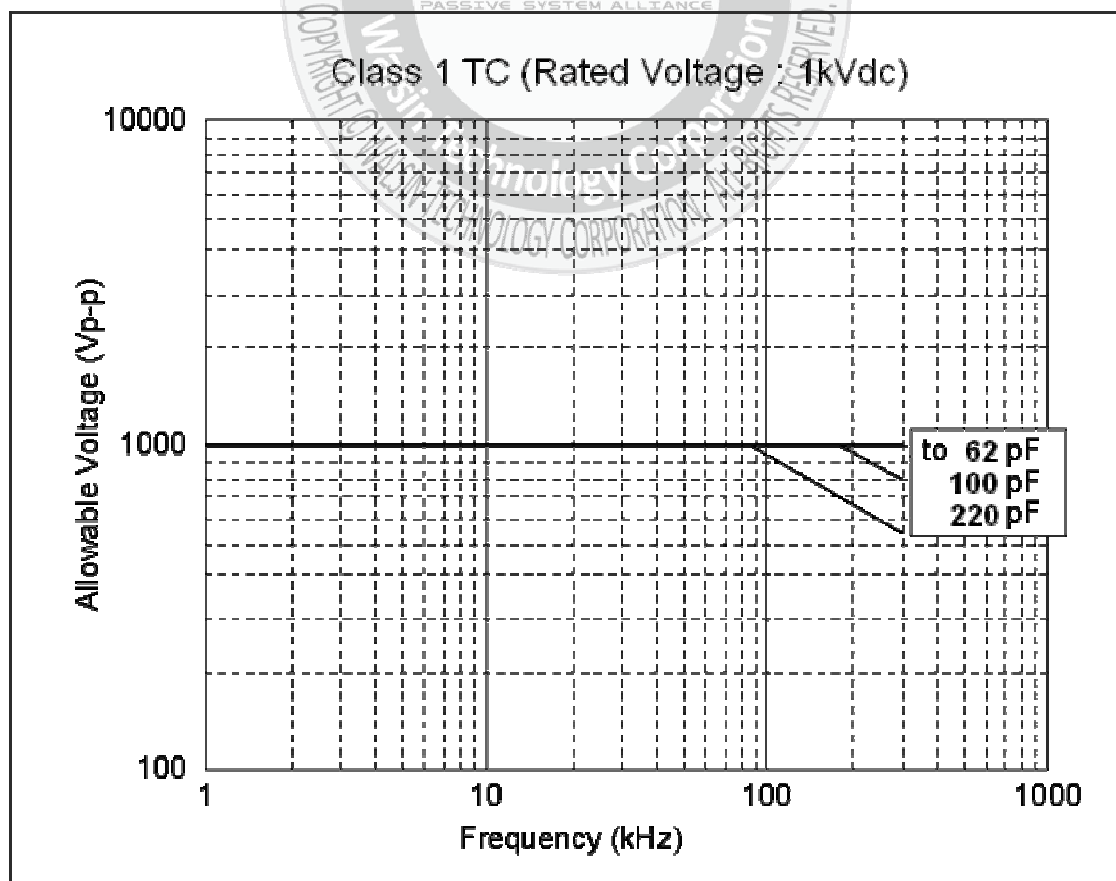
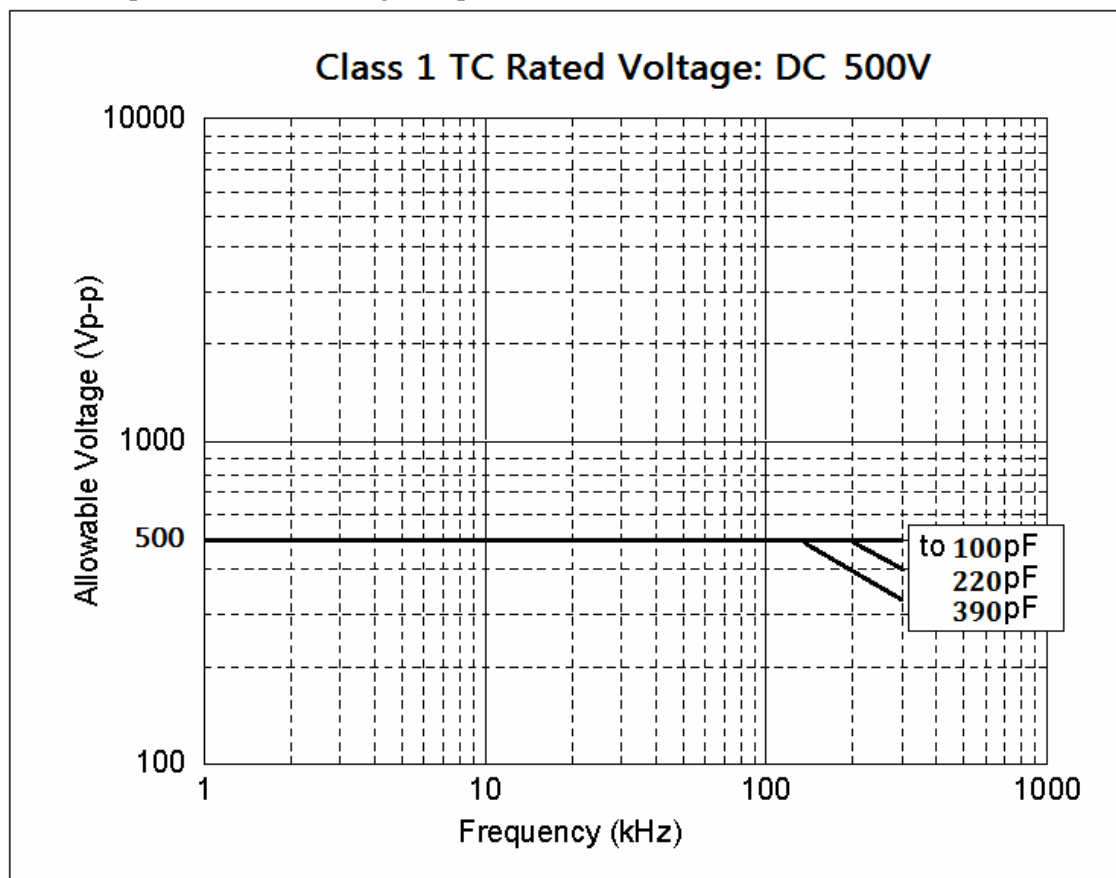

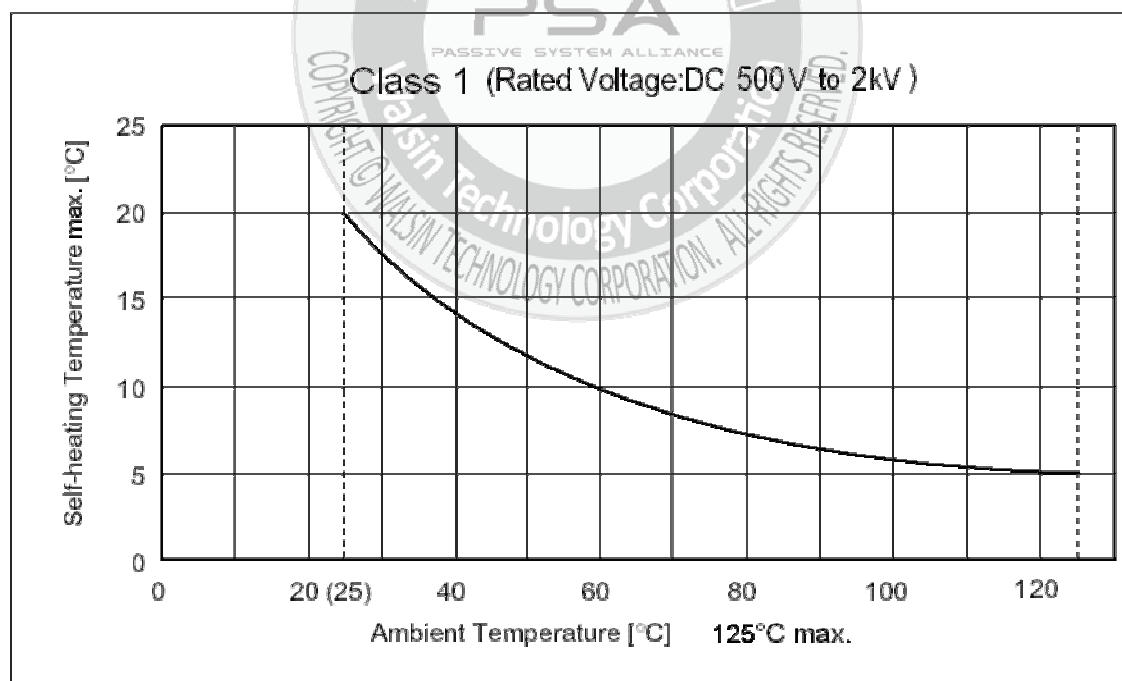
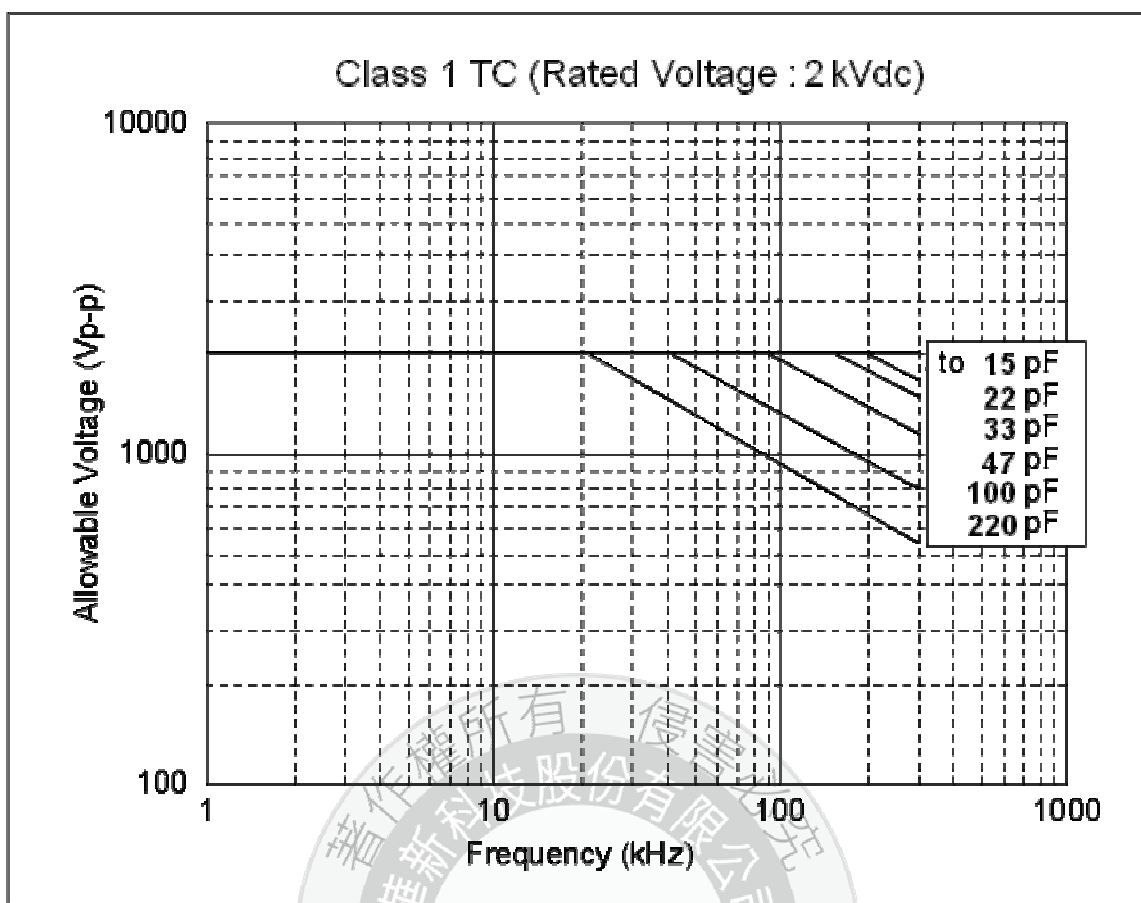

The ambient temperature and the surface temperature of capacitor must be 125°C or lower. (Including self-heating.)

9. Drawing of internal structure and material list:

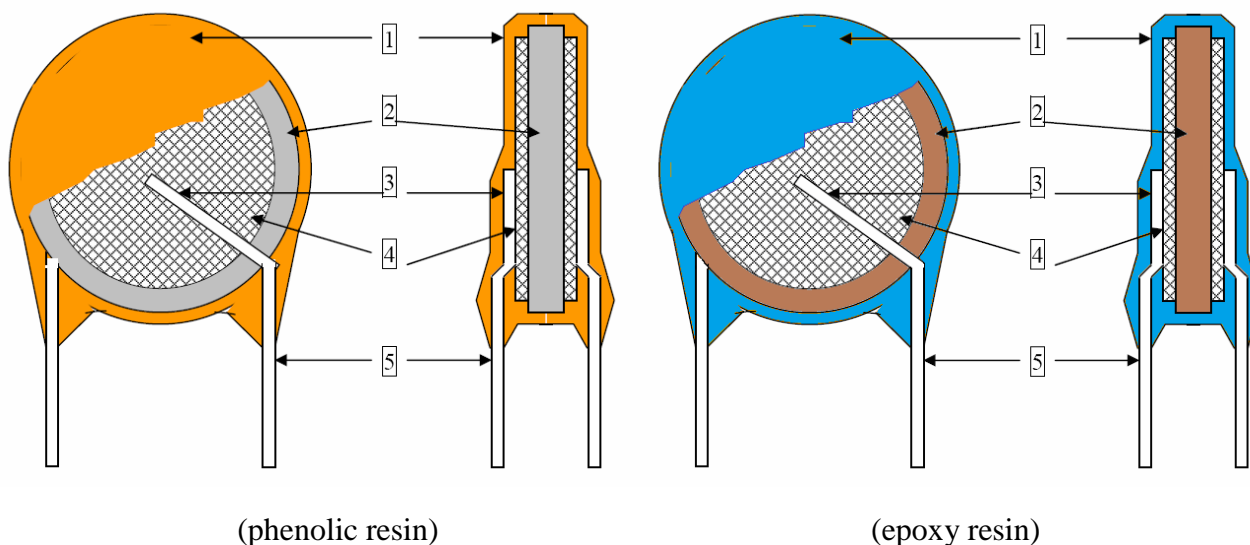

NO.	部位 Part name	材質 Material	構成部份 Component	供應商 Vendor
1	Insulation Coating	Phenolic resin Epoxy resin	Phenolic resin, Filler, Pigment Epoxy resin, SiO ₂ , TiO ₂	Namics Kai Hua
2	Dielectric Element	Ceramic	BaTiO ₃	Hua Xing Wang Feng Fenghua
3	Solder	Tin-silver	Sn97.5-Ag2.5	Huajun Haili
4	Electrodes	Ag	Silver, Glass frit	Daejoo Xinguang
5	Leads wire	Tinned copper clad steel wire	Substrate metal: Fe&Cu Surface plating: Sn 100%	Hengtai Wuhu Taililai

PRODUCT SPECIFICATION

PRODUCT: CERAMIC DISC CAPACITOR

TYPE: 3KV TEMPERATURE COMPENSATING CERAMIC CAPACITOR

CUSTOMER: _____

DOC. NO.: POE-D02-00-E-09

Ver.: 9

APPROVED BY CUSTOMER

VENDOR :

WALSIN TECHNOLOGY CORPORATION

566-1, KAO SHI ROAD, YANG-MEI
TAO-YUAN, TAIWAN

PAN OVERSEAS (GUANGZHOU) ELECTRONIC CO.,LTD.

NO.277,HONG MING ROAD,EASTERN SECTION,
GUANG ZHOU ECONOMIC AND TECHNOLOGY
DEVELOPMENT ZONE,CHINA

MAKER : PAN OVERSEAS (GUANGZHOU) ELECTRONIC CO.,LTD.

NO.277,HONG MING ROAD,EASTERN SECTION,
GUANG ZHOU ECONOMIC AND TECHNOLOGY
DEVELOPMENT ZONE,CHINA



3KV TEMPERATURE COMPENSATING CERAMIC CAPACITOR	POE-D02-00-E-09	Ver: 9 Page: 2 of 15
---	-----------------	-------------------------

Record of change

Date	Version	Description	page
2008.6.3	1	1. F03-00-F-09 (before) → POE-F02-00-F-01 (1 st edition)	
2008.8.22	2	1. Complete lead code 2. Add last SAP code “ H” for halogen and Pb free , epoxy resin.. 3. Remove F(PITCH)=5.0+/-0.8 mm for 3 KV (all lead type)	5-16 2 ,10 15
2008.12.12	3	1. Complete the 13 th to 17 th codes of SAP P/N. 2. Page layout adjustment. 3. Added Marking when the coating resin is Halogen and Pb free Epoxy.	4-5
2009/8/19	4.	1. Change PSA & POE logo to Walsin & POE logo. 2. capacity list → product range	6
2010/9/9	5	1. Review “but Dφ≤6.0 mm shall be omitted.” to “but when the code of body diameter dimension ≤060 shall be omitted.” 2. Add date code on marking (item 7~12).	7 7
2013/5/6	6	1. Review the Lead diameter φ from 0.60 +/-0.06mm to 0.55+/-0.05mm 2. Review the Solderability temperature from 235±5℃ to 245±5℃ , solderability time from 2±0.5s to 5±0.5s.	5,6,8 10
2013/10/18	7	Review the packing specification	11
2016/3/2	8	1. Review the Available lead code of Lead Configuration. 2. Delete the definition about “Old Part No.” 3. Delete 6pF~22pF (Code of diameter dimension is 060) , 24pF (Code of diameter dimension is 070), 27pF~30pF (Code of diameter dimension is 080) and 33pF (Code of diameter dimension is 090)for P/N CH 3KV. 4. Review 9. Drawing of internal structure and material list	5 5,7 6 15
2016/11/3	9	1. Delete “CH” series. 2. Delete 5pF~8pF (Code of diameter dimension is 060) for P/N SL 3KV.	4,6,7,10~13,15 6

3KV TEMPERATURE COMPENSATING CERAMIC CAPACITOR	POE-D02-00-E-09	Ver: 9 Page: 3 of 15
---	-----------------	-------------------------

Table of Contents

No.	Item	Page
1	Part number for SAP system	4/15
2	Mechanical	5/15
3	Capacitance value vs. Rate voltage, product diameter	6/15
4	Marking	7/16
5	Taping Format	8/16
6	Specification and test method	9/16~11/15
7	Packing specification	12/15
8	Notices	13/15~14/15
9	Drawing of internal structure and material list	15/15



3KV TEMPERATURE COMPENSATING CERAMIC CAPACITOR	POE-D02-00-E-09	Ver: 9 Page: 4 of 15
---	-----------------	-------------------------

1. Part number for SAP system :

SL 3 0 2 1 0 0 J 0 6 0 B 2 0 C 7 H
 (1) (2) (3) (4) (5) (6) (7) (8) (9) (10)

- (1)Temperature Characteristic : SL:+350~-1000ppm/°C
- (2)Rate Voltage(identified by 3-figure code) : 302=3KVDC
- (3)Rate Capacitance (identified by code) : ex. 100=10pF, 101=100pF
- (4)Tolerance of Capacitance : J= ±5%(For above 10pF)
- (5)Nominal body diameter dimension (Ref.to page.6 Dφ Code spec.) .
- (6)Lead Style : Refer to “2. Mechanical”.
- (7)Packing mode and lead length (identified by 2-figure code) :

Taping Code	Description
AF	Box and Pitch : 15.0 mm
AM	Box and Pitch : 25.4 mm

Bulk Code	Description
3E	Lead length : 3.5mm
04	Lead length : 4.0mm
4E	Lead length : 4.5mm
20	Lead length : 20.0mm

- (8)Length tolerance :

Code	Description
A	±0.5 mm (only for kink lead type)
B	±1.0 mm
C	MIN.
D	Taping special purpose

- (9)Lead Pitch :

Code	Description
7	7.5±1 mm
0	10±1 mm

- (10)Epoxy Resin Code :

Code	Description
B	Pb free, Epoxy Resin
H	Halogen and Pb free, epoxy resin.

3KV TEMPERATURE COMPENSATING CERAMIC CAPACITOR	POE-D02-00-E-09	Ver: 9 Page: 5 of 15
---	-----------------	-------------------------

2. Mechanical:

Available lead code (Epoxy Resin Coating)- (unit: mm)

Lead type	SAP P/N (13-17)digits	Pitch (F)	Lead Length (L)	Packing	Lead Configuration
Lead style : B Straight long lead	B20C7	7.5 ± 1.0	20 MIN.	Bulk	
	B20C0	10 ± 1.0	20 MIN.		
	BAFD7	7.5 ± 1.0	Refer to “5. Taping format”	Tap. Ammo	
	BAMD0	10 ± 1.0			
Lead style : L Straight short lead	L03B7	7.5 ± 1.0	3.0 ± 1.0	Bulk	
	L4EB7	7.5 ± 1.0	4.5 ± 1.0		
	L05B7	7.5 ± 1.0	5.0 ± 1.0		
	L10B7	7.5 ± 1.0	10.0 ± 1.0		
	L03B0	10 ± 1.0	3.0 ± 1.0		
	L4EB0	10 ± 1.0	4.5 ± 1.0		
	L05B0	10 ± 1.0	5.0 ± 1.0		
Lead style : X Outside kink lead	X3EA7	7.5 ± 1.0	3.5 ± 0.5	Bulk	
	X04A7	7.5 ± 1.0	4.0 ± 0.5		
	X05B7	7.5 ± 1.0	5.0 ± 1.0		
	X3EA0	10 ± 1.0	3.5 ± 0.5		
	X04A0	10 ± 1.0	4.0 ± 0.5		
	X05B0	10 ± 1.0	5.0 ± 1.0		
	XAFD7	7.5 ± 1.0	Refer to “5. Taping format”	Tap. Ammo	
	XAMD0	10 ± 1.0			
Lead style : D Vertical kink short lead	D3EA7	7.5 ± 1.0	3.5 ± 0.5	Bulk	
	D04A7	7.5 ± 1.0	4.0 ± 0.5		
	D3EA0	10 ± 1.0	3.5 ± 0.5		
	D04A0	10 ± 1.0	4.0 ± 0.5		
	DAFD7	7.5 ± 1.0	Refer to “5. Taping format”		
	DAMD0	10 ± 1.0			
Lead style : H Inside kink lead	H3EA0	10.0±1.0	3.5±0.5 mm	Bulk	
	HAFD0	Refer to “5. Taping format”		Tap. Ammo	
	HAMD0				
Lead style : M Double outside kink lead	M04B7	7.5 ± 1.0	4.0 ± 1.0	Bulk	
	M04B0	10 ± 1.0	4.0 ± 1.0		

* Lead diameter Φd: 0.55+/-0.05mm

* e (Coating **extension** on leads): 3.0mmMax for straight lead lead style, not exceed the kink for kink lead.

3KV TEMPERATURE COMPENSATING CERAMIC CAPACITOR	POE-D02-00-E-09	Ver: 9 Page: 6 of 15
---	-----------------	-------------------------

3. Capacitance value vs. Rate voltage, product diameter :

Manufacturing product range Cap. Value vs. Rate voltage, product diameter & type		SL		
		Photo		
T.C.	SL (CLASS I, Temperature:+20℃~+85℃, T.C.C.: +350 ~ -1000ppm)			
Rate voltage	3KV			
Dφ(Code)	060	070	080	
D max. (mm)	7.5	8.5	9.5	
T max. (mm)	5.0	5.0	5.0	
2				
3				
4				
5				
6				
7				
8				
10	100			
12	120			
15	150			
18	180			
20	200			
22	220			
24	240			
27	270			
30	300			
33	330			
36	360			
39	390			
47		470		
51		510		
56		560		
62		620		
68		680		
75			750	
82			820	
100			101	
φd (mm)	0.5 5±0.05			
PACKING	TAPING or BULK			
COATING	Epoxy Resin			

3KV TEMPERATURE COMPENSATING CERAMIC CAPACITOR	POE-D02-00-E-09	Ver: 9 Page: 7 of 15
---	-----------------	-------------------------

4. Marking :

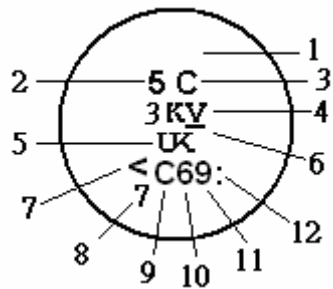

1. Temperature characteristic	2. Nominal capacitance	3. Capacitance tolerance	4. Rated voltage	5. Manufacturer's identification	6. Halogen and Pb free
SL : No marking	Identified by 3-figure code 1. when Cap.≥100pF Ex. 120pF → "121" 2. When Cap<100pF, marked actual Cap. value. Ex. 22pF → "22"	J: ±5% (For above 10pF)	3000V : Be marked "3kV"	Shall be marked as "UK", but when the code of body diameter dimension ≤060 shall be omitted.	When the epoxy resin is Halogen and Pb free, there is a "-" marking.
Definition of date code marking:					
7. Supplier of Epoxy	8. No. of test equipment	9. Factory of manufacture	10. Year of manufacture	11. Month of manufacture	12. Week of manufacture by month
<: K-company , : P-company	1~9: No.1~No.9, J: No.10, K: No.11, L: No.12	C: Factory of POEGZ	1: 2011, 2: 2012, 3: 2013, 4: 2014, 5: 2015, 6: 2016, 7: 2017, ...	1~9: January~September, O: October, N: November, D: December	week 1: - week 2: · week 3: : week 4: ' week 5: ;

3KV TEMPERATURE COMPENSATING CERAMIC CAPACITOR	POE-D02-00-E-09	Ver: 9 Page: 8 of 15
---	-----------------	-------------------------

5. Taping Format:

- 15mm pitch/lead spacing 7.5mm taping

Lead Code: *BAFD7 & *DAFD7 & *HAFD7 & *XAFD7

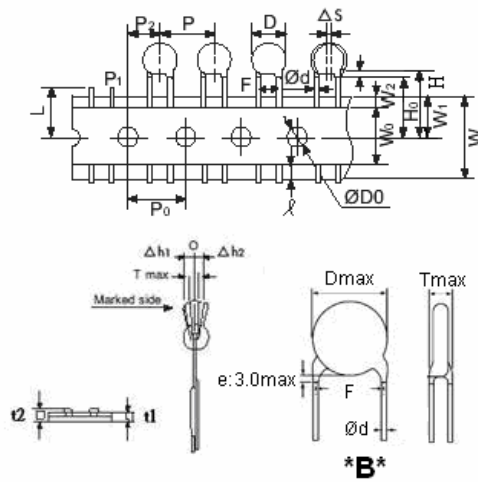

- 25.4mm pitch/lead spacing 10.0mm taping

Lead Code: *DAMD0 & *XAMD0 & *HAMD0 & *BAMD0

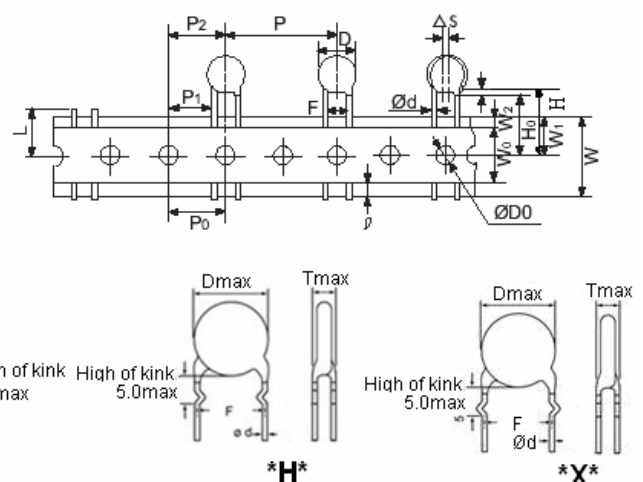

POE Part Number		*BAFD7	*DAFD7 *HAFD7 *XAFD7	*BAMD0 *DAMD0 *HAMD0 *XAMD0
Item	Symbol	Dimensions (mm)		Dimensions (mm)
Pitch of component	P	15.0		25.4
Pitch of sprocket	P0	15.0±0.3		12.7±0.3
Lead spacing	F	7.5±1.0		10.0±1.0
Length from hole center to component center	P2	7.5±1.5		12.7 ± 1.5
Length from hole center to lead	P1	3.75±1.0		7.7±1.5
Body diameter	D	See the “3. Capacitance value vs. Rate voltage, product diameter”		
Deviation along tape, left or right	ΔS	0±2.0		
Carrier tape width	W	18.0 +1/-0.5		
Position of sprocket hole	W1	9.0±0.5		
Lead distance between the kink and center of sprocket hole	H0	18.0+2.0/-0		18.0+2.0/-0 For: *DAMD0 *HAMD0 *XAMD0
Lead distance between the bottom of body and the center of sprocket hole	H	20.0+1.5/-1.0		20.0+1.5/-1.0 For: *BAMD0
Protrusion length	ℓ	2.0max (Or the end of lead wire may be inside the tape.)		
Diameter of sprocket hole	D0	4.0±0.2		
Lead diameter	φd	0.55 ±0.05		
Total tape thickness	t1	0.6±0.3		
Total thickness, tape and lead wire	t2	1.5 max.		
Deviation across tape	Δh1	2.0 max.		
	Δh2	2.0 max.		
Portion to cut in case of defect	L	11.0 max.		
Hole-down tape width	W0	11.5min		
Hole-down tape distortion	W2	1.5±1.5		
Coating extension on leads	e	3.0 max for straight lead style; Not exceed the kink leads for kink lead.		
Body thickness	T	See the “3. Capacitance value vs. Rate voltage, product diameter”		

3KV TEMPERATURE COMPENSATING CERAMIC CAPACITOR	POE-D02-00-E-09	Ver: 9 Page: 9 of 15
---	-----------------	-------------------------

6. Specification and test method:

6.1 SCOPE: THIS SPECIFICATION APPLIES TO TEMPERATURE COMPENSATING CONSTANT, 3KV CERAMIC CAPACITOR.

6.2 TEST CONDITIONS:

UNLESS OTHERWISE SPECIFIED, ALL TESTS SHALL BE OPERATED AT THE STANDARD TEST CONDITIONS OF TEMPERATURE 5°C TO 35°C AND RELATIVE HUMIDITY 45% TO 85%. WHEN FAILS A TEST, RETEST BE OPERATED AT THE CONDITIONS OF TEMPERATURE 25°C ± 2°C, RELATIVE HUMIDITY OF 60% TO 70% AND BAROMETRIC PRESSURE 860 TO 1060 MBAR.

6.3 HANDLE PROCEDURE: TO AVOID UNEXPECT TESTING RESULTS FROM OCCURING, THE TESTED CAPACITOR MUST BE KEPT AT ROOM TEMPERATURE FOR AT LEAST 30 MINUTES AND COMPLETELY DISCHARGED.

6.4 TEST ITEMS:

ITEM	POST-TEST REQUIREMENTS	TESTING PROCEDURE
APPEARANCE STRUCTURE SIZE	NO ABNORMALITIES	
MARKING		AS STATED IN SECTION 4
WITHSTAND VOLTAGEN	BETWEEN TERMINALS: NO ABNORMALITIES	2 TIMES OF THE RATED VOLTAGE. TEST VOLTAGE : 6KVDC, 1~5 SEC, WITH 50mA MAX. CHARGING CURRENT
	BETWEEN TERMINAL AND ENCLOSURE : NO ABNORMALITIES	SMALL METALLIC BALLS WITH 1mm DIAMETERS SHALL BE PUT ON A VESSEL AND THE TEST CAPACITOR SHALL BE SUBMERGED EXCEPT 2mm FROM THE TOP OF ITS COMPONENT BODY. THE TEST VOLTAGE SHALL BE APPLIED BETWEEN THE SHORT-CIRCUITED TERMINALS AND THE METALLIC BALLS. (APPLY 1.3KV DC OF RATED VOLTAGE BETWEEN TERMINALS AND ENCLOSURE FOR 1~5 SEC)
INSULATION RESISTANCE	10000 MΩ MIN	INSULATION RESISTANCE SHALL BE MEASURED AT 60±5 SECONDS AFTER RATED VOLTAGE APPLIED. RATED VOLTAGE : 500VDC
CAPACITANCE	TOLERANCE : J : ±5%, K : ±10%	TESTING FREQUENCY: 1MHZ ± 20 % TESTING TEMPERATURE: 25 ± 2°C TESTING VOLTAGE: 1.0 ± 0.2 VRMS
TEMPERATURE RANGE	OPERATING TEMPERATURE : -25°C ~ +125°C	
Q FACTOR)	30PF & ABOVE ≥ 1000	BELOW 30PF ≥ 400+20×C
TERMINAL STRENGTH	TENSIBLE STRENGTH: NO BREAKDOWN	WIRE DIA.0.5mm, LOADING WEIGHT 0.5KG FOR 10±1 SECONDS. WIRE DIA.0.6mm, LOADING WEIGHT 1.0KG FOR 10±1 SECONDS
	BENDING STRENGTH: NO BREAKDOWN	WIRE DIA.0.5mm, LOADING WEIGHT 0.25 KG. WIRE DIA.0.6mm, LOADING WEIGHT 0.5 KG. (BENDING BACK AND FORTH 90 DEGREE TWICE)

3KV TEMPERATURE COMPENSATING CERAMIC CAPACITOR	POE-D02-00-E-09	Ver: 9 Page: 10 of 15
---	-----------------	--------------------------

ITEM	POST-TEST REQUIREMENTS	TESTING PROCEDURE
TEMPERATURE CHARACTERISTIC	TEMPERATURE COEFFICIENT: SL: +350 ~ -1000PPM/°C	ACCORDING TO STEP 1 TO 5 IN ORDER, MEASURED CAPACITANCE WHEN TEMPERATURE REACH BALANCE AND TEMPERATURE COEFFICIENT SHALL BE CALCULATED ON THE FOLLOWING FORMULA : $\text{PPM}/^{\circ}\text{C} = (\text{C2}-\text{C1}) \times 10\text{E}6 / \text{C1}(\text{T2}-\text{T1})$ STEP 1,3,5: 25°C STEP 4: 85°C STEP 2: CH:-25°C ; SL:20°C NOTE : C1 = CAPACITANCE AS STEP 3 C2 = CAPACITANCE AS STEP 2 OR 4 T1 = TEMPERATURE AS STEP 3 T2 = TEMPERATURE AS STEP 2 OR 4
	CAPACITANCE TOLERANCE: SL: WITHIN ±0.2% OR ±0.05PF, WHICHEVER IS LARGE	ACCORDING TO ABOVE STEP 1,3 & 5, CAPACITANCE TOLERANCE SHALL BE CALCULATED ON THE FOLLOWING FORMULA : $\Delta\text{C}\% = (\text{G} - \text{S}) / \text{C1}$ NOTE: G = GREATEST CAPACITANCE AS TESTING RESULT OF STEP 1,3 & 5 S = LEAST CAPACITANCE AS TESTING RESULT OF STEP 1,3 & 5 C1 = CAPACITANCE AS STEP 3
SOLDERING HEAT RESISTANCE	APPEARANCE: NO ABNORMALITIES	LEAD WIRE OR TERMINALS SHALL IMMERSE UP TO 2.0 M/M FORM BODY. INTO THE MOLTEN SOLDER OF WHICH TEMPERATURE: 260(+5/-0)°C FOR 5~10 SECONDS. THEN LEAVE AT STANDARD TEST CONDITIONS FOR 24±2 HOURS, THEN MEASURED. ※WHEN SOLDERING CAPACITOR WITH A SOLDERING IRON, IT SHOULD BE PERFORMED IN FOLLOWING CONDITIONS. TEMPERATURE OF IRON-TIP: 350~400 °C SOLDERING IRON WATTAGE : 50W MAX. SOLDERING TIME : 3.5 SEC. MAX.
	CAP.CHANGE: SL WITHIN ±2.5% OR ±0.25PF, WHICHEVER IS LARGE.	
	WITHSTAND VOLTAGE: (BETWEEN TERMINALS) NO ABNORMALITIES	
SOLDERABILITY	LEAD WIRE SHALL BE SOLDERED OVER 75% OF THE CIRCUMFERENTIAL DIRECTION.	TO COMPLY WITH JIS-C-5102 8.4 SOLDER TEMPERATURE 245±5°C AND DIPPING TIME 5±0.5 SECONDS FLUX : WEIGHT RATIO OF POSIN 25%

3KV TEMPERATURE COMPENSATING CERAMIC CAPACITOR	POE-D02-00-E-09	Ver: 9 Page: 11 of 15
---	-----------------	--------------------------

ITEM	POST-TEST REQUIREMENTS	TESTING PROCEDURE
HUMIDITY CHARACTERISTIC (STABLE SITUATION)	APPEARANCE: NO ABNORMALITIES	CAPACITORS SHALL BE SUBJECTED TO A RELATIVE HUMIDITY OF 90 ~ 95% AT 40±2°C FOR 500(+24/-0) HOURS. THEN DRIED FOR 1~2 HOURS AND MEASURED.
	CAP.CHANGE: SL WITHIN ±5% OR ±0.5PF, WHICHEVER IS LARGE.	
	Q FACTOR: SL LESS THAN 10PF => $Q \geq 200 + 10 \times C$ MORE THAN 10PF AND LESS THAN 30PF => $Q \geq 275 + 5 \times C/2$ MORE THAN 30PF => $Q \geq 350$	
	INSULATION RESISTANCE: 1000MΩ MIN.	
HUMIDITY LOADING	APPEARANCE: NO ABNORMALITIES	CAPACITORS SHALL BE SUBJECTED TO A RELATIVE HUMIDITY OF 90 ~ 95% AT 40 ± 2°C FOR 500(+24/-0) HOURS WITH RATED VOLTAGE APPLIED WITH 50mA MAX. THEN DRIED FOR 1~2 HOURS AND MEASURED.
	CAP.CHANGE: SL WITHIN ±7.5% OR ±0.75PF, WHICHEVER IS LARGE.	
	Q FACTOR: SL LESS THAN 30PF => $Q \geq 100 + 10 \times C/3$ MORE THAN 30PF => $Q \geq 200$	
	INSULATION RESISTANCE: 500 MΩ MIN	
HIGH TEMPERATURE LOADING	APPEARANCE : NO ABNORMALITIES	150% RATED VOLTAGE WITH 50mA max. FOR 1000(+48/-0) HOURS AT 125±3°C AND THEN DRIED FOR 1~2 HOURS AND MEASURED.
	CAP.CHANGE : WITHIN ±3% OR ±0.3PF, WHICHEVER IS LARGE.	
	Q FACTOR : SL : LESS THAN 10PF ==> $Q \geq 200 + 10 \times C$ MORE THAN 10PF AND LESS THAN 30PF ==> $Q \geq 275 + 5 \times C/2$ MORE THAN 30PF ==> $Q \geq 350$	
	INSULATION RESISTANCE: 1000 MΩ MIN.	

3KV TEMPERATURE COMPENSATING CERAMIC CAPACITOR	POE-D02-00-E-09	Ver: 9 Page: 12 of 15
---	-----------------	--------------------------

7.Packing Baggage :

7.1 Packing size:

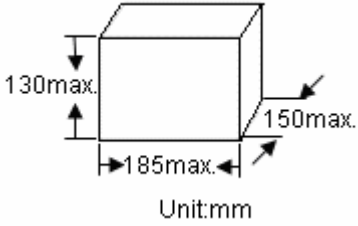
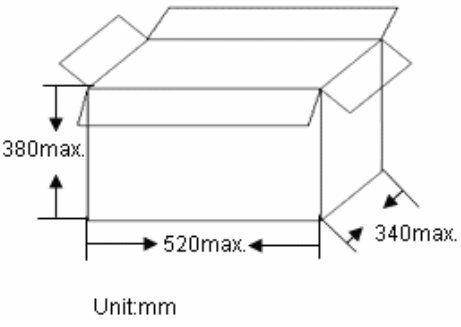
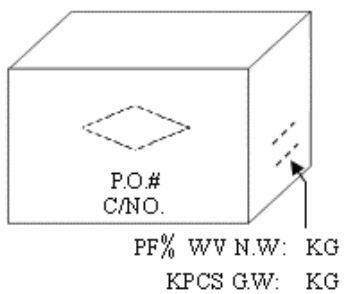
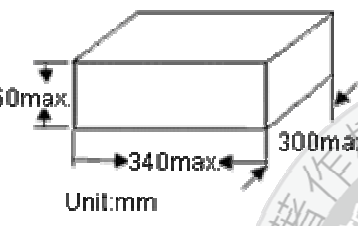
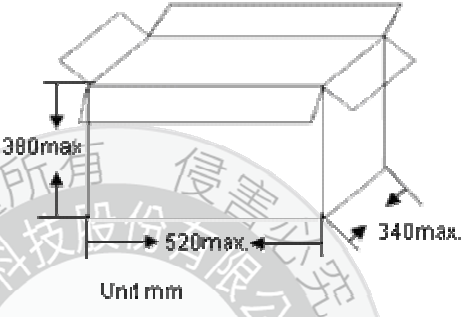
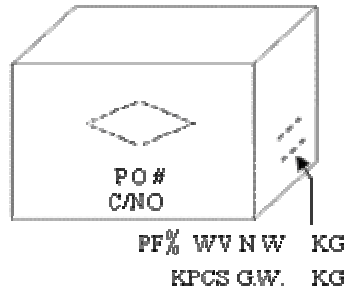
Type	Box	Carton	
Bulk	 <p>Unit:mm</p>	 <p>Unit:mm</p>	 <p>P.O.# C/NO. PF% WV N.W: KG KPCS G.W: KG</p>
Ammo taping	 <p>Unit:mm</p>	 <p>Unit:mm</p>	 <p>P.O.# C/NO. PF% WV N.W: KG KPCS G.W: KG</p>

7.2 Packing quantity:

Packing type	The code of 14th to 15th in SAP P/N	MPQ (Kpcs/ Box)
Taping	AF	1
	AM	0.5

Packing type	MPQ (Kpcs/Bag)
Bulk	1

8. Notices:

8.1 Operating Voltage:

When DC-rated capacitors are to be used in AC or ripple current circuits, be sure to maintain the V_{p-p} value of the applied voltage or the V_{o-p} which contains DC bias within the rated voltage range.

When the voltage is applied to the circuit, starting or stopping may generate irregular voltage for a transit period because of resonance or switching. Be sure to use a capacitor with a rated voltage range that includes these irregular voltages.

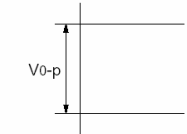
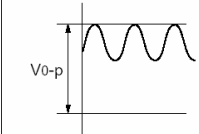
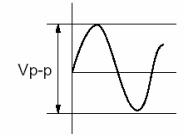
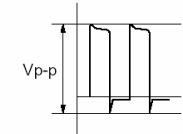
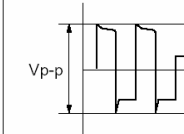
Voltage	DC Voltage	DC+AC Voltage	AC Voltage	Pulse Voltage (1)	Pulse Voltage (2)
Positional measurement					

8.2 Operating Temperature and Self-generated Heat

Keep the surface temperature of a capacitor below the upper limit of its rated operating temperature range. Be sure to take into account the heat generated by the capacitor itself. When the capacitor is used in a high frequency current, pulse current or similar current, it may self-generate heat due to dielectric loss. The frequency of the applied sine wave voltage should be less than 100kHz. The applied voltage load (*) should be such that the capacitor's self-generated heat is within 20°C at an atmosphere temperature of 25°C. When measuring, use a thermocouple of small thermal capacity-K of $\phi 0.1\text{mm}$ in conditions where the capacitor is not affected by radiant heat from other components or surrounding ambient fluctuations.

Excessive heat may lead to deterioration of the capacitor's characteristics and reliability. (Never attempt to perform measurement with the cooling fan running. Otherwise, accurate measurement cannot be ensured.)

8.3 Fail-Safe

When capacitor is broken, failure may result in a short circuit. Be sure to provide an appropriate fail-safe function like a fuse on your product if failure would follow an electric shock, fire or fume.

8.4 Operating and storage environment

The insulating coating of capacitors does not form a perfect seal; therefore, do not use or store capacitors in a corrosive atmosphere, especially where chloride gas, sulfide gas, acid, alkali, salt or the like are present. And avoid exposure to moisture. Before cleaning, bonding or molding this product, verify that these processes do not affect product quality by testing the performance of a cleaned, bonded or molded product in the intended equipment. Store the capacitors where the temperature and relative humidity do not exceed -10 to 40 degrees centigrade and 15 to 85 % for 6 months maximum and use within the period after receiving the capacitors.

FAILURE TO FOLLOW THE ABOVE CAUTIONS MAY RESULT, WORST CASE, IN A SHORT CIRCUIT AND CAUSE FUMING OR PARTIAL DISPERSION WHEN THE PRODUCT IS USED.

8.5 Vibration and impact

Do not expose a capacitor or its leads to excessive shock or vibration during use.

8.6 Soldering

When soldering this product to a PCB/PWB, do not exceed the solder heat resistance specification of the capacitor. Subjecting this product to excessive heating could melt the internal junction solder and may result in thermal shocks that can crack the ceramic element. When soldering capacitor with a soldering iron, it should be performed in following conditions.

Temperature of iron-tip: 400 degrees C. max.

Soldering iron wattage : 50W max.

Soldering time : 3.5 sec. max.

FAILURE TO FOLLOW THE ABOVE CAUTIONS MAY RESULT, WORST CASE, IN A SHORT CIRCUIT AND CAUSE FUMING OR PARTIAL DISPERSION WHEN THE PRODUCT IS USED.

8.7 Cleaning (ultrasonic cleaning)

To perform ultrasonic cleaning, observe the following conditions.

Rinse bath capacity : Output of 20 watts per liter or less.

Rinsing time : 5 min. maximum.

Do not vibrate the PCB/PWB directly.

Excessive ultrasonic cleaning may lead to fatigue destruction of the lead wires.

8.8 Rating

Capacitance change of capacitor

I. Class 1 series (Temp. Char. SL)

Capacitance might change a little depending on the surrounding temperature or an applied voltage.

Please contact us if you intend to use this product in a strict time constant circuit.

9.Drawing of internal structure and material list:

產品結構圖

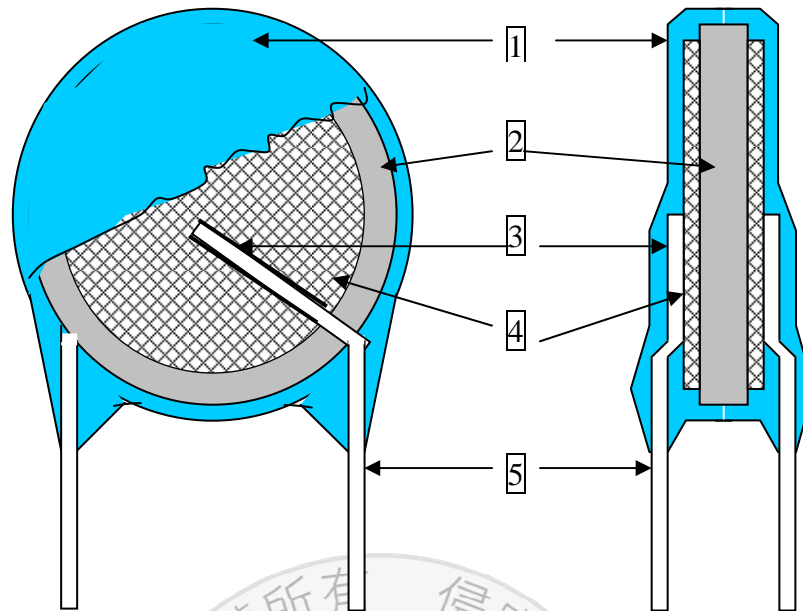

Remarks :

No.	Part name	Material	Model/Type	Component
1	Insulation Coating	Epoxy polymer	1.EF-150C 2.EF-150(HF) 3.PCE-210 2.PCE-300(HF)	Epoxy resin、Pigment (Blue / UL 94 V-0 /) The minimum thickness of coating (reinforced insulation) is 0.4mm
2	Dielectric Element	Ceramic	SL	BaTiO ₃
3	Solder	Tin-silver	Sn96.5-Ag3-Cu0.5	Sn96.5-Ag3-Cu0.5
4	Electrodes	Ag	1.SP-160PL 2.SP-260PL	Silver、Glass frit
5	Leads wire	Tinned copper clad steel wire	0.55±0.05 mm	Substrate metal: Fe & Cu Surface plating: Sn 100%(3~7μm)

PRODUCT SPECIFICATION

PRODUCT: CERAMIC DISC CAPACITOR

TYPE: 6KV TEMPERATURE COMPENSATING CERAMIC CAPACITOR

CUSTOMER: _____

DOC. NO.: POE-D03-00-E-09

Ver.: 9

APPROVED BY CUSTOMER

VENDOR :

WALSIN TECHNOLOGY CORPORATION

566-1, KAO SHI ROAD, YANG-MEI
TAO-YUAN, TAIWAN

PAN OVERSEAS (GUANGZHOU) ELECTRONIC CO.,LTD.

NO.277,HONG MING ROAD,EASTERN SECTION,
GUANG ZHOU ECONOMIC AND TECHNOLOGY
DEVELOPMENT ZONE,CHINA

MAKER : PAN OVERSEAS (GUANGZHOU) ELECTRONIC CO.,LTD.

NO.277,HONG MING ROAD,EASTERN SECTION,
GUANG ZHOU ECONOMIC AND TECHNOLOGY
DEVELOPMENT ZONE,CHINA



Record of change

Date	Version	Description	page
2008.6.3	1	1. D14-00-E-06 (before) → POE-D03-00-E-01(1 st edition)	
2008.8.22	2	1. Complete lead code 3. Add last SAP code “ H” for halogen and Pb free , epoxy resin.	5-6 2
2008.12.12	3	1. Complete the 13 th to 17 th codes of SAP P/N. 2. Page layout adjustment. 3. Added marking when the coating resin is Halogen and Pb free Epoxy.	4-5
2009/8/19	4	1. Change PSA & POE logo to Walsin & POE logo. 2. Revised WITHSTAND VOLTAGEN and operating temperature from -25℃~+85℃ to -25℃~+125℃ 3. capacity list → product range	all 9 6
2010/9/9	5	1. Review “but Dφ≤6.0 mm shall be omitted.” to “but when the code of body diameter dimension ≤060 shall be omitted.” 2. Delete “1.5000V : Be marked “5kV”” 3. Add date code on marking (item 7~12).	7 7 7
2013/5/6	6	1. Review the Lead diameter φ from 0.60 +/-0.06mm to 0.55+/-0.05mm 2. Review the Solderability temperature from 235±5℃ to 245±5.℃,Solderability time from 2 ±0.5s to 5±0.5s,	5,6,8 10
2013/10/18	7	Review the packing specification	11
2016/3/2	8	1. Review the Available lead code of Lead Configuration. 2. Delete the definition about “Old Part No.” 3. Delete 6pF~18pF (Code of diameter dimension is 060) , 22pF~27pF (Code of diameter dimension is 080), 30pF~39pF (Code of diameter dimension is 090) and 47pF (Code of diameter dimension is 110)for P/N CH 6KV. 4. Review 9. Drawing of internal structure and material list	5 5,6 6 15
2016/11/3	9	1. Delete “CH” series. 2. Delete 2pF~8pF (Code of diameter dimension is 060) for P/N SL 6KV.	4,6,7,9~11,14,15 6

Table of Contents

No.	Item	Page
1	Part number for SAP system	4/15
2	Mechanical	5/15
3	Capacitance value vs. Rate voltage, product diameter	6/15
4	Marking	7/15
5	Taping Format	8/15
6	Specification and test method	9/15~11/15
7	Packing specification	12/15
8	Notices	13/15~14/15
9	Drawing of internal structure and material list	15/15



1. Part number for SAP system :

SL 602 050 C 060 B 20 C 7 H
(1) (2) (3) (4) (5) (6) (7) (8) (9) (10)

- (1)Temperature Characteristic : SL:+350~-1000ppm/°C
- (2)Rate Voltage(identified by 3-figure code) : 602=6KVDC
- (3)Rate Capacitance (identified by code) : ex. 100=10pF, 101=100pF
- (4)Tolerance of Capacitance : J= ±5%(For above 10pF)
- (5)Nominal body diameter dimension (Ref. to page.6 Dφ Code spec.) .
- (6)Lead Style : Refer to “2. Mechanical”.
- (7)Packing mode and lead length (identified by 2-figure code) :

Taping Code	Description
AF	Box and Pitch : 15.0 mm
AM	Box and Pitch : 25.4 mm

Bulk Code	Description
3E	Lead length : 3.5mm
04	Lead length : 4.0mm
4E	Lead length : 4.5mm
20	Lead length : 20.0mm

- (8)Length tolerance :

Code	Description
A	±0.5 mm (only for kink lead type)
B	±1.0 mm
C	MIN.
D	Taping special purpose

- (9)Lead Pitch :

Code	Description
7	7.5±1 mm
0	10±1 mm

- (10) Epoxy Resin Code :

Code	Description
B	Pb free, Epoxy Resin
H	Halogen and Pb free , epoxy resin.

2. Mechanical:

Available lead code (Epoxy Resin Coating)- (unit: mm)

Lead type	SAP P/N (13-17)digits	Pitch (F)	Lead Length (L)	Packing	Lead Configuration
Lead style : B Straight long lead	B20C7	7.5 ± 1.0	20 MIN.	Bulk	
	B20C0	10 ± 1.0	20 MIN.		
	BAFD7	7.5 ± 1.0	Refer to "5. Taping format"	Tap. Ammo	
	BAMD0	10 ± 1.0			
Lead style : L Straight short lead	L03B7	7.5 ± 1.0	3.0 ± 1.0	Bulk	
	L4EB7	7.5 ± 1.0	4.5 ± 1.0		
	L05B7	7.5 ± 1.0	5.0 ± 1.0		
	L10B7	7.5 ± 1.0	10.0 ± 1.0		
	L03B0	10 ± 1.0	3.0 ± 1.0		
	L4EB0	10 ± 1.0	4.5 ± 1.0		
	L05B0	10 ± 1.0	5.0 ± 1.0		
L10B0	10 ± 1.0	10.0 ± 1.0			
Lead style : X Outside kink lead	X3EA7	7.5 ± 1.0	3.5 ± 0.5	Bulk	
	X04A7	7.5 ± 1.0	4.0 ± 0.5		
	X05B7	7.5 ± 1.0	5.0 ± 1.0		
	X3EA0	10 ± 1.0	3.5 ± 0.5		
	X04A0	10 ± 1.0	4.0 ± 0.5	Tap. Ammo	
	X05B0	10 ± 1.0	5.0 ± 1.0		
	XAFD7	7.5 ± 1.0	Refer to "5. Taping format"		
XAMD0	10 ± 1.0				
Lead style : D Vertical kink short lead	D3EA7	7.5 ± 1.0	3.5 ± 0.5	Bulk	
	D04A7	7.5 ± 1.0	4.0 ± 0.5		
	D3EA0	10 ± 1.0	3.5 ± 0.5		
	D04A0	10 ± 1.0	4.0 ± 0.5		
	DAFD7	7.5 ± 1.0	Refer to "5. Taping format"	Tap. Ammo	
DAMD0	10 ± 1.0				
Lead style : H Inside kink lead	H3EA0	10.0±1.0	3.5±0.5 mm	Bulk	

* Lead diameter Φd : 0.55+/-0.05mm

* **e** (Coating **extension** on leads): 3.0mmMax for straight lead lead style, not exceed the kink for kink lead.

※When $D\phi \geq 11$ mm, only for bulk, but $D\phi \leq 10$ mm can do Bulk or Taping.

6KV TEMPERATURE COMPENSATING CERAMIC CAPACITOR	POE-D03-00-E-09	Ver: 9 Page: 6 / 15
---	-----------------	------------------------

3. Capacitance value vs. Rate voltage, product diameter :

3.1 、 6KV:

Manufacturing product range Cap. Value vs. Rate voltage, product diameter & type		Photo	SL
T.C.	SL (CLASS I , Temperature:+20℃~+85℃, T.C.C.: +350 ~ -1000ppm)		
Rate voltage	6KV		
Dφ(Code)	060	080	090
D max. (mm)	7.5	9.5	10.5
T max. (mm)	5.0	5.0	5.0
2			
3			
5			
6			
7			
8			
10	100		
12	120		
15	150		
18	180		
20	200		
22	220		
27	270		
30	300	300	
33	330	330	
39	390	390	
47		470	470
51		510	510
56		560	560
62			
68			680
82			820
100			101
φd (mm)	0.55±0.05		
PACKING	TAPING or BULK		
COATING	Epoxy Resin		

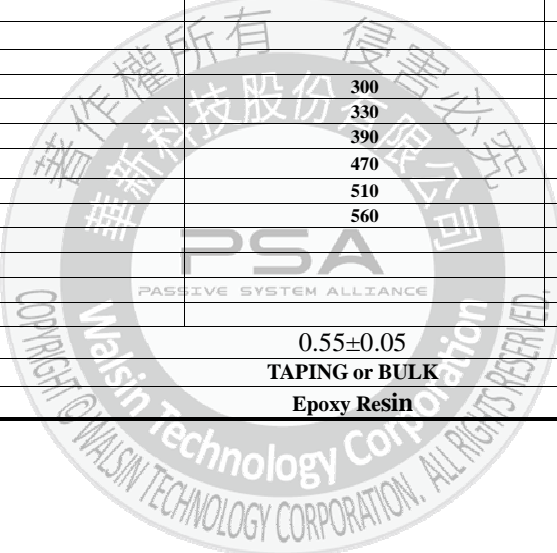

6KV TEMPERATURE COMPENSATING CERAMIC CAPACITOR	POE-D03-00-E-09	Ver: 9 Page: 7 /15
---	-----------------	-----------------------

4. Marking :

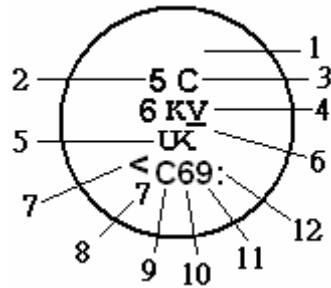

1. Temperature characteristic	2. Nominal capacitance	3. Capacitance tolerance	4. Rated voltage	5. Manufacturer's identification	6. Halogen and Pb free
SL : No marking	1. Identified by 3-figure code when Cap. ≥ 100pF Ex. 120pF → "121" 2. When Cap < 100pF, marked actual Cap. value Ex. 6pF → "6"	J: ±5% (For above 10pF)	6000V : Be marked "6kV"	Shall be marked as "UK", but when the code of body diameter dimension ≤ 060 shall be omitted.	When the epoxy resin is Halogen and Pb free, there is a " _ " marking.
Definition of date code marking:					
7. Supplier of Epoxy	8. No. of test equipment	9. Factory of manufacture	10. Year of manufacture	11. Month of manufacture	12. Week of manufacture by month
<: K-company , : P-company	1~9 : No. 1~No. 9, J : No. 10, K : No. 11, L : No. 12	C : Factory of POEGZ	1 : 2011, 2 : 2012, 3 : 2013, 4 : 2014, 5 : 2015, 6 : 2016, 7 : 2017, ...	1~9 : January~ September, O : October, N : November, D : December	week 1: - week 2: · week 3: : week 4: · week 5: ;

5. Taping Format:

- 15mm pitch/lead spacing 7.5mm taping

Lead Code: ***BAFD7** & ***DAFD7** & ***XAFD7**

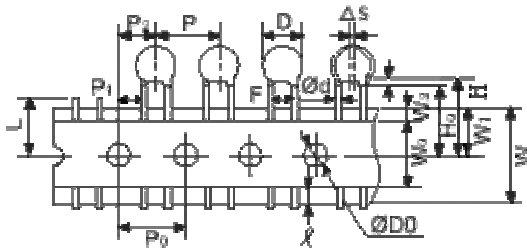

- 25.4mm pitch/lead spacing 10.0mm taping

Lead Code: ***DAMD0** & ***XAMD0** & ***BAMD0**

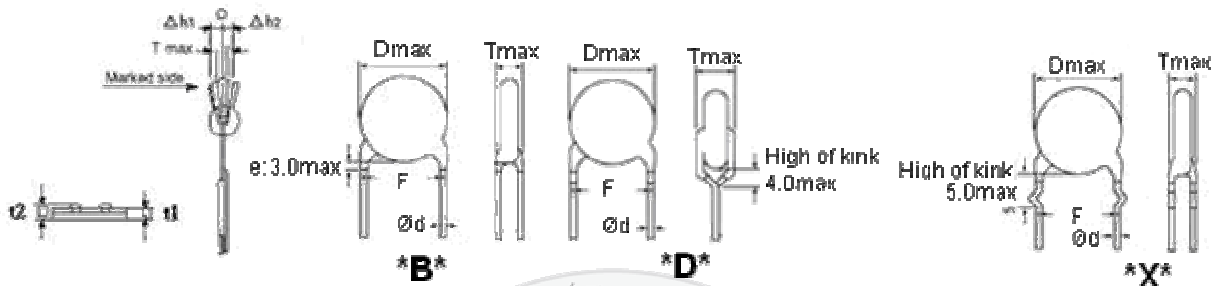
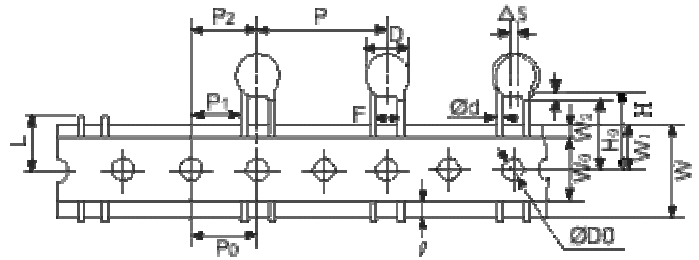

POE Part Number		*BAFD7	*DAFD7 *XAFD7	*BAMD0 *DAMD0 *XAMD0
Item	Symbol	Dimensions (mm)	Dimensions (mm)	Dimensions (mm)
Pitch of component	P	15.0	15.0	25.4
Pitch of sprocket	P0	15.0±0.3	15.0±0.3	12.7±0.3
Lead spacing	F	7.5±1.0	7.5±1.0	10.0±1.0
Length from hole center to component center	P2	7.5±1.5	7.5±1.5	12.7 ± 1.5
Length from hole center to lead	P1	3.75±1.0	3.75±1.0	7.7±1.5
Body diameter	D	See the "3. Capacitance value vs. Rate voltage, product diameter"		
Deviation along tape, left or right	ΔS	0±2.0		
Carrier tape width	W	18.0 +1/-0.5		
Position of sprocket hole	W1	9.0±0.5		
Lead distance between the kink and center of sprocket hole	H0	---	18.0+2.0/-0	18.0+2.0/-0 For: *DAMD0 *XAMD0
Lead distance between the bottom of body and the center of sprocket hole	H	20.0+1.5/-1.0	---	20.0+1.5/-1.0 For: *BAMD0
Protrusion length	ℓ	2.0max (Or the end of lead wire may be inside the tape.)		
Diameter of sprocket hole	D0	4.0±0.2		
Lead diameter	φd	0.55 ±0.05		
Total tape thickness	t1	0.6±0.3		
Total thickness, tape and lead wire	t2	1.5 max.		
Deviation across tape	Δh1	2.0 max.		
	Δh2	2.0 max.		
Portion to cut in case of defect	L	11.0 max.		
Hole-down tape width	W0	11.5min		
Hole-down tape distortion	W2	1.5±1.5		
Coating extension on leads	e	3.0 max for straight lead style; Not exceed the kink leads for kink lead.		
Body thickness	T	See the "3. Capacitance value vs. Rate voltage, product diameter"		

6. Specification and test method:

6.1 SCOPE: THIS SPECIFICATION APPLIES TO TEMPERATURE COMPENSATING CONSTANT, 3KV CERAMIC CAPACITOR.

6.2 TEST CONDITIONS:

UNLESS OTHERWISE SPECIFIED, ALL TESTS SHALL BE OPERATED AT THE STANDARD TEST CONDITIONS OF TEMPERATURE 5°C TO 35°C AND RELATIVE HUMIDITY 45% TO 85%. WHEN FAILS A TEST, RETEST BE OPERATED AT THE CONDITIONS OF TEMPERATURE 25°C ± 2°C, RELATIVE HUMIDITY OF 60% TO 70% AND BAROMETRIC PRESSURE 860 TO 1060 MBAR.

6.3 HANDLE PROCEDURE: TO AVOID UNEXPECT TESTING RESULTS FROM OCCURING, THE TESTED CAPACITOR MUST BE KEPT AT ROOM TEMPERATURE FOR AT LEAST 30 MINUTES AND COMPLETELY DISCHARGED.

6.4 TEST ITEMS:

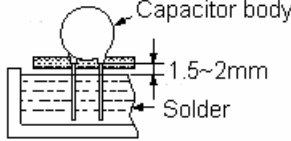

ITEM	POST-TEST REQUIREMENTS	TESTING PROCEDURE
APPEARANCE STRUCTURE SIZE	NO ABNORMALITIES	AS STATED IN SECTION 3.1 & 3.2
MARKING		AS STATED IN SECTION 4
WITHSTAND VOLTAGEN	BETWEEN TERMINALS: NO ABNORMALITIES	RATED VOLTAGE 6KVDC: 150% OF THE RATED VOLTAGE FOR 1 TO 5 SECONDS.(TEST VOLTAGE : 9000VDC, 1~5 SEC), WITH 50mA MAX. CHARGING CURRENT
	BETWEEN TERMINAL AND ENCLOSURE : NO ABNORMALITIES	SMALL METALLIC BALLS WITH 1mm DIAMETERS SHALL BE PUT ON A VESSEL AND THE TEST CAPACITOR SHALL BE SUBMERGED EXCEPT 2mm FROM THE TOP OF ITS COMPONENT BODY. THE TEST VOLTAGE SHALL BE APPLIED BETWEEN THE SHORT-CIRCUIED TERMINALS AND THE METALLIC BALLS. (APPLY 1.3KV DC OF RATED VOLTAGE BETWEEN TERMINALS AND ENCLOSURE FOR 1~5 SEC)
INSULATION RESISTANCE	10000 MΩ MIN	INSULATION RESISTANCE SHALL BE MEASURED AT 60±5 SECONDS AFTER RATED VOLTAGE APPLIED. RATED VOLTAGE : 500VDC
CAPACITANCE	TOLERANCE : J : ±5% , K : ±10%	TESTING FREQUENCY: 1MHZ ± 20 % TESTING TEMPERATURE: 25 ± 2°C TESTING VOLTAGE: 1.0 ± 0.2 VRMS
OPERATING TEMPERATURE RANGE	WIDE OPERATING TEMPERATURE RANGE : -25°C TO +125°C (INCLUDING MAXIMUM TEMPERATURE RISE OF +20°C)	
Q FACTOR)	30PF&Above	AS ABOVE STIPULATION OF CAPACITANCE
	Below 30PF	
	≥ 1000	≥ 400+20×
TEMPERATURE CHARACTERISTIC	Temperature coefficient: SL: +350 ~ -1000ppm/°C (+20°C ~+85°C) CAPACITANCE TOLERANCE: SL WITHIN ±0.2% OR ±0.05PF, WHICHEVER IS LARGE	ACCORDING TO STEP 1 TO 5 IN ORDER, MEASURED CAPACITANCE WHEN TEMPERATURE REACH BALANCE AND TEMPERATURE COEFFICIENT SHALL BE CALCULATED ON THE FOLLOWING FORMULA : PPM/°C =(C2-C1)×10E6/C1(T2-T1) STEP 1,3,5: 25°C STEP 4: 85°C STEP 2: -25°C , SL(+20°C) NOTE : C1 = CAPACITANCE AS STEP 3 C2 = CAPACITANCE AS STEP 2 OR 4 T1 = TEMPERATURE AS STEP 3 T2 = TEMPERATURE AS STEP 2 OR 4 ACCORDING TO ABOVE STEP 1,3 & 5, CAPACITANCE TOLERANCE SHALL BE CALCULATED ON THE FOLLOWING FORMULA : △ C % =(G - S)/C1 NOTE: G = GREATEST CAPACITANCE AS TESTING RESULT OF STEP 1,3 & 5 S = LEAST CAPACITANCE AS TESTING RESULT OF STEP 1,3 & 5 C1 = CAPACITANCE AS STEP 3

ITEM	POST-TEST REQUIREMENTS	TESTING PROCEDURE
TERMINAL STRENGTH	TENSIBLE STRENGTH: NO BREAKDOWN	WIRE DIA.0.6mm, LOADING WEIGHT 1.0KG FOR 10±1 SECONDS
	BENDING STRENGTH: NO BREAKDOWN	WIRE DIA.0.6mm, LOADING WEIGHT 0.5 KG. (BENDING BACK AND FORTH 90 DEGREE TWICE)
SOLDERING HEAT RESISTANCE	APPEARANCE: NO ABNORMALITIES	<p>AS SHOWN IN FIGURE, THE LEAD WIRES SHOULD BE IMMERSSED IN THE MOLTEN SOLDER UP TO 1.5 TO 2.0mm FROM THE ROOT OF TERMINAL.</p>  <p>(A) BODY DIA. ≤ 6.3mm: INTO THE MOLTEN SOLDER OF WHICH TEMPERATURE: 270±5°C FOR 3±0.5 SECONDS.</p> <p>(B) BODY DIA. > 6.3mm: INTO THE MOLTEN SOLDER OF WHICH TEMPERATURE 350±10°C FOR 3±0.5 SECONDS THEN LEAVE AT STANDARD TEST CONDITIONS FOR 24±2 HOURS, THEN MEASURED.</p>
	CAP.CHANGE: SL WITHIN ±2.5% OR ±0.25PF, WHICHEVER IS LARGE.	
	WITHSTAND VOLTAGE: (BETWEEN TERMINALS) NO ABNORMALITIES	
SOLDERABILITY	LEAD WIRE SHALL BE SOLDERED OVER 75% OF THE CIRCUMFERENTIAL DIRECTION.	TO COMPLY WITH JIS-C-5102 8.4 SOLDER TEMPERATURE 245±5°C AND DIPPING TIME 5±0.5 SECONDS FLUX : WEIGHT RATIO OF POSIN 25%
HUMIDITY CHARACTERISTIC (STABLE SITUATION)	APPEARANCE: NO ABNORMALITIES	CAPACITORS SHALL BE SUBJECTED TO A RELATIVE HUMIDITY OF 90 ~ 95% AT 40±2°C FOR 500(+24/-0) HOURS. THEN DRIED FOR 1~2 HOURS AND MEASURED.
	CAP.CHANGE: SL WITHIN ±5% OR ±0.5PF, WHICHEVER IS LARGE.	
	Q FACTOR: SL LESS THAN 10PF => Q ≥ 200 + 10 × C MORE THAN 10PF AND LESS THAN 30PF => Q ≥ 275 +5 × C/2 MORE THAN 30PF => Q ≥ 350	
	INSULATION RESISTANCE: 1000MΩ MIN.	

ITEM	POST-TEST REQUIREMENTS	TESTING PROCEDURE
<p>HUMIDITY LOADING</p>	<p>APPEARANCE: NO ABNORAMLITIES</p>	<p>CAPACITORS SHALL BE SUBJECTED TO A RELATIVE HUMIDITY OF 90 ~ 95% AT 40 ± 2°C FOR 500(+24/-0) HOURS WITH RATED VOLTAGE APPLIED WITH 50mA MAX. THEN DRIED FOR 1~2 HOURS AND MEASURED.</p>
	<p>CAP.CHANGE: SL WITHIN ±7.5 % OR ±0.75PF, WHICHEVER IS LARGE.</p>	
	<p>Q FACTOR: SL LESS THAN 30PF => Q ≥ 100 +10 × C/3 MORE THAN 30PF => Q ≥ 200</p>	
	<p>INSULATION RESISTANCE: 500 MΩ MIN</p>	
<p>HIGH TEMPERATURE LOADING</p>	<p>APPEARANCE : NO ABNORMALITIES</p>	<p>150% RATED VOLTAGE WITH 50mA max. FOR 1000(+48/-0) HOURS AT 125±2°C AND THEN DRIED FOR 1~2 HOURS AND MEASURED.</p>
	<p>CAP.CHANGE : WITHIN ±3 % OR ±0.3PF, WHICHEVER IS LARGE.</p>	
	<p>Q FACTOR: SL: LESS THAN 10PF => Q ≥ 200 + 10 × C MORE THAN 10PF AND LESS THAN 30PF =>Q ≥ 275 +5 × C/2 MORE THAN 30PF => Q ≥ 350</p>	
	<p>INSULATION RESISTANCE: 1000 MΩ MIN.</p>	

7.Packing Baggage :

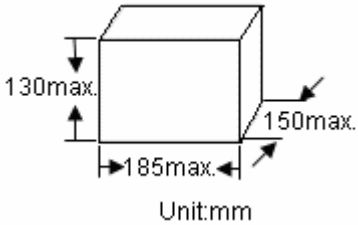
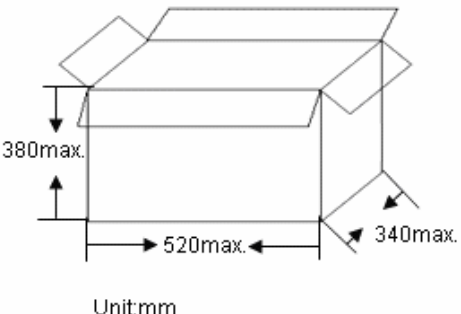
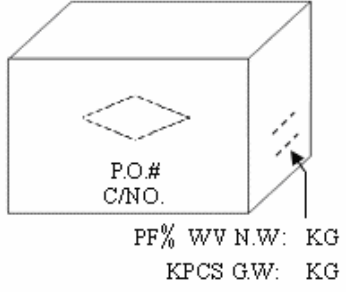
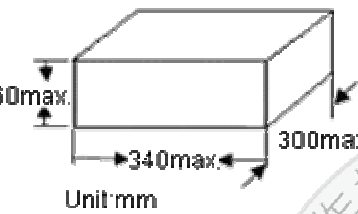
7.1 Packing size:

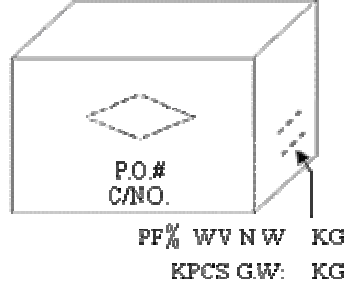
Type	Box	Carton	
Bulk	 <p>Unit:mm</p>	 <p>Unit:mm</p>	 <p>P.O.# C/NO. PF% WV N.W.: KG KPCS G.W.: KG</p>
Ammo taping	 <p>Unit:mm</p>	 <p>Unit:mm</p>	 <p>P.O.# C/NO. PF% WV N.W.: KG KPCS G.W.: KG</p>

7.2 Packing quantity:

Packing type	The code of 14th to15th in SAP P/N	MPQ (Kpcs/ Box)
Taping	AF	1
	AM	0.5

Packing type	MPQ (Kpcs/Bag)
Bulk	1

8. Notices:

8.1 Operating Voltage:

When DC-rated capacitors are to be used in AC or ripple current circuits, be sure to maintain the V_{p-p} value of the applied voltage or the V_{0-p} which contains DC bias within the rated voltage range.

When the voltage is applied to the circuit, starting or stopping may generate irregular voltage for a transit period because of resonance or switching. Be sure to use a capacitor with a rated voltage range that includes these irregular voltages.

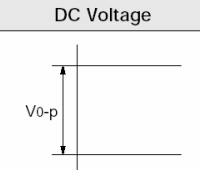
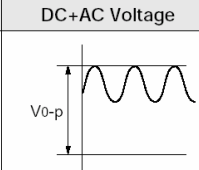
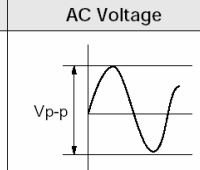
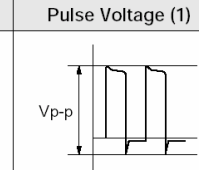
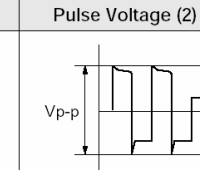
Voltage	DC Voltage	DC+AC Voltage	AC Voltage	Pulse Voltage (1)	Pulse Voltage (2)
Positional measurement					

8.2 Operating Temperature and Self-generated Heat

Keep the surface temperature of a capacitor below the upper limit of its rated operating temperature range. Be sure to take into account the heat generated by the capacitor itself. When the capacitor is used in a high frequency current, pulse current or similar current, it may self-generate heat due to dielectric loss. The frequency of the applied sine wave voltage should be less than 100kHz. The applied voltage load (*) should be such that the capacitor's self-generated heat is within 20°C at an atmosphere temperature of 25°C. When measuring, use a thermocouple of small thermal capacity-K of $\phi 0.1\text{mm}$ in conditions where the capacitor is not affected by radiant heat from other components or surrounding ambient fluctuations.

Excessive heat may lead to deterioration of the capacitor's characteristics and reliability. (Never attempt to perform measurement with the cooling fan running. Otherwise, accurate measurement cannot be ensured.)

8.3 Fail-Safe

When capacitor is broken, failure may result in a short circuit. Be sure to provide an appropriate fail-safe function like a fuse on your product if failure would follow an electric shock, fire or fume.

8.4 Operating and storage environment

The insulating coating of capacitors does not form a perfect seal; therefore, do not use or store capacitors in a corrosive atmosphere, especially where chloride gas, sulfide gas, acid, alkali, salt or the like are present. And avoid exposure to moisture. Before cleaning, bonding or molding this product, verify that these processes do not affect product quality by testing the performance of a cleaned, bonded or molded product in the intended equipment. Store the capacitors where the temperature and relative humidity do not exceed -10 to 40 degrees centigrade and 15 to 85 % for 6 months maximum and use within the period after receiving the capacitors.

FAILURE TO FOLLOW THE ABOVE CAUTIONS MAY RESULT, WORST CASE, IN A SHORT CIRCUIT AND CAUSE FUMING OR PARTIAL DISPERSION WHEN THE PRODUCT IS USED.

8.5 Vibration and impact

Do not expose a capacitor or its leads to excessive shock or vibration during use.

8.6 Soldering

When soldering this product to a PCB/PWB, do not exceed the solder heat resistance specification of the capacitor. Subjecting this product to excessive heating could melt the internal junction solder and may result in thermal shocks that can crack the ceramic element. When soldering capacitor with a soldering iron, it should be performed in following conditions.

Temperature of iron-tip: 400 degrees C. max.

Soldering iron wattage : 50W max.

Soldering time : 3.5 sec. max.

FAILURE TO FOLLOW THE ABOVE CAUTIONS MAY RESULT, WORST CASE, IN A SHORT CIRCUIT AND CAUSE FUMING OR PARTIAL DISPERSION WHEN THE PRODUCT IS USED.

8.7 Cleaning (ultrasonic cleaning)

To perform ultrasonic cleaning, observe the following conditions.

Rinse bath capacity : Output of 20 watts per liter or less.

Rinsing time : 5 min. maximum.

Do not vibrate the PCB/PWB directly.

Excessive ultrasonic cleaning may lead to fatigue destruction of the lead wires.

8.8 Rating

Capacitance change of capacitor

I. Class 1 series (Temp. Char. SL)

Capacitance might change a little depending on the surrounding temperature or an applied voltage.

Please contact us if you intend to use this product in a strict time constant circuit.

9.Drawing of internal structure and material list:

產品結構圖

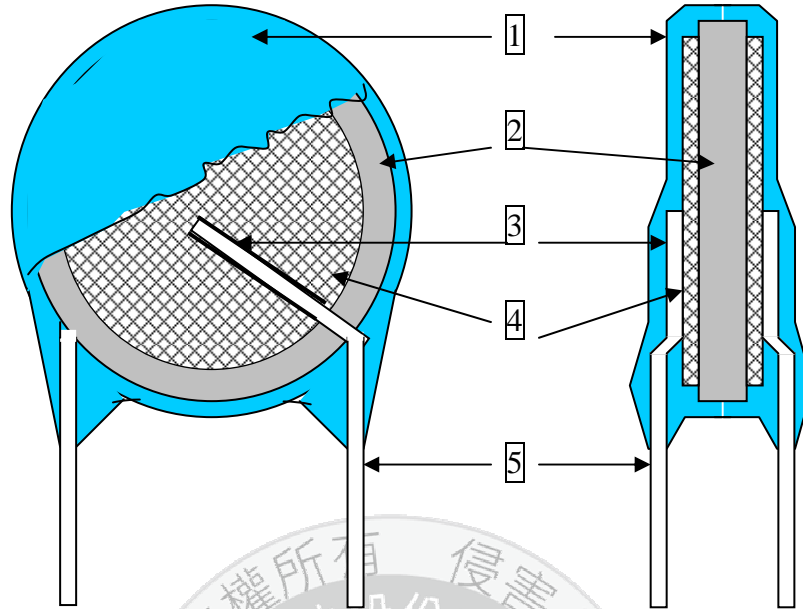

Remarks :

No.	Part name	Material	Model/Type	Component
1	Insulation Coating	Epoxy polymer	1.EE-150C 2.EF-150(HF) 3.PCE-210 2.PCE-300(HF)	Epoxy resin、Pigment (Blue / UL 94 V-0 /) The minimum thickness of coating (reinforced insulation) is 0.4mm
2	Dielectric Element	Ceramic	SL	BaTiO ₃
3	Solder	Tin-silver	Sn96.5-Ag3-Cu0.5	Sn96.5-Ag3-Cu0.5
4	Electrodes	Ag	1.SP-160PL 2.SP-260PL	Silver、Glass frit
5	Leads wire	Tinned copper clad steel wire	0.55±0.05 mm	Substrate metal: Fe & Cu Surface plating: Sn 100%(3~7μm)

X-ON Electronics

Largest Supplier of Electrical and Electronic Components

Click to view similar products for [Ceramic Disc Capacitors](#) category:

Click to view products by [Walsin](#) manufacturer:

Other Similar products are found below :

[5AU100JCECA](#) [5AU220JCGCA](#) [5AU560JCJCA](#) [DEF2CLH020CA3B](#) [DEF2CLH030CJ3B](#) [NCD102K1KVY5FF](#) [NCD101K1KVY5FF](#)
[NCD103M1KVZ5UF](#) [NCD331K1KVY5FF](#) [440LT68AP-R](#) [CK60AX471M](#) [NCD103M1KVZ5UJTBF](#) [DEF2CLH040CN3A](#)
[DEF2CLH080DA3B](#) [564R3DF0T22](#) [0811-040-X7R0-102K](#) [8903D0](#) [90410-10](#) [0838-040-X7R0-220K](#) [YV101103Z060HAND5P](#)
[SL102101J060BAND5P](#) [YP202102K080D04A7H](#) [ZU501103M090B20C6P](#) [ZU102103M100X05B0P](#) [YP102271K050B20C6P](#)
[YP102391K050BAND5P](#) [YP501101K040BAND5P](#) [YP102681K060B20C6P](#) [YP501121K040B20C6P](#) [SL102181J070HAND5P](#)
[YP501471K040B20C6P](#) [SL102151J070HAND5P](#) [YP501102K050HAND5P](#) [ZU501102M050B20C6P](#) [ZU102103M100B20C0P](#)
[YV500223Z080HAND5P](#) [F121K25S3NN63J5R](#) [F121K25S3NP63K7R](#) [F121K25S3NR63K7R](#) [F122K47S3NP63K7R](#) [F151K29S3NR63K7R](#)
[F681K43S3NR63K7R](#) [HVCC103Y6P152MEAX](#) [F681K29S3NN63J5R](#) [S103Z43Y5VN6TJ5R](#) [DCH102K34Y5PP6FJ5A0](#)
[CC2A104ZC1ED3F7C1100](#) [CC1H103ZA1ED3F4D1100](#) [CC3A222MC1GEF45H31MF](#) [CC1H151KC1EDB44B1100](#)