

# APPROVAL SHEET

## **WR02X(W)**

**±5%, ±1%**

Thick Film General purpose chip resistors

Size 0201

RoHS 2 Compliant with exemption 7C-1

Halogen free

---

\*Contents in this sheet are subject to change without prior notice.

## FEATURE

1. Small size and light weight
2. High reliability and stability
3. Reduced size of final equipment
4. Suitable for high density print circuit board assembly
5. Higher component and equipment reliability
6. RoHS 2 Compliant with exemption 7C-1 Halogen free

## APPLICATION

- Mobile phone
- PDA
- Camcorders
- Palmtop computers
- Hybrid module

## DESCRIPTION

The resistors are constructed in a high grade ceramic body (aluminum oxide). Internal metal electrodes are added at each end and connected by a resistive paste that is applied to the top surface of the substrate. The composition of the paste is adjusted to give the approximate resistance required and the value is trimmed to nominated value within tolerance which controlled by laser trimming of this resistive layer.

The resistive layer is covered with a protective coat. Finally, the two external end terminations are added. For ease of soldering the outer layer of these end terminations is a pure Tin.

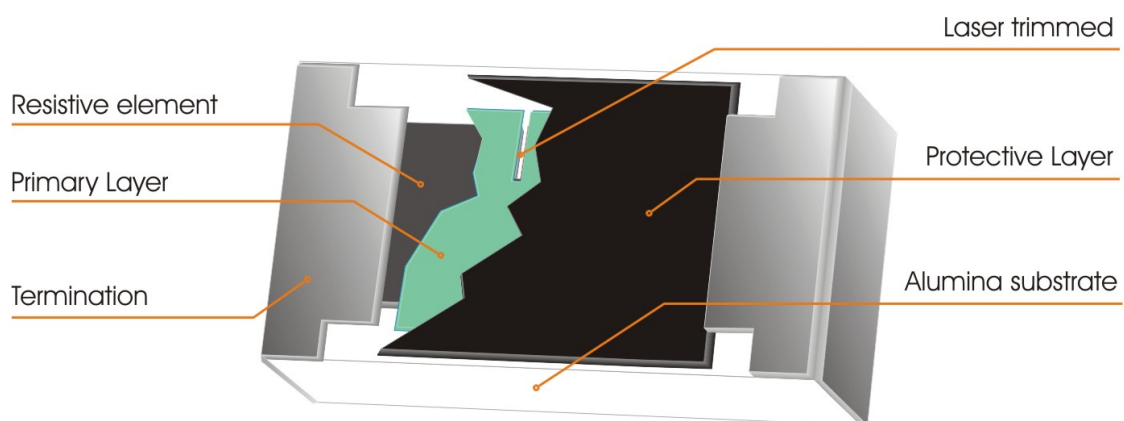

Fig 1. Construction of Chip-R WR02X

**QUICK REFERENCE DATA**

Item	General Specification	
Series No.	WR02X(W)	
Size code	0201(0603)	
Resistance Range	1Ω~10MΩ ( ±5% tolerance ), Jumper 1Ω~ 10MΩ ( ±1% tolerance )	
Resistance Tolerance	±1% E96/E24	±5% E24
TCR (ppm/°C)	10Ω - 10MΩ, ≤±200 1 - 9.76Ω, +600~-200	
Max. dissipation @ T <sub>amb</sub> =70°C	1/20 W	
Max. Operation Voltage (DC or RMS)	25V	
Max. Overload Voltage (DC or RMS)	50V	
Operation temperature	-55 ~ +125°C	

Note :

- This is the maximum voltage that may be continuously supplied to the resistor element, see "IEC publication 60115-8"
- Max. Operation Voltage : So called RCWV (Rated Continuous Working Voltage) is determined by

$$RCWV = \sqrt{\text{Rated Power} \times \text{Resistance Value}} \text{ or Max. RCWV listed above, whichever is lower.}$$

**DIMENSION(unit : mm)**

	WR02X(W)
<b>L</b>	0.60 ± 0.03
<b>W</b>	0.30 ± 0.03
<b>T</b>	0.23 ± 0.03
<b>Tb</b>	0.15 ± 0.05
<b>Tt</b>	0.10 ± 0.05

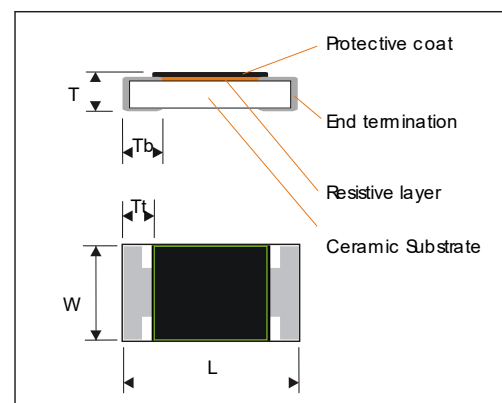
**MARKING**

WR02X(W) has no marking.

## FUNCTIONAL DESCRIPTION

### Product characterization

Standard values of nominal resistance are taken from the E24/E96 series for resistors with a tolerance of  $\pm 5\%$  &  $\pm 1\%$ . The values of the E24/E96 series are in accordance with "IEC publication 60063"

### Derating

The power that the resistor can dissipate depends on the operating temperature; see Fig.2

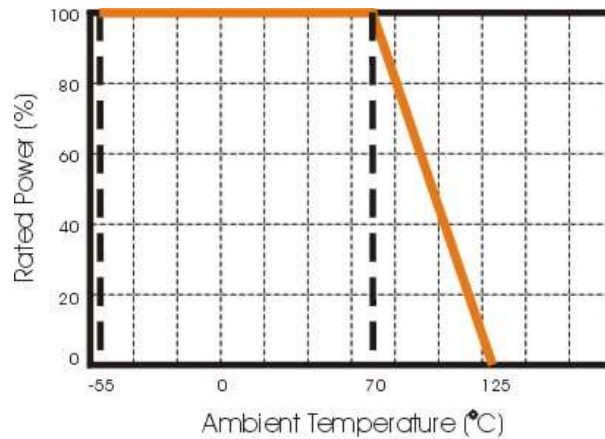

Figure 2. Maximum dissipation in percentage of rated power  
As a function of the ambient temperature

## MOUNTING

Due to their rectangular shapes and small tolerances, Surface Mountable Resistors are suitable for handling by automatic placement systems.

Chip placement can be on ceramic substrates and printed-circuit boards (PCBs).

Electrical connection to the circuit is by individual soldering condition.

The end terminations guarantee a reliable contact.

## SOLDERING CONDITION

The robust construction of chip resistors allows them to be completely immersed in a solder bath of 260°C for 10 seconds. Therefore, it is possible to mount Surface Mount Resistors on one side of a PCB and other discrete components on the reverse (mixed PCBs).

Surface Mount Resistors are tested for solderability at 235°C during 2 seconds. The test condition for no leaching is 260°C for 30 seconds. Typical examples of soldering processes that provide reliable joints without any damage are given in Fig 3.

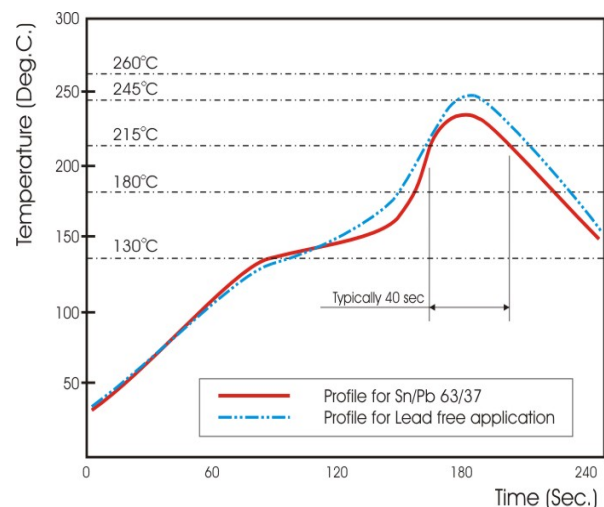

Fig 3. Infrared soldering profile for Chip Resistors WR02X(W)

## CATALOGUE NUMBERS

The resistors have a catalogue number starting with :

WR02	X	472_	J	A	L
<b>Size code</b> WR02 : 0201	<b>Type code</b> X : Normal W : 1% For <10Ω and >1MΩ	<b>Resistance code</b> 5%, E24: 2 significant digits followed by no. of zeros and a blank 4.7Ω = 4R7_ 100Ω = 101_ 10KΩ = 103_ 1%, E24+E96: 3 significant digits followed by no. of zeros 100Ω = 1000 37.4KΩ = 3742	<b>Tolerance</b> J : ±5% F : ±1% P : Jumper	<b>Packaging code</b> A : 7" Reeled taping (15Kpcs/Reel) T : 7" Reeled taping (10Kpcs/Reel) D : 7" Reeled taping (20Kpcs/Reel) H : 13" Reeled taping (50Kpcs/Reel) G : 13" Reeled taping (70Kpcs/Reel)	<b>Termination code</b> L = Sn base (lead free)

## TEST CONDITION FOR JUMPER (0 Ω)

Item	WR02
Power Rating At 70°C	1/20W
Resistance	MAX.50mΩ
Rated Current	1A
Peak Current within 5 sec	2.5A
Operating Temperature	-55 ~ +125°C

**TEST AND REQUIREMENTS (JIS C 5201-1 : 1998)**

TEST	PROCEDURE / TEST METHOD	REQUIREMENT	
		Resistor	Ω
Electrical Characteristics JISC5201-1: 1998 Clause 4.8	- DC resistance values measurement - Temperature Coefficient of Resistance (T.C.R) Natural resistance change per change in degree centigrade. $\frac{R_2 - R_1}{R_1(t_2 - t_1)} \times 10^6 \text{ (ppm/}^\circ\text{C)}$ $t_1 : 20^\circ\text{C}+5^\circ\text{C}-1^\circ\text{C}$ $R_1$ : Resistance at reference temperature ( $20^\circ\text{C}+5^\circ\text{C}/-1^\circ\text{C}$ ) $R_2$ : Resistance at test temperature ( $-55^\circ\text{C}$ or $+125^\circ\text{C}$ )	Within the specified tolerance Refer to "QUICK REFERENCE DATA"	<50mΩ
Short time overload (S.T.O.L) <b>Clause 4.13</b>	Permanent resistance change after a 5second application of a voltage 2.5 times RCWV or the maximum overload voltage specified in the above list, whichever is less.	$\Delta R/R$ max. $\pm(2\%+0.10\Omega)$	<50mΩ
Resistance to soldering heat(R.S.H) <b>Clause 4.18</b>	Un-mounted chips completely immersed for $10\pm 1$ second in a SAC solder bath at $260^\circ\text{C}\pm 5^\circ\text{C}$	$\Delta R/R$ max. $\pm(1\%+0.05\Omega)$ no visible damage	<50mΩ
Solderability <b>Clause 4.17</b>	Un-mounted chips completely immersed for $2\pm 0.8$ second in a SAC solder bath at $235^\circ\text{C}\pm 5^\circ\text{C}$	95% coverage min., good tinning and no visible damage	
Temperature cycling <b>Clause 4.19</b>	30 minutes at $-55^\circ\text{C}\pm 3^\circ\text{C}$ , 2~3 minutes at $20^\circ\text{C}+5^\circ\text{C}-1^\circ\text{C}$ , 30 minutes at $+125^\circ\text{C}\pm 3^\circ\text{C}$ , 2~3 minutes at $20^\circ\text{C}+5^\circ\text{C}-1^\circ\text{C}$ , total 5 continuous cycles	$\Delta R/R$ max. $\pm(1\%+0.05\Omega)$	< 50mΩ
Damp Heat (Load life in humidity) <b>Clause 4.24</b>	1000 +48/-0 hours, loaded with RCWV or $V_{\max}$ in humidity chamber controller at $40^\circ\text{C}\pm 2^\circ\text{C}$ and 90~95% relative humidity, 1.5hours on and 0.5 hours off	$10\Omega \leq R < 1\text{M}\Omega$ : $\Delta R/R$ max. $\pm(3\%+0.10\Omega)$ $R < 10\Omega$ , $R \geq 1\text{M}\Omega$ : $\Delta R/R$ max. $\pm(5\%+0.10\Omega)$	< 50mΩ
Load Life (Endurance) <b>Clause 4.25</b>	1000+48/-0 hours; loaded with RCWV or $V_{\max}$ in chamber controller $70\pm 2^\circ\text{C}$ , 1.5 hours on and 0.5 hours off	Ditto.	
Bending strength <b>Clause 4.33</b>	Resistors mounted on a 90mm glass epoxy resin PCB(FR4), bending once 5mm for 10sec.	No visual damaged, $\Delta R/R$ max. $\pm(1\%+0.05\Omega)$	< 50mΩ
Adhesion <b>Clause 4.32</b>	Pressurizing force: 3N, Test time: $10\pm 1$ sec.	No remarkable damage or removal of the terminations	

**PACKAGING**

Paper Tape specifications (unit :mm)

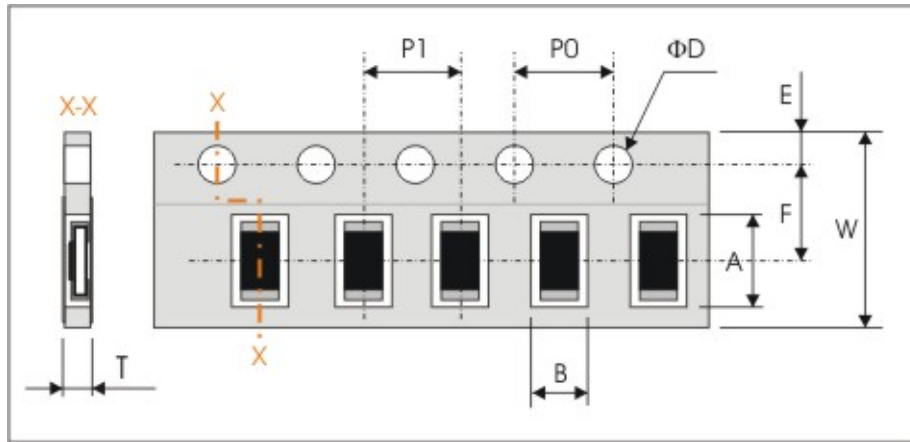

Series No.	A	B	W	F	E
WR02X	0.67±0.05	0.37±0.05	8.00±0.20	3.50±0.05	1.75±0.10

Series No.	P1	P0	ΦD	T
WR02X	2.00±0.05	4.00±0.05	Φ1.50 <sup>+0.1</sup> <sub>-0.0</sub>	0.45±0.05

**Reel dimensions**

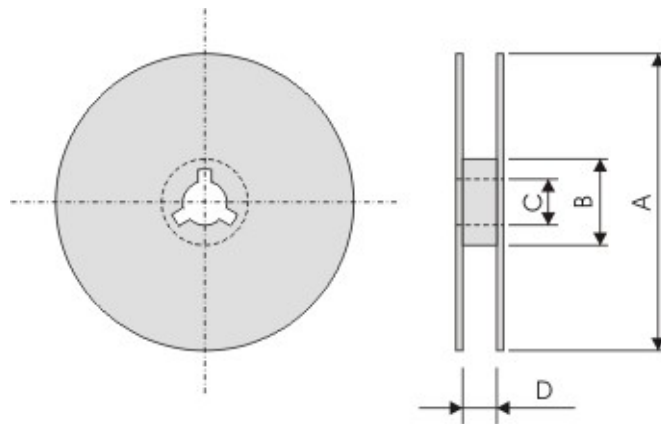

Symbol	A	B	C	D
7" Reel	Φ178.0±0.2	Φ60.0±1.0	13.0±0.2	9.0±0.5
10" Reel	Φ254.0±2.0	Φ100.0±1.0	13.0±0.2	9.0±0.5
13" Reel	Φ330.0±2.0	Φ100.0±1.0	13.0±0.2	9.0±0.5

**Taping quantity and Tape material**

- Chip resistors 10,000 / 15,000 / 20,000 pcs 7" Reel, Paper tape.
- Chip resistors 50,000 / 70,000 pcs 13" Reel, Paper tape.

## X-ON Electronics

Largest Supplier of Electrical and Electronic Components

*Click to view similar products for [Thick Film Resistors - SMD category](#):*

*Click to view products by [Walsin manufacturer](#):*

Other Similar products are found below :

[CR-05FL7--150R](#) [CR-05FL7--698K](#) [CR-12FP4--324R](#) [CR-12JP4--680R](#) [CRCW04021K20FKEE](#) [CRCW06032K10FKEC](#)  
[CRCW06036K80FKEE](#) [M55342K03B499DRS6](#) [M55342K06B6E19RWL](#) [M55342M06B26E7RS3](#) [742C083750JTR](#) [MCR01MZPF1202](#)  
[MCR01MZPF1601](#) [MCR01MZPF1800](#) [MCR01MZPF6201](#) [MCR01MZPF9102](#) [MCR01MZPJ121](#) [MCR01MZPJ125](#) [MCR01MZPJ751](#)  
[MCR03EZHJ103](#) [MCR03EZPF2004](#) [MCR03EZPJ270](#) [MCR03EZPJ821](#) [MCR10EZPF1102](#) [MCR10EZPF2700](#) [MCR18EZPJ330](#)  
[RC1005F1152CS](#) [RC1005F1372CS](#) [RC1005F1912CS](#) [RC1005F2052CS](#) [RC1005F3011CS](#) [RC1005F471CS](#) [RC1005F4751CS](#)  
[RC1005F5621CS](#) [RC1005F6041CS](#) [RC1005J106CS](#) [RC1005J121CS](#) [RC1005J122CS](#) [RC1005J154CS](#) [RC1005J180CS](#) [RC1005J181CS](#)  
[RC1005J202CS](#) [RC1005J391CS](#) [RC1005J512CS](#) [RC1005J560CS](#) [RC1005J683CS](#) [RC1005J823CS](#) [RC1608F1022CS](#) [RC1608F333CS](#)  
[RC1608F3651CS](#)