



VL53L0X Distance Sensor

用户手册

产品概述

我是基于 VL53L0X 设计的飞行时间(ToF)测距模块，精确测距范围可达 2 米，I2C 接口通信，低功耗。

VL53L0X 是 ST 推出的第二代 FlightSense 技术的飞行时间传感器，与传统的测距传感器不同，VL53L0X 采用 ST 的 ToF 技术，无论目标颜色和反射率如何，都可以进行距离测量，抗干扰能力更强。

特点

- 支持 I2C 接口通信，可通过 IO 口控制模块开关
- 板载电平转换电路，可兼容 3.3V/5V 的工作电平
- 提供完善的配套资料手册(Raspberry/Arduino/STM32 示例程序和用户手册等)

产品参数

工作电压：3.3V/5V

产品尺寸：20mm × 24mm

通孔尺寸：2.0mm

测距范围：30 ~ 2000mm

测距精度：±5% (高速模式)，±3% (高精度模式)

测距时间(min)：20ms (高速模式)，200ms(高精度模式)

测距角度：25°

激光波长：940nm

工作温度：-20 ~ 70° C

接口说明

VCC : 电源正 (3.3V/5V 电源输入)

GND : 电源地

SDA : I2C 的数据引脚

SCL : I2C 的时钟引脚

SHUT : 引脚, 可接 IO 口

INT : 中断输出引脚, 可接 IO 口

硬件说明

VL53L0X

VL53L0X 飞行时间测距传感器是 ST 第二代激光测距模块, 采用市场尺寸最小的一种封装。VL53L0X 是完全集成的传感器, 配有嵌入式红外、人眼安全激光, 先进的滤波器和超高速光子探测阵列。VL53L0X 增强了 ST FlightSense™ 系列, 测量距离更长, 速度和精度更高, 从而开启了新应用之门。

即使在恶劣工作条件下, 该传感器也可以直接确定与目标物体之间的距离, 最远 2 米, 不受目标反射率影响。VL53L0X 非常适合用于无线和物联网, 采用超低功耗系统架构设计。

主要特征:

- 完全集成的微型模块
 - 940nm 激光 VCSEL
 - VCSEL 驱动器
 - 测距传感器, 配有先进的嵌入式微控制器
 - 4.4mmx2.4mmx1.0mm
- 与 VL53L1X FlightSense™ 测距传感器引脚兼容
- 快速准确的距离测距
 - 测量绝对距离达 2m
 - 报告的距离不受目标反射率影响
 - 在高红外环境光等级下运行
 - 先进的嵌入式光学串扰补偿, 以简化玻璃罩
- 人眼安全
 - 1 类激光设备, 符合最新标准 IEC 60825-1:2014, 第 3 版
- 易于集成
 - 可回焊单元件
 - 无需额外光学器件
 - 单电源
 - I2C 接口, 用于器件控制和数据传输
 - Xshutdown (复位) 和中断 GPIO

图片:

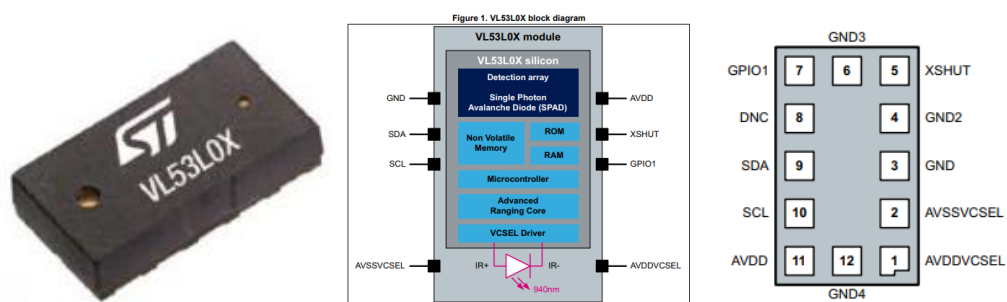

更多详细请参考数据手册:

用于树莓派

下文演示例程基于 [github](https://github.com/cassou/VL53L0X_rasp) 上的开源项目(https://github.com/cassou/VL53L0X_rasp)

硬件连接

以下为树莓派 BCM 管脚编码硬件连线（树莓派三代 B+）:

VL53L0X Distance Sensor	Raspberry Pi
VCC	3.3V
GND	GND
SDA	SDA.1
SCL	SCL.1

编译运行

示例程序复制到树莓派相应的路径上，进入到该路径底下，

输入：`sudo make clean && sudo make && sudo make examples`

编译完成后，进入到 `bin` 目录下，查看文件，具体如下：

```

Raspberry Pi 3 Model B+ - pi@raspberrypi: ~/VL53L0X/bin - Xshell 5 (Free for Home/School)
文件(F) 编辑(E) 查看(V) 工具(T) 选项卡(B) 窗口(W) 帮助(H)
ssh://pi:*****@192.168.1.198:22
要添加当前会话，点击左侧的箭头按钮。
1 Raspberry Pi 3 Model B+
pi@raspberrypi:~/VL53L0X $ cd ..
pi@raspberrypi:~ $ cd VL53L0X/
pi@raspberrypi:~/VL53L0X $ sudo make clean
rm -rf ./bin/* ./obj/*
pi@raspberrypi:~/VL53L0X $ clear
pi@raspberrypi:~/VL53L0X $ sudo make && sudo make examples
mkdir -p obj/
gcc -O0 -g -Wall -c -I. -I./Api/core/inc -I./platform/inc ./Api/core/src/vl53l0x_api_calibration.c -o obj/vl53l0x_api_calibration.o
mkdir -p obj/
gcc -O0 -g -Wall -c -I. -I./Api/core/inc -I./platform/inc ./Api/core/src/vl53l0x_api_core.c -o obj/vl53l0x_api_core.o
mkdir -p obj/
gcc -O0 -g -Wall -c -I. -I./Api/core/inc -I./platform/inc ./Api/core/src/vl53l0x_api_ranging.c -o obj/vl53l0x_api_ranging.o
mkdir -p obj/
gcc -O0 -g -Wall -c -I. -I./Api/core/inc -I./platform/inc ./Api/core/src/vl53l0x_api_strings.c -o obj/vl53l0x_api_strings.o
mkdir -p obj/
gcc -O0 -g -Wall -c -I. -I./Api/core/inc -I./platform/inc ./Api/core/src/vl53l0x_api.c -o obj/vl53l0x_api.o
mkdir -p obj/
gcc -O0 -g -Wall -c -I. -I./Api/core/inc -I./platform/inc ./platform/src/vl53l0x_platform.c -o obj/vl53l0x_platform.o
mkdir -p bin/
ar -rcs bin/libVL53L0X_Rasp.a obj/vl53l0x_api_calibration.o obj/vl53l0x_api_core.o obj/vl53l0x_api_ranging.o obj/vl53l0x_api_strings.o obj/vl53l0x_api.o obj/vl53l0x_platform.o
mkdir -p bin/
gcc -Lbin examples/vl53l0x_SingleRanging_Long_Range_Example.c -lVL53L0X_Rasp -I. -I./Api/core/inc -I./platform/inc -o bin/vl53l0x_SingleRanging_Long_Range_Example
mkdir -p bin/
gcc -Lbin examples/vl53l0x_ContinuousRanging_Example.c -lVL53L0X_Rasp -I. -I./Api/core/inc -I./platform/inc -o bin/vl53l0x_ContinuousRanging_Example
pi@raspberrypi:~/VL53L0X $ cd bin
pi@raspberrypi:~/VL53L0X/bin $ ls
libVL53L0X_Rasp.a vl53l0x_ContinuousRanging_Example vl53l0x_SingleRanging_Long_Range_Example

```

运行示例程序 vl53l0x_SingleRanging_Long_Range_Example:

```

1 Raspberry Pi 3 Model B+
pi@raspberrypi:~/VL53L0X/bin $ sudo ./vl53l0x_SingleRanging_Long_Range_Example
VL53L0X API Simple Ranging example

VL53L0X API Version Error: Your firmware has 1.0.2 (revision 4823). This example requires 1.0.1.
Call of VL53L0X_DataInit
API Status: 0 : No Error
VL53L0X_GetDeviceInfo:
Device Name : VL53L0X ES1 or later
Device Type : VL53L0X
Device ID : VL53L0CBV00H/1$1
ProductRevisionMajor : 1
ProductRevisionMinor : 1
API Status: 0 : No Error
Call of VL53L0X_StaticInit
API Status: 0 : No Error
Call of VL53L0X_PerformRefCalibration
API Status: 0 : No Error
Call of VL53L0X_PerformRefSpadManagement
refSpadCount = 10, isApertureSpads = 1
API Status: 0 : No Error
Call of VL53L0X_SetDeviceMode
API Status: 0 : No Error
Call of VL53L0X_PerformSingleRangingMeasurement
API Status: 0 : No Error
Range Status: 0 : Range Valid
Measured distance: 477

Call of VL53L0X_PerformSingleRangingMeasurement
API Status: 0 : No Error
Range Status: 0 : Range Valid
Measured distance: 474

Call of VL53L0X_PerformSingleRangingMeasurement
API Status: 0 : No Error
Range Status: 0 : Range Valid
Measured distance: 478

Call of VL53L0X_PerformSingleRangingMeasurement
API Status: 0 : No Error
Range Status: 0 : Range Valid
Measured distance: 476

Call of VL53L0X_PerformSingleRangingMeasurement
API Status: 0 : No Error
Range Status: 0 : Range Valid

```

运行示例程序 vl53l0x_ContinuousRanging_Example:

```

1 Raspberry Pi 3 Model B+
pi@raspberrypi:~/VL53L0X/bin $ sudo ./vl53l0x_ContinuousRanging_Example
VL53L0X PAL Continuous Ranging example

VL53L0X API Version Error: Your firmware has 1.0.2 (revision 4823). This example requires 1.0.1.
Call of VL53L0X_DataInit
API Status: 0 : No Error
VL53L0X_GetDeviceInfo:
Device Name : VL53L0X ES1 or later
Device Type : VL53L0X
Device ID : VL53L0CBV0DH/1$1
ProductRevisionMajor : 1
ProductRevisionMinor : 1
Call of VL53L0X_StaticInit
API Status: 0 : No Error
Call of VL53L0X_PerformRefCalibration
API Status: 0 : No Error
Call of VL53L0X_PerformRefSpadManagement
API Status: 0 : No Error
Call of VL53L0X_SetDeviceMode
API Status: 0 : No Error
Call of VL53L0X_StartMeasurement
API Status: 0 : No Error
In loop measurement 0: 512
In loop measurement 1: 515
In loop measurement 2: 517
In loop measurement 3: 511
In loop measurement 4: 506
In loop measurement 5: 500
In loop measurement 6: 503
In loop measurement 7: 508
In loop measurement 8: 509
In loop measurement 9: 501
In loop measurement 10: 504
In loop measurement 11: 509
In loop measurement 12: 501
In loop measurement 13: 506
In loop measurement 14: 505
In loop measurement 15: 507
In loop measurement 16: 504
In loop measurement 17: 504
In loop measurement 18: 504
In loop measurement 19: 506
In loop measurement 20: 499
In loop measurement 21: 505
In loop measurement 22: 496
  
```

用于 Arduino

硬件连接

硬件连接到开发板 UNO PLUS:

VL53L0X Distance Sensor	Arduino
VCC	3.3V
GND	GND
SDA	SDA
SCL	SCL

预期结果

把示例程序 VL53L0X-Arduino-Library 整个文件夹复制到 Arduino IDE 安装路径下的 Library 目录下

打开 Arduino IDE --> File --> Examples --> VL53L0X-Arduino-Library

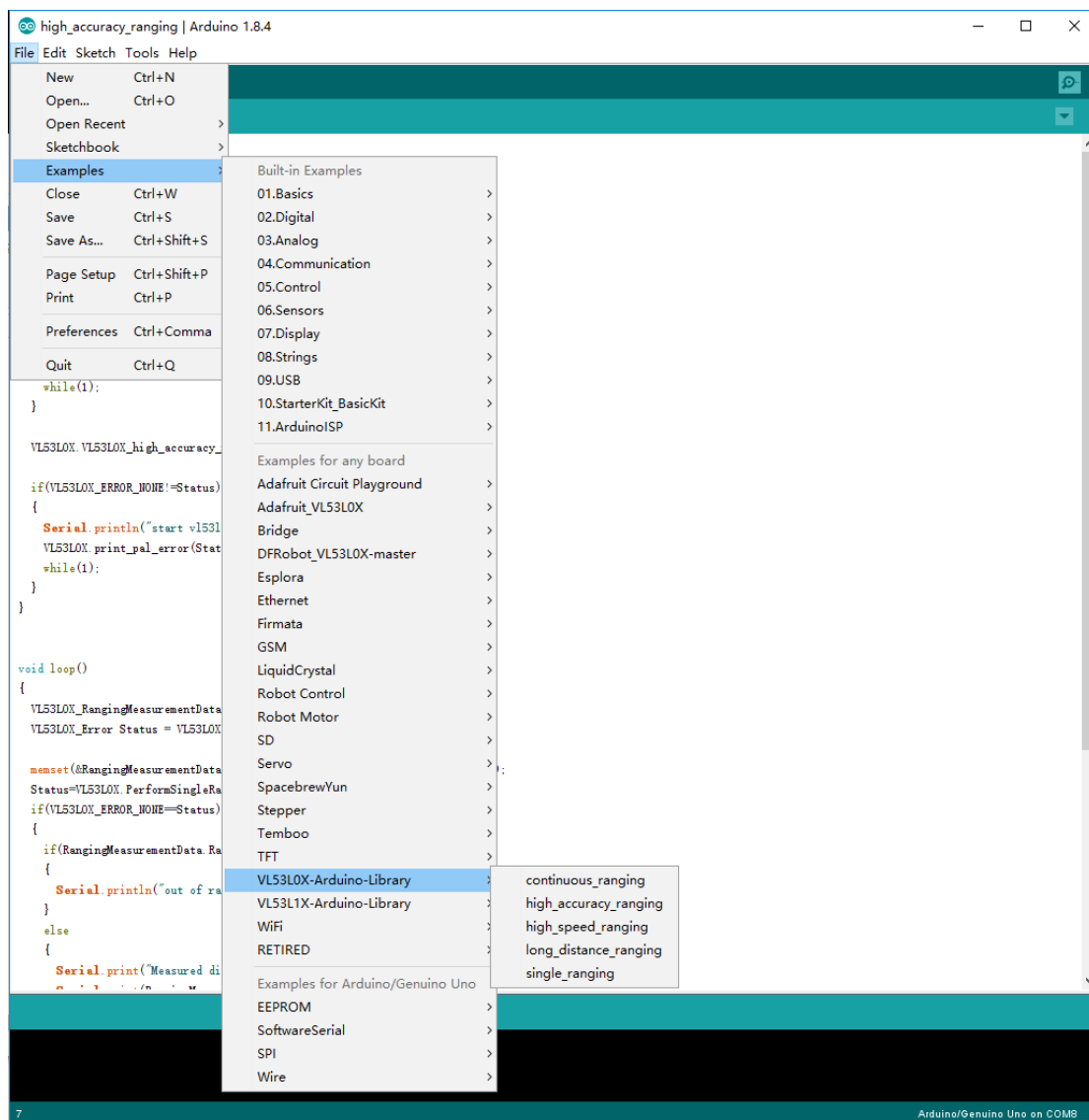

编译下载 5 个示例程序，现象如下：

high_accuracy_ranging: 高精度测距，测量时间长

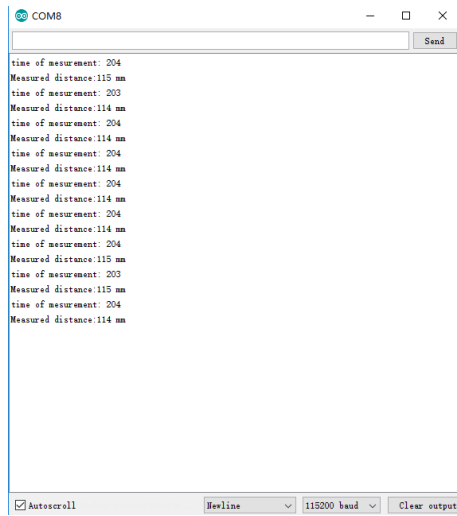

```
COM8
time of measurement: 204
Measured distance:115 mm
time of measurement: 203
Measured distance:114 mm
time of measurement: 204
Measured distance:114 mm
time of measurement: 204
Measured distance:114 mm
time of measurement: 204
Measured distance:114 mm
time of measurement: 204
Measured distance:114 mm
time of measurement: 204
Measured distance:115 mm
time of measurement: 203
Measured distance:115 mm
time of measurement: 204
Measured distance:114 mm
```

Autoscroll | Newline | 115200 baud | Clear output

high_speed_ranging: 高速测距，测量时间短，精度不高

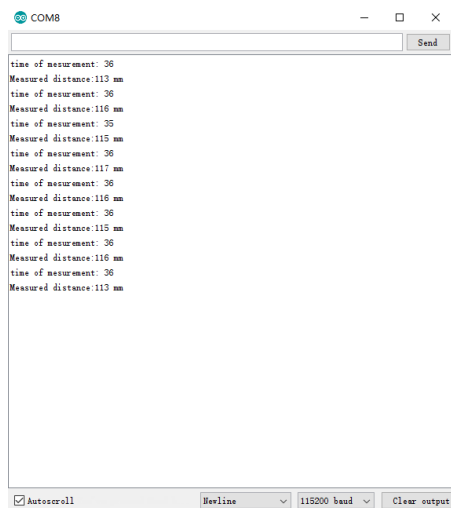

```
COM8
time of measurement: 36
Measured distance:113 mm
time of measurement: 36
Measured distance:110 mm
time of measurement: 35
Measured distance:115 mm
time of measurement: 36
Measured distance:117 mm
time of measurement: 36
Measured distance:116 mm
time of measurement: 36
Measured distance:115 mm
time of measurement: 36
Measured distance:116 mm
time of measurement: 36
Measured distance:113 mm
```

Autoscroll | Newline | 115200 baud | Clear output

long_distance_ranging: 长距离测距，测量范围广

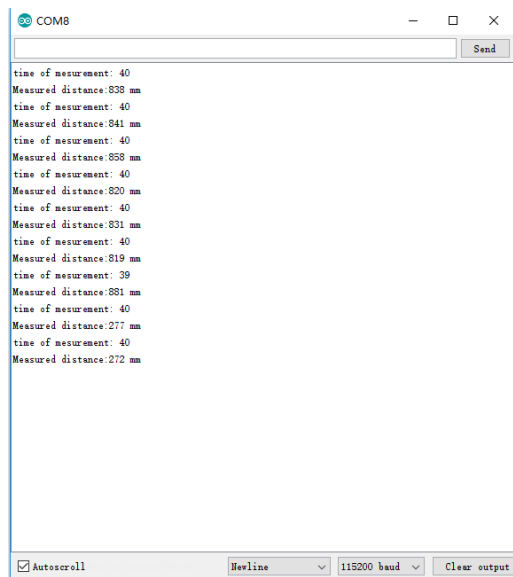

```
COM8
time of measurement: 40
Measured distance: 838 mm
time of measurement: 40
Measured distance: 841 mm
time of measurement: 40
Measured distance: 858 mm
time of measurement: 40
Measured distance: 820 mm
time of measurement: 40
Measured distance: 831 mm
time of measurement: 40
Measured distance: 819 mm
time of measurement: 39
Measured distance: 881 mm
time of measurement: 40
Measured distance: 277 mm
time of measurement: 40
Measured distance: 272 mm

Autoscroll Newline 115200 baud Clear output
```

single_ranging: 单独模式测距模式

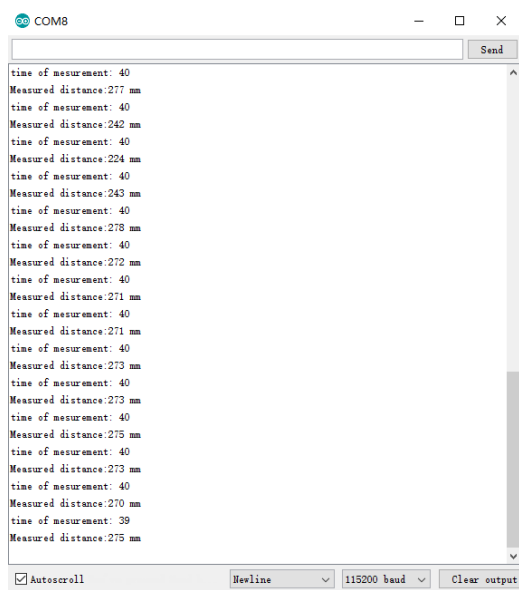

```
COM8
time of measurement: 40
Measured distance: 277 mm
time of measurement: 40
Measured distance: 242 mm
time of measurement: 40
Measured distance: 224 mm
time of measurement: 40
Measured distance: 243 mm
time of measurement: 40
Measured distance: 278 mm
time of measurement: 40
Measured distance: 272 mm
time of measurement: 40
Measured distance: 271 mm
time of measurement: 40
Measured distance: 271 mm
time of measurement: 40
Measured distance: 273 mm
time of measurement: 40
Measured distance: 273 mm
time of measurement: 40
Measured distance: 275 mm
time of measurement: 40
Measured distance: 273 mm
time of measurement: 40
Measured distance: 270 mm
time of measurement: 39
Measured distance: 275 mm

Autoscroll Newline 115200 baud Clear output
```

continuous_ranging: 连续测距模式

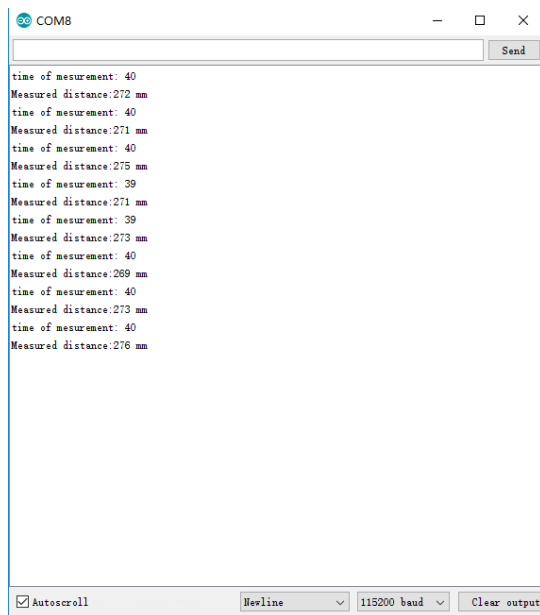

```

time of mesurement: 40
Measured distance:272 mm
time of mesurement: 40
Measured distance:271 mm
time of mesurement: 40
Measured distance:275 mm
time of mesurement: 39
Measured distance:271 mm
time of mesurement: 39
Measured distance:273 mm
time of mesurement: 40
Measured distance:269 mm
time of mesurement: 40
Measured distance:273 mm
time of mesurement: 40
Measured distance:276 mm
    
```

更多关于测试模式相关的细节请查阅 VL53L0X API。

用于 STM32

本例程使用的开发板为 NUCLEO-F401RE 和 XNUCLEO-F411RE

硬件连接

硬件连接到开发板 XNUCLEO-F411RE / NUCLEO-F401RE:

VL53L0X Distance Sensor	XNUCLEO-F411RE/NUCLEO-F401RE
VCC	3.3V
GND	GND
SDA	SDA
SCL	SCL

VL53L0X_GUI 演示预期结果

- 1、按硬件连接说明接上 NUCLEO-F401RE 开发板
- 2、安装并运行 ST 官方的 VL53L0X_GUI 工具，软件会自动烧写测试固件到开发板上

（说明：本例只能用 NUCLEO-F401RE 板子，且示例程序源码 ST 不开源）

3、切换到 Low-Power Autonomous, Distance Mode 选择 Short, 点击 Start, 软件显示距离曲线

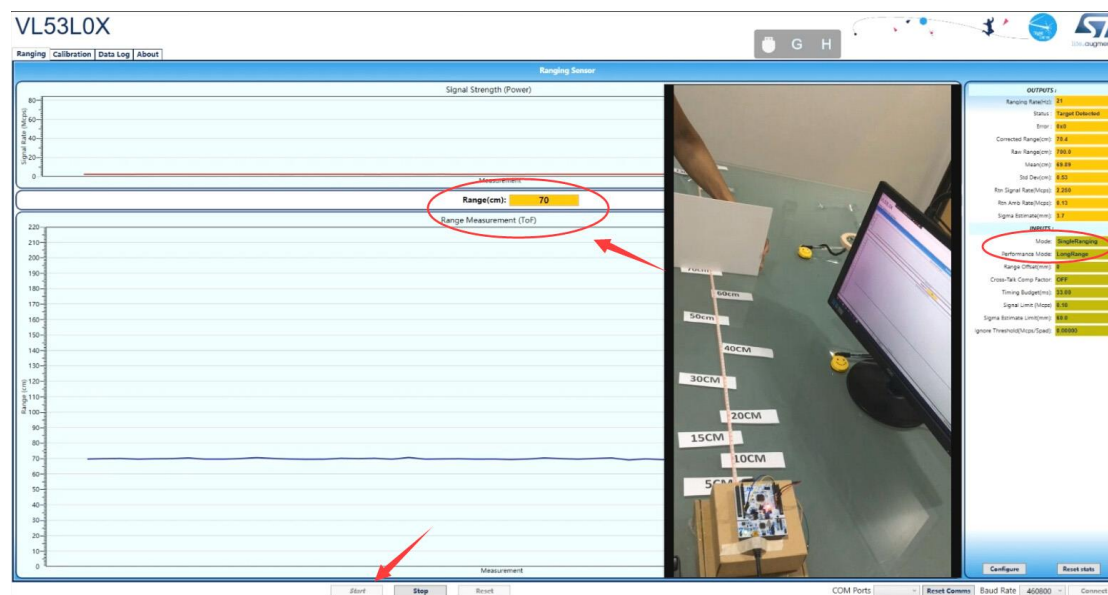

更多关于 VL53L0X 的 STM32 示例程序相关资料可访问 ST 官网查看。

X-ON Electronics

Largest Supplier of Electrical and Electronic Components

Click to view similar products for [Multiple Function Sensor Development Tools](#) category:

Click to view products by [Waveshare](#) manufacturer:

Other Similar products are found below :

[RD-KL25-AGMP01](#) [PTC-04-DB-ACT](#) [FRDM-K22F-SA9500](#) [EV_ICM-20649](#) [MULTI-SENSE-GEVB](#) [FRDM-STBC-SA9500](#) [BRKT-STBC-SA9500](#) [STEVAL-MKIT01V1](#) [EVAL-CN0411-ARDZ](#) [SEN0004](#) [KT-TVOC-200-TB200A](#) [KT-NmHc-200-TB200A](#) [SEN0344](#) [PIM520](#) [PIM518](#) [PIM519](#) [PIM510](#) [103030375](#) [ZSSC4132KIT](#) [ADIS16505-3/PCBZ](#) [SEN-16794](#) [PIM502](#) [SEN0359](#) [4829](#) [EV26Q64A](#) [EVAL-AD7746RDZ](#) [EVAL-AD7746HDZ](#) [AS7022-EVALKIT](#) [RTK0ESXB10C00001BJ](#) [MAX30134EVSYS#](#) [EV-CBM-PIONEER1-1Z](#) [EVAL-ADPD188BIZ-S2](#) [EVAL-ADCM-1](#) [EVAL-CN0507-ARDZ](#) [SI118X-KIT](#) [ALTEHTG2SMIP](#) [EVAL-CN0533-EBZ](#) [MIKROE-4305](#) [MAX30101WING#](#) [MIKROE-4192](#) [MIKROE-4049](#) [OB1203SD-U-EVK](#) [OB1203SD-BT-EVK](#) [MIKROE-4037](#) [101990644](#) [MIKROE-4267](#) [MIKROE-4265](#) [MIKROE-4330](#) [ARG-LDKT](#) [EVAL-CN0503-ARDZ](#)