

High PSRR, High speed, CMOS LDO

General Description

The WR0332 series is a high accuracy, low noise, high speed, low dropout CMOS Linear regulator with high ripple rejection. The devices offer a new level of cost-effective performance in cellular phones, laptop and notebook computers, and other portable devices.

The WR0332 has the fold-back maximum output current which depends on the output voltage. So the current limit functions both as a short circuit protection and as an output current limiter.

The WR0332 regulators are available in standard SOT23-3 package, SOT23-5 package and DFN1x1-4 Package. Standard products are Pb-free and Halogen-free.

Features

- Input Voltage: 2.0V~5.5V
- Output Voltage: 1.0V~3.3V
- Output Current: 300mA
- PSRR: 70dB@1KHz
- Dropout Voltage: 220mV @ $I_{OUT} = 300mA$
- Operating Temperature: -40~+125°C
- Shut-down Current: < 1 μ A
- Quiescent Current: 60 μ A Typ.
- Recommend Capacitor: 1 μ F

Applications

- MP3/MP4 Players
- Cellphones, radiophone, digital cameras
- Bluetooth, wireless handsets
- Others portable electronic device

Typical Application

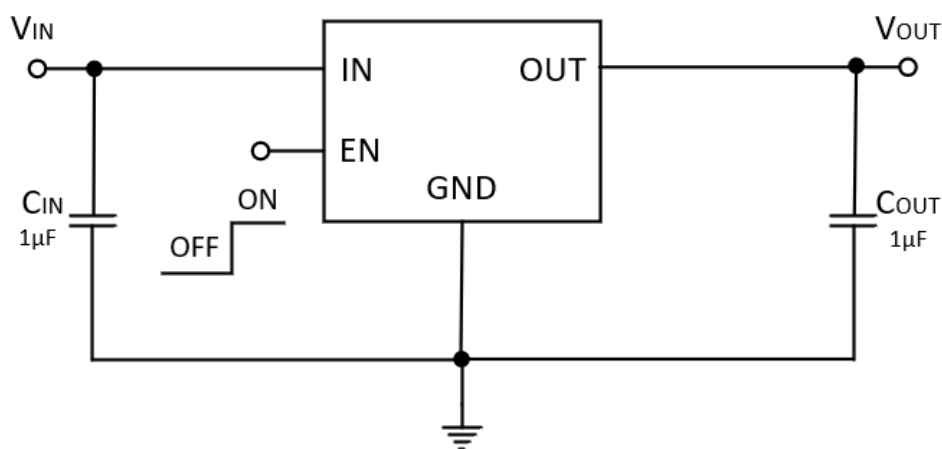

Pin Configuration

(Top View)

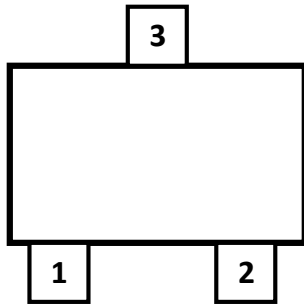

SOT23-3

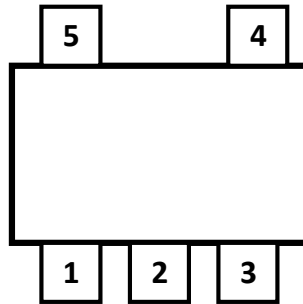

SOT23-5

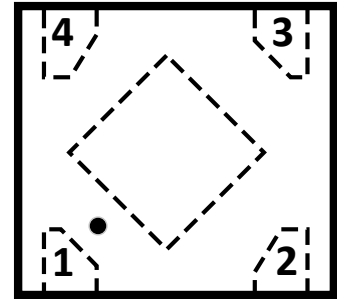

DFN-4

Pin Description

Pin Number			Pin Name	Description
SOT23-3	SOT23-5	DFN-4		
3	1	4	IN	Input Voltage
1	2	2	GND	Ground
-	3	3	EN	Enable, Active High
-	4	-	NC	NC
2	5	1	OUT	Output Voltage
-	-		EPAD	Exposed pad should be connected directly to the GND pin. Soldered to a large ground copper plane allows for effective heat removal.

Absolute Maximum Ratings

Parameter		Rating	Unit
Input voltage range		-0.3 ~ 6.5	V
EN Input voltage range		-0.3 ~ V _{IN}	V
Output voltage range		-0.3 ~ V _{IN}	V
Power Dissipation P _D @ T _A = 25°C	SOT23-3 & SOT23-5	500	mW
	DFN-4	500	mW
Thermal Resistance, θ _{JA}	SOT23-3 & SOT23-5	250	°C/W
	DFN-4	250	°C/W
Junction Temperature		150	°C
Lead Temperature Range		260	°C
Storage Temperature Range		-55 ~ 150	°C
ESD Susceptibility	HBM	±4000	V

Recommended Operating Conditions

Parameter	Rating	Unit
Operating Supply voltage	2.0 ~ 5.5	V
Operating Temperature Range	-40 ~ 125	°C

Electrical Characteristics

($T_A=25\text{ }^\circ\text{C}$, $V_{IN}=V_{OUT}+1\text{V}$, $C_{IN}=C_{OUT}=1\mu\text{F}$, unless otherwise noted)

symbol	Parameter	Test Condition	Min	Typ	Max	Unit
V_{OUT}	Output Voltage	$V_{OUT} \leq 1.5\text{V}$, $V_{IN}=2.7\text{V}$, $I_{OUT}=1\text{mA}$	0.97 V_{OUT}	V_{OUT}	1.03 V_{OUT}	V
		$V_{OUT} > 1.5\text{V}$, $I_{OUT}=1\text{mA}$	0.98 V_{OUT}	V_{OUT}	1.02 V_{OUT}	
V_{DO}	Dropout Voltage ¹	$V_{OUT}=3.3\text{V}$, $I_{OUT}=300\text{mA}$		220	330	mV
		$V_{OUT}=3.0\text{V}$, $I_{OUT}=300\text{mA}$		240	360	
		$V_{OUT}=2.8\text{V}$, $I_{OUT}=300\text{mA}$		250	375	
		$V_{OUT}=2.5\text{V}$, $I_{OUT}=300\text{mA}$		280	420	
		$V_{OUT}=2.2\text{V}$, $I_{OUT}=300\text{mA}$		310	465	
		$V_{OUT}=1.8\text{V}$, $I_{OUT}=300\text{mA}$		400	600	
I_{OUT}	Maximum Output Current ²	$V_{EN}=V_{IN}$	300			mA
LNR	Line Regulation	$V_{OUT}=3.3\text{V}$, $V_{IN}=4.3\sim 5.5\text{V}$, $I_{OUT}=1\text{mA}$		0.05	0.1	%/V
LDR	Load Regulation ³	$V_{OUT}=3.3\text{V}$, $I_{OUT}=1\sim 300\text{mA}$		15		mV
I_Q	Quiescent Current	$V_{OUT}=3.3\text{V}$, $I_{OUT}=0\text{mA}$		60	80	μA
I_{SHDN}	Shut-down Current	$V_{EN} = 0\text{V}$		0.1	1.0	μA
I_{SHORT}	Short Current	$V_{EN}=V_{IN}$, V_{OUT} Short to GND		150		mA
PSRR	Power Supply Ripple Rejection	$V_{IN}=(V_{OUT}+1\text{V})_{DC}+0.5\text{V}_{P-P}$ $F=1\text{KHz}$, $I_{OUT}=10\text{mA}$, @ $V_{OUT}=3.3\text{V}$		70		dB
		$V_{IN}=(V_{OUT}+1\text{V})_{DC}+0.5\text{V}_{P-P}$ $F=10\text{KHz}$, $I_{OUT}=10\text{mA}$, @ $V_{OUT}=3.3\text{V}$		55		
V_{NO}	Output noise voltage	10Hz to 100KHz, $C_{OUT}=1\mu\text{F}$		140		μV_{RMS}
V_{IH}	EN logic high voltage	$V_{IN}=5.5\text{V}$, $I_{OUT}=1\text{mA}$	1.2			V
V_{IL}	EN logic low voltage	$V_{IN}=5.5\text{V}$, $I_{OUT}=1\text{mA}$			0.4	V
T_{SD}	Thermal shutdown threshold			165		$^\circ\text{C}$
ΔT_{SD}	Thermal shutdown hysteresis			30		$^\circ\text{C}$
R_{DIS}	Output Discharge resistance	$V_{IN}=4.0\text{V}$, $V_{EN}=0\text{V}$		150		Ω

Note1: The dropout voltage is defined as ($V_{IN}-V_{OUT}$) when V_{OUT} is 100mV below the target value of V_{OUT} . V_{DO} is measured for devices with $V_{OUT(nom)} \geq 1.8\text{V}$.

Note2: Maximum output current is affected by the PCB layout, size of metal trace, the thermal conduction path between metal layers, ambient temperature and the other environment factors of system. Attention should be paid to the dropout voltage when $V_{IN} < V_{OUT} + V_{DROP}$.

Note3: The Load regulation is measured using pulse techniques with duty cycle < 5%.

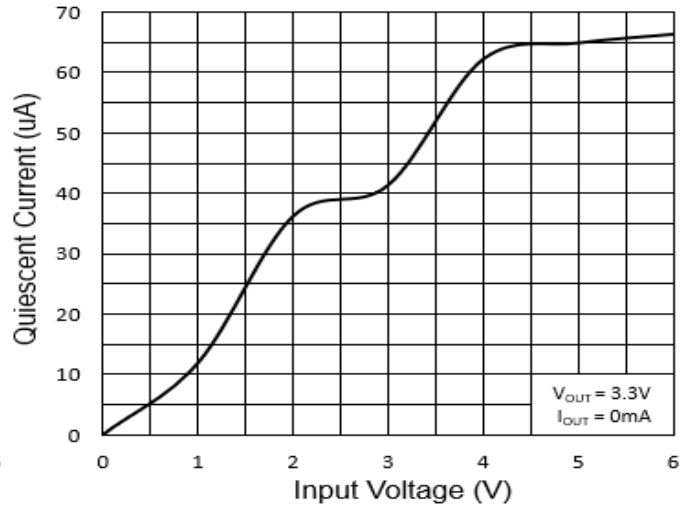
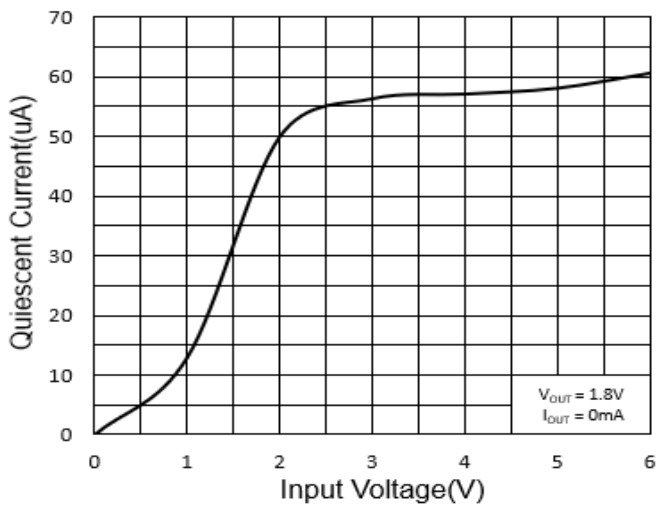
Typical Characteristics ($T_a=25^\circ\text{C}$, $V_{IN}=V_{OUT}+1\text{V}$, $C_{IN}=C_{OUT}=1\mu\text{F}$, unless otherwise noted)

Quiescent Current vs. Supply Voltage

Quiescent Current vs. Supply Voltage

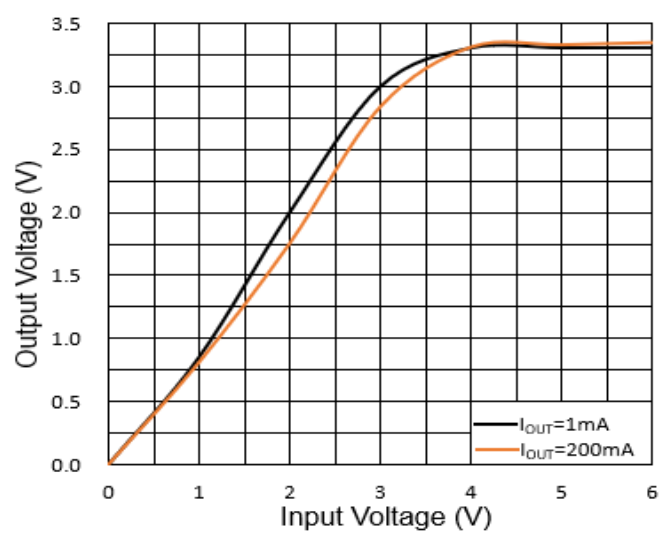
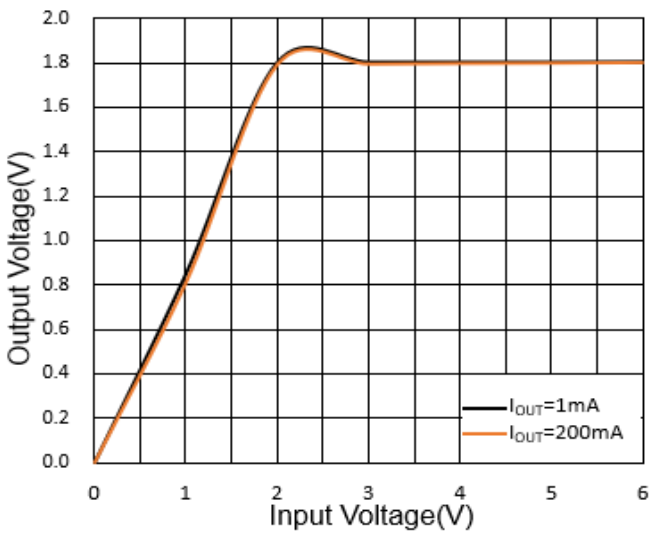

Output Voltage vs. Supply Voltage

Output Voltage vs. Supply Voltage

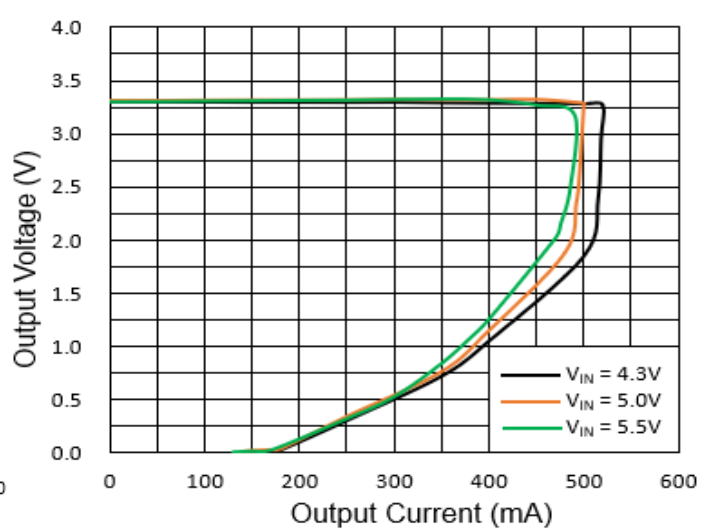
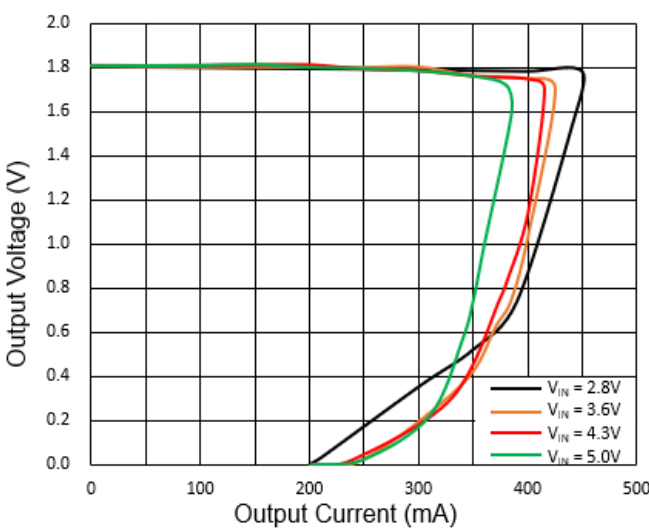

Output Voltage vs. Output Current

Output Voltage vs. Output Current

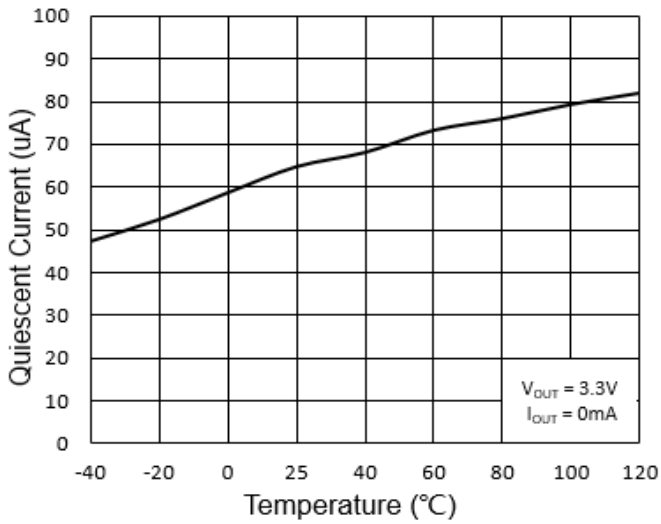

Quiescent Current vs. Temperature

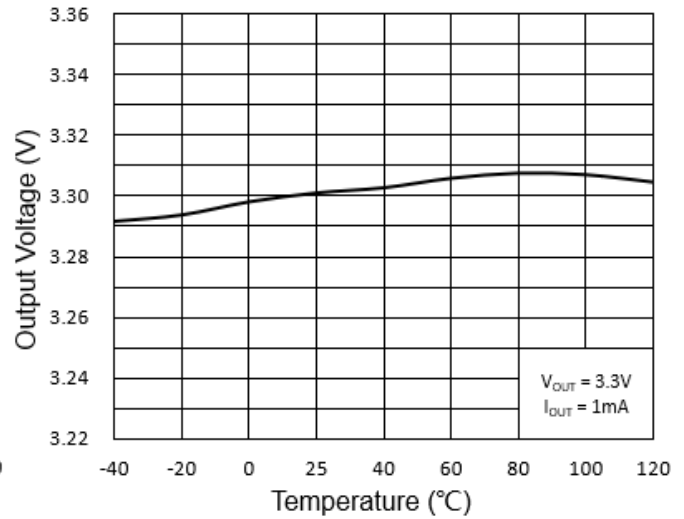

Output Voltage vs. Temperature

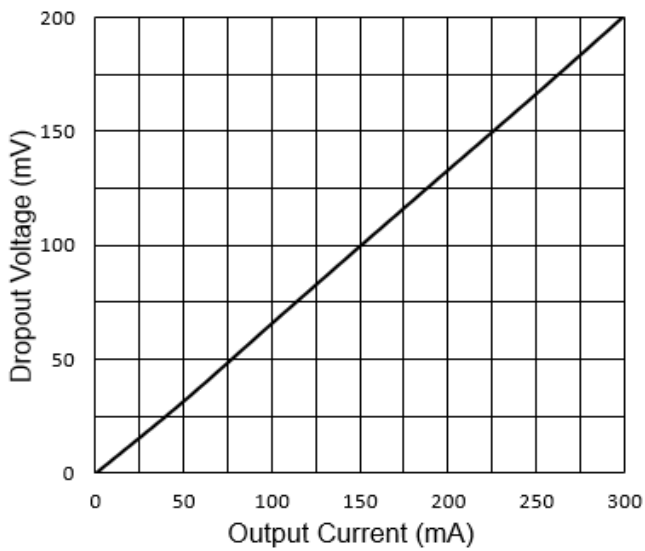

Dropout Voltage vs. Output Current

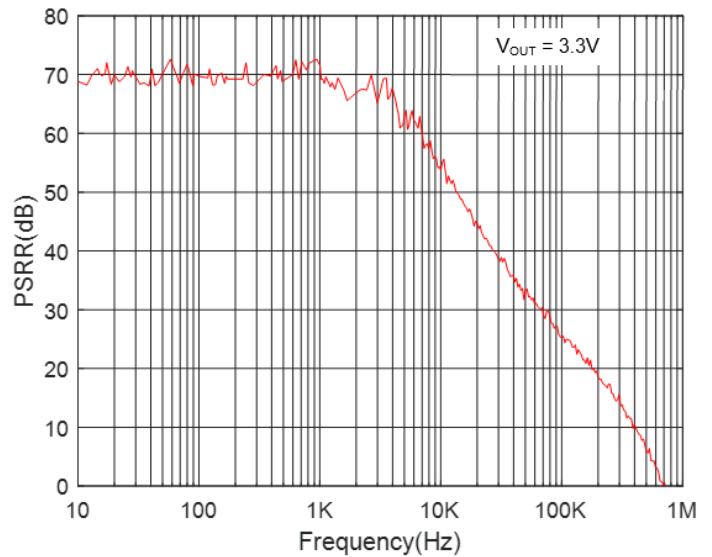

Power Supply Rejection Ratio vs. Frequency

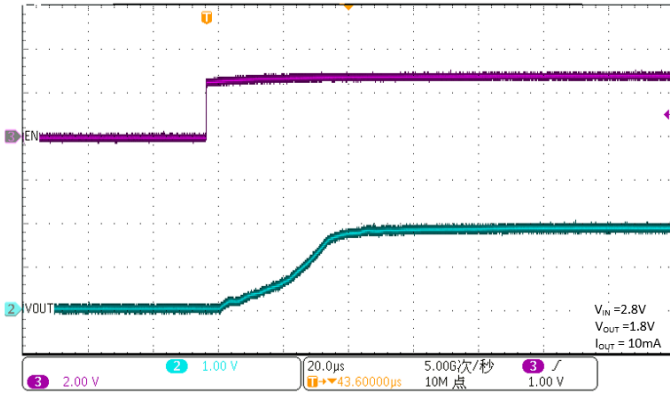

Soft Start from EN

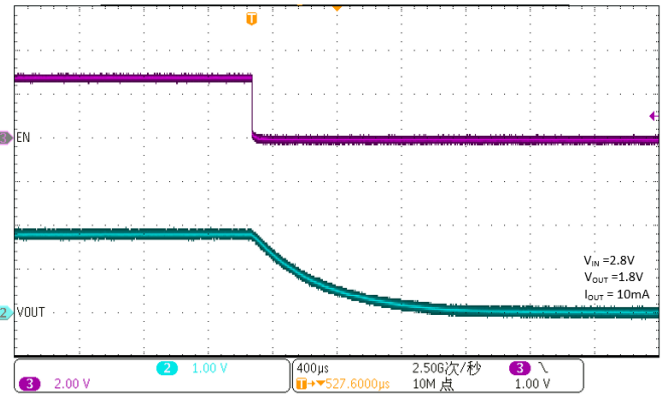

EN Shutdown

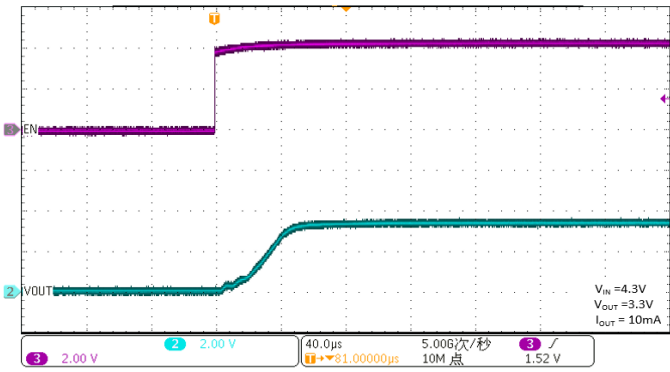

Soft Start from EN

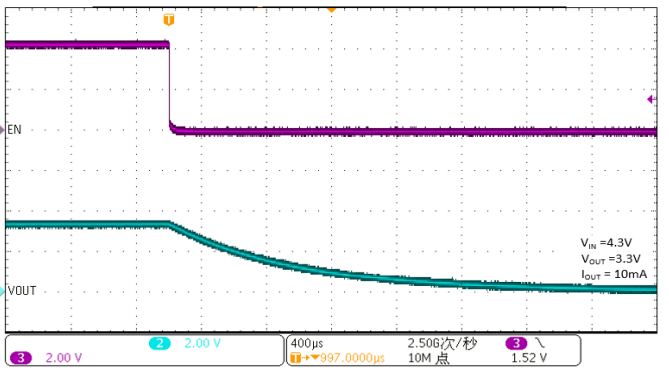

EN Shutdown

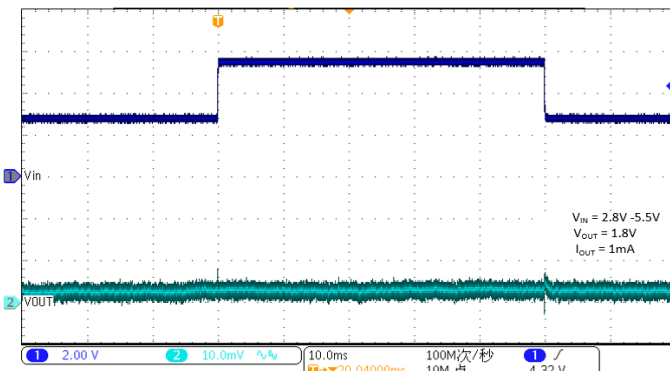

Line Transient

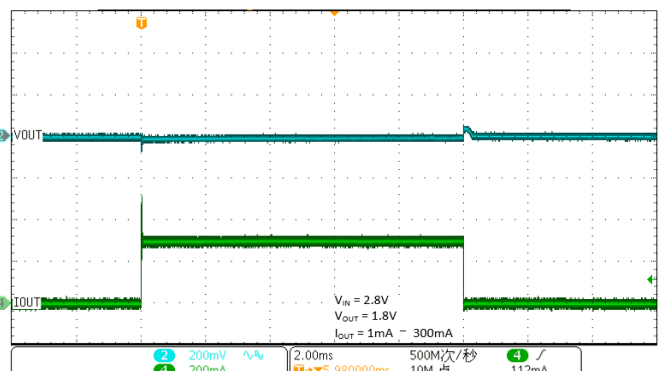

Load Transient

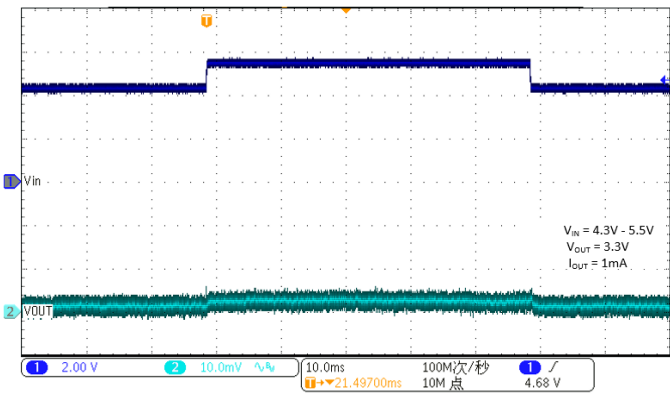

Line Transient

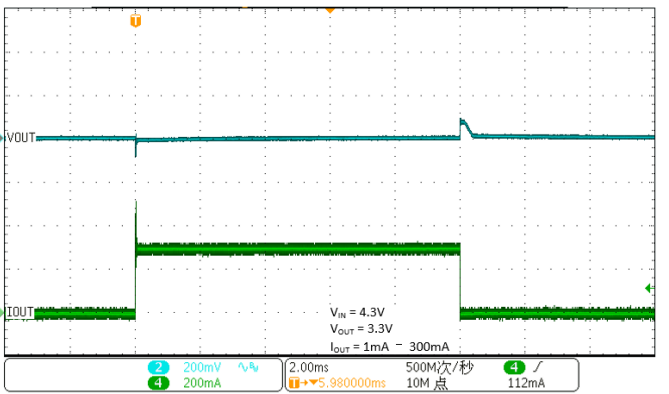

Load Transient

Block Diagram

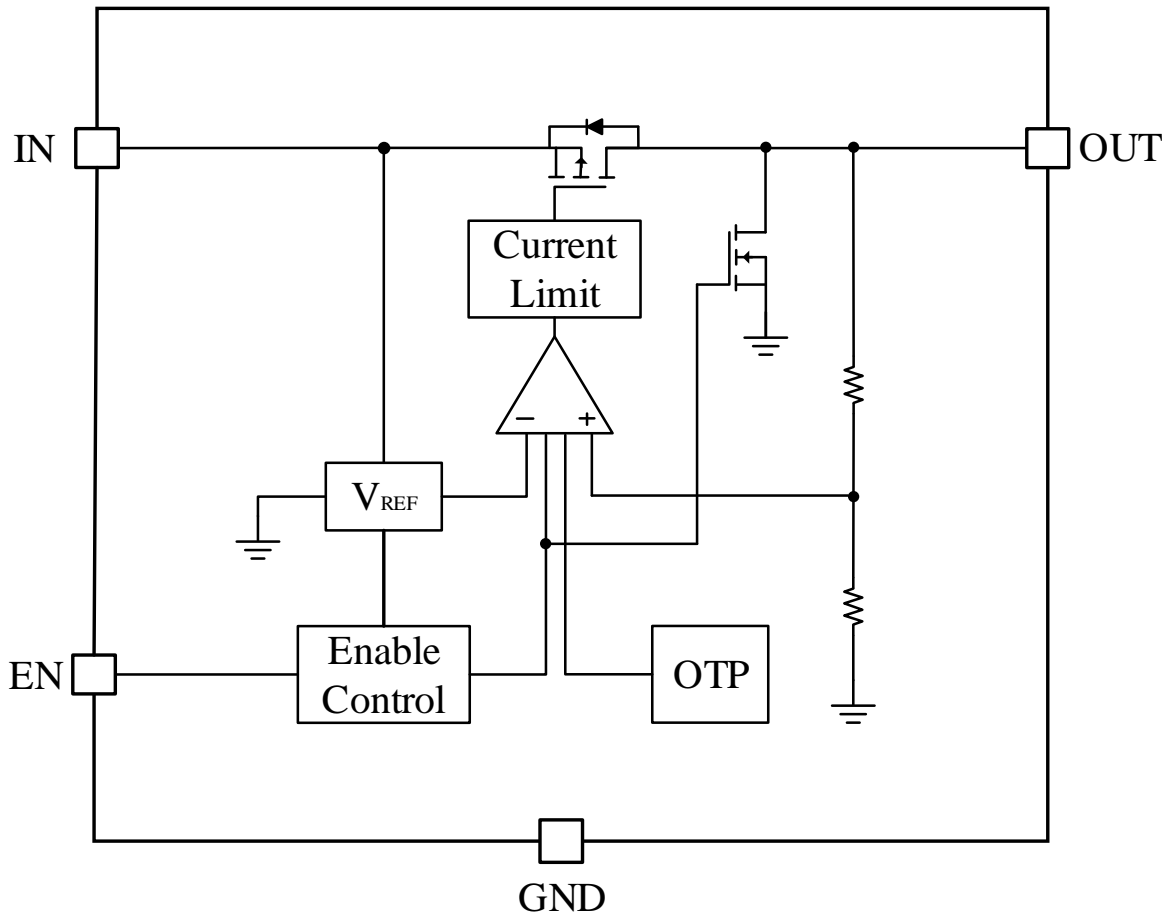

Package Information

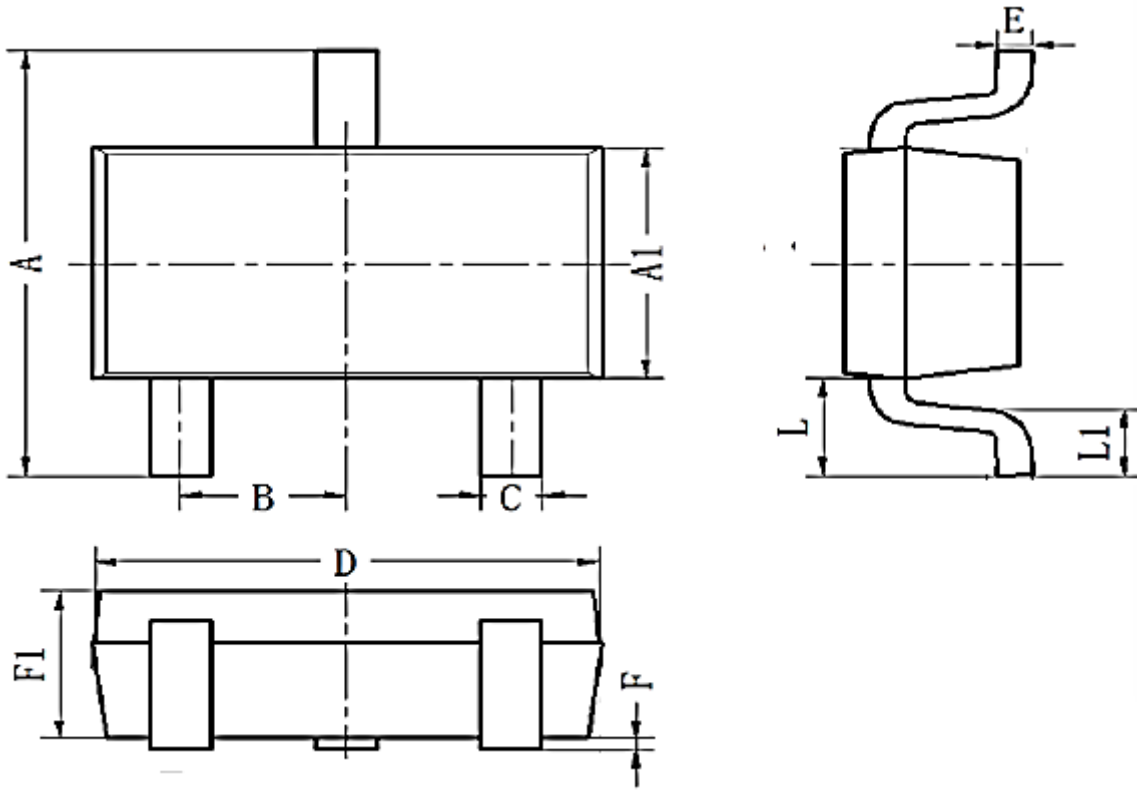

SOT 23-3

SYMBOL	DIMENSIONS IN MILLIMETERS		
	MIN	NOM	MAX
A	2.60	2.80	3.00
A1	1.50	1.60	1.70
B	0.95BSC		
C	0.25	0.40	0.50
D	2.82	2.92	3.02
E	0.10	0.15	0.20
L	0.59REF		
L1	0.30	0.45	0.60
F1	0.90	1.10	1.30
F	0.00	0.08	0.15

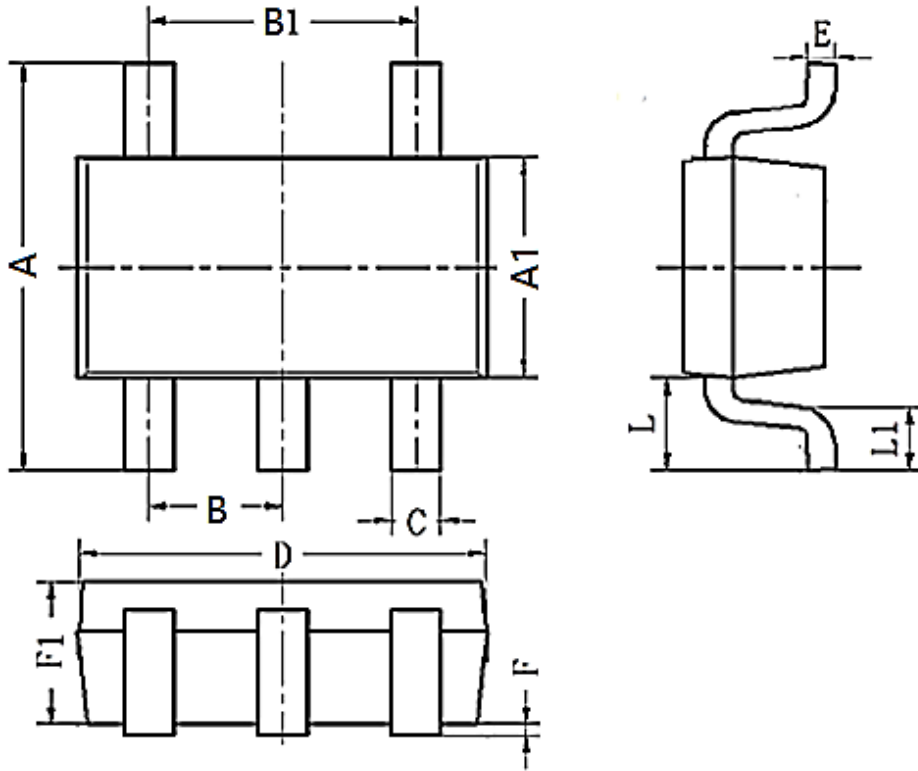

SOT 23-5

SYMBOL	DIMENSIONS IN MILLIMETERS		
	MIN	NOM	MAX
A	2.60	2.80	3.00
A1	1.50	1.60	1.70
B	0.95BSC		
B1	1.90BSC		
C	0.25	0.40	0.50
D	2.82	2.92	3.02
E	0.10	0.15	0.20
F	0.00	0.08	0.15
L	0.59REF		
F1	0.90	1.10	1.30
L1	0.30	0.45	0.60

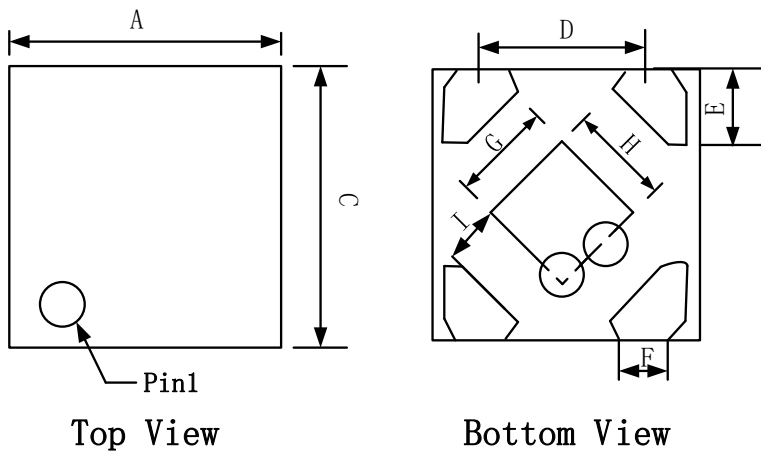

DETAIL A

Pin 1 ID and Tie Bar Mark Options

Note: The configuration of the Pin 1 identifier is optional, but must be located within the zone indicated.



Side View

DFN-4

SYMBOL	DIMENSIONS IN MILLIMETERS		
	MIN	NOM	MAX
A	0.950	1.000	1.050
B	0.320	0.370	0.420
C	0.950	1.000	1.050
D	0.650BSC		
E	0.170	0.270	0.370
F	0.130	0.235	0.300
G	0.430	0.485	0.540
H	0.430	0.485	0.540
I	0.200REF		

Ordering Information

Part Number	Output Voltage	Package	Packing Quantity	Marking*
WR0332-10A30R	1.0V	SOT23-3	3K/Reel	WR0332 10 (J)XXXX
WR0332-105A30R	1.05V	SOT23-3	3k/Reel	WR0332 105 (J)XXXX
WR0332-11A30R	1.1V	SOT23-3	3k/Reel	WR0332 11 (J)XXXX
WR0332-12A30R	1.2V	SOT23-3	3K/Reel	WR0332 12 (J)XXXX
WR0332-15A30R	1.5V	SOT23-3	3k/Reel	WR0332 15 (J)XXXX
WR0332-18A30R	1.8V	SOT23-3	3k/Reel	WR0332 18 (J)XXXX
WR0332-20A30R	2.0V	SOT23-3	3k/Reel	WR0332 20 (J)XXXX
WR0332-22A30R	2.2V	SOT23-3	3k/Reel	WR0332 22 (J)XXXX
WR0332-25A30R	2.5V	SOT23-3	3k/Reel	WR0332 25 (J)XXXX
WR0332-28A30R	2.8V	SOT23-3	3k/Reel	WR0332 28 (J)XXXX
WR0332-30A30R	3.0V	SOT23-3	3k/Reel	WR0332 30 (J)XXXX
WR0332-33A30R	3.3V	SOT23-3	3k/Reel	WR0332 33 (J)XXXX
WR0332-10A50R	1.0V	SOT23-5	3K/Reel	WR0332 10 (J)XXXX
WR0332-105A50R	1.05V	SOT23-5	3k/Reel	WR0332 105 (J)XXXX
WR0332-11A50R	1.1V	SOT23-5	3k/Reel	WR0332 11 (J)XXXX
WR0332-12A50R	1.2V	SOT23-5	3k/Reel	WR0332 12 (J)XXXX
WR0332-15A50R	1.5V	SOT23-5	3k/Reel	WR0332 15 (J)XXXX
WR0332-18A50R	1.8V	SOT23-5	3k/Reel	WR0332 18 (J)XXXX
WR0332-20A50R	2.0V	SOT23-5	3k/Reel	WR0332 20 (J)XXXX
WR0332-22A50R	2.2V	SOT23-5	3k/Reel	WR0332 22 (J)XXXX
WR0332-25A50R	2.5V	SOT23-5	3k/Reel	WR0332 25 (J)XXXX
WR0332-27A50R	2.7V	SOT23-5	3k/Reel	WR0332 27 (J)XXXX
WR0332-28A50R	2.8V	SOT23-5	3k/Reel	WR0332 28 (J)XXXX
WR0332-29A50R	2.9V	SOT23-5	3k/Reel	WR0332 29 (J)XXXX
WR0332-30A50R	3.0V	SOT-23-5	3k/Reel	WR0332 30 (J)XXXX
WR0332-33A50R	3.3V	SOT-23-5	3k/Reel	WR0332 33 (J)XXXX
WR0332-10FF4R	1.0V	DFN-4	10k/Reel	332 10
WR0332-105FF4R	1.05V	DFN-4	10k/Reel	332 105
WR0332-11FF4R	1.1V	DFN-4	10k/Reel	332 11
WR0332-12FF4R	1.2V	DFN-4	10k/Reel	332 12
WR0332-15FF4R	1.5V	DFN-4	10k/Reel	332 15
WR0332-18FF4R	1.8V	DFN-4	10k/Reel	332 18
WR0332-185FF4R	1.85V	DFN-4	10k/Reel	332 185

Part Number	Output Voltage	Package	Packing Quantity	Marking*
WR0332-20FF4R	2.0V	DFN-4	10k/Reel	332 20
WR0332-21FF4R	2.1V	DFN-4	10k/Reel	332 21
WR0332-22FF4R	2.2V	DFN-4	10k/Reel	332 22
WR0332-25FF4R	2.5V	DFN-4	10k/Reel	332 25
WR0332-27FF4R	2.7V	DFN-4	10k/Reel	332 27
WR0332-28FF4R	2.8V	DFN-4	10k/Reel	332 28
WR0332-30FF4R	3.0V	DFN-4	10k/Reel	332 30
WR0332-33FF4R	3.3V	DFN-4	10k/Reel	332 33

* XXXX is variable. The chip is universal whether the marking has j or not.

Contact Information

No.1001, Shiwan(7) Road, Pudong District, Shanghai, P.R.China.201202

Tel: 86-21-68960674 Fax: 86-21-50757680 Email: market@way-on.com

WAYON website: <http://www.way-on.com>

For additional information, please contact your local Sales Representative.

 is registered trademark of Wayon Corporation.

Specifications are subject to change without notice.

The device characteristics and parameters in this data sheet can and do vary in different applications and actual device performance may vary over time.

Users should verify actual device performance in their specific applications.

X-ON Electronics

Largest Supplier of Electrical and Electronic Components

Click to view similar products for [Linear Voltage Regulators](#) category:

Click to view products by [Wayon](#) manufacturer:

Other Similar products are found below :

[LV56831P-E](#) [LV5684PVD-XH](#) [MCDTSA6-2R](#) [L7815ACV-DG](#) [PQ3DZ53U](#) [LV56801P-E](#) [TLE42794G](#) [L78L05CZ/1SX](#) [L78LR05DL-MA-E](#) [636416C](#) [714954EB](#) [BA033LBSG2-TR](#) [LV5680P-E](#) [L78M15CV-DG](#) [L79M05T-E](#) [TLS202A1MBVHTSA1](#) [L78LR05D-MA-E](#) [NCV317MBTG](#) [NTE7227](#) [LV5680NPVC-XH](#) [LT1054CN8](#) [MP2018GZD-5-Z](#) [MP2018GZD-33-Z](#) [MIC5281-3.3YMM](#) [MC78L06BP-AP](#) [TA48LS05F\(TE85L,F\)](#) [TA78L12F\(TE12L,F\)](#) [TC47BR5003ECT](#) [TCR2LN12,LF\(S](#) [TCR2LN28,LF\(S](#) [TCR2LN30,LF\(S](#) [TCR3DF295,LM\(CT](#) [TCR3DF40,LM\(CT](#) [BA178M20CP-E2](#) [L78M12ABDT](#) [LM7812SX/NOPB](#) [LR645N3-G-P003](#) [LR645N3-G-P013](#) [ZXTR2005P5-13](#) [SCD7812BTG](#) [TCR3DF335,LM\(CT](#) [ZXTR2012K-13](#) [TLE42994E V33](#) [ZXTR2008K-13](#) [ZXTR2005K-13](#) [L88R05DL-E](#) [ADP3300ARTZ-2.7RL7](#) [LM120K-15/883](#) [IFX54441LDVXUMA1](#) [LM317D2T-TR](#)