



Jiangsu Weida Semiconductor Co., Ltd.

BT134 Series 4A Triacs

DESCRIPTION:

With low holding and latching current, BT134 Series triacs are especially recommended for use on middle and small resistance type power load.

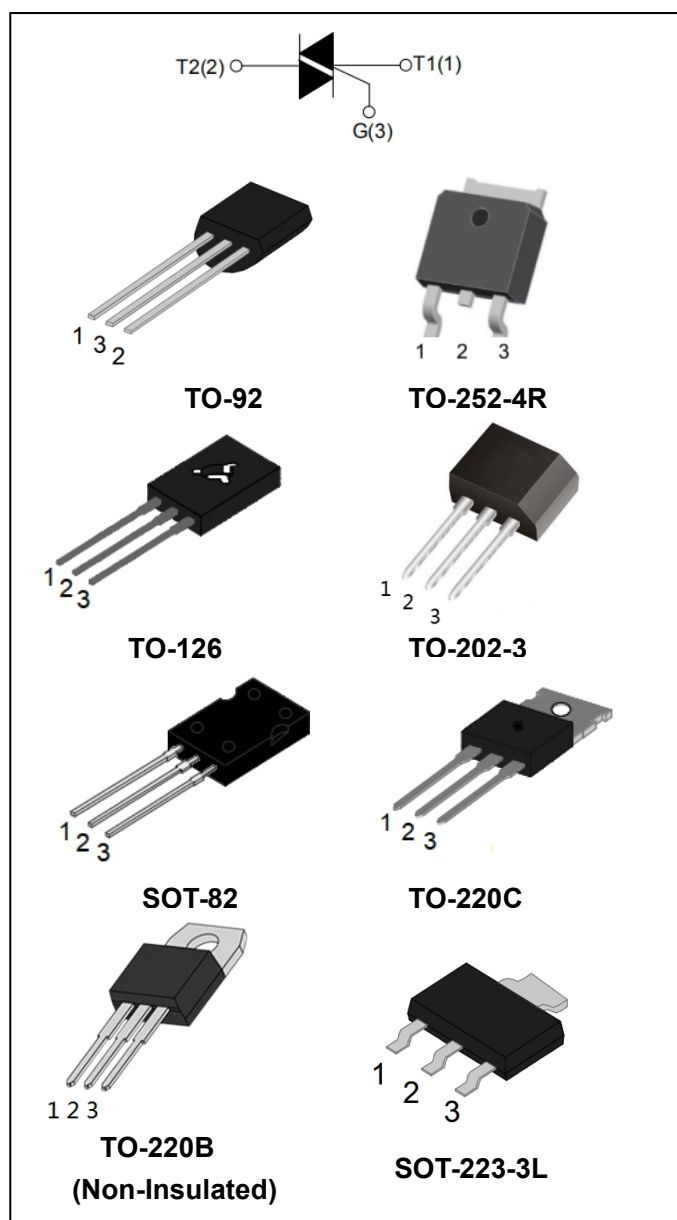

MAIN FEATURES:

symbol	value	unit
$I_{T(RMS)}$	4	A
V_{DRM}/V_{RRM}	600/800	V
V_{TM}	≤ 1.7	V

ABSOLUTE MAXIMUM RATINGS:

Parameter	Symbol	Value	Unit
Storage junction temperature range	T_{stg}	-40~150	$^{\circ}C$
Operating junction temperature range	T_j	-40~125	$^{\circ}C$
Repetitive peak off-state voltage ($T_j=25^{\circ}C$)	V_{DRM}	600/800	V
Repetitive peak reverse voltage ($T_j=25^{\circ}C$)	V_{RRM}	600/800	V
RMS on-state current	$I_{T(RMS)}$	4	A



Jiangsu Weida Semiconductor Co., Ltd.

BT134 Series 4A Triacs

Non repetitive surge peak on-state current (full cycle, F=50Hz)		I_{TSM}	25	A
I^2t value for fusing ($t_p=10ms$)		I^2t	3.1	A^2s
Critical rate of rise of on-state current ($I_G=2 \times I_{GT}$)	di/dt	I - II - III	50	$A/\mu s$
		IV	10	
Peak gate current		I_{GM}	2	A
Average gate power dissipation		$P_{G(AV)}$	0.5	W
Peak gate power		P_{GM}	5	W

ELECTRICAL CHARACTERISTICS ($T_j=25^\circ C$ unless otherwise specified)

Parameter	Test Condition	Quadrant		Value			Unit
				T	D	E	
I_{GT}	$V_D=12V$, $R_L=33\Omega$	I - II - III	MAX	5	5	10	mA
		IV		5	10	25	
V_{GT}		I - II - III - IV		1.3			V
V_{GD}	$V_D=V_{DRM}$	I - II - III - IV	MIN	0.2			V
I_H			MAX	5	10	20	mA
I_L	$I_G=1.2I_{GT}$	I - III - IV	MAX	8	10	20	mA
		II		12	15	35	
dV/dt	$V_D=0.66 \times V_{DRM}$ $T_j=125^\circ C$ Gate open		MIN	10	20	50	$V/\mu s$

STATIC CHARACTERISTICS

Symbol	Test Condition			Value	Unit
V_{TM}	$I_{TM}=5A$ $t_p=380\mu s$	$T_j=25^\circ C$	MAX	1.7	V
I_{DRM} I_{RRM}	$V_{DRM}=V_{RRM}$	$T_j=25^\circ C$	MAX	5	μA
		$T_j=125^\circ C$		0.5	mA



Jiangsu Weida Semiconductor Co., Ltd.

BT134 Series 4A Triacs

THERMAL RESISTANCES

Symbol	Test Condition		Value	Unit
$R_{th(j-c)}$	junction to case(AC)	TO-252-4R	3.8	°C/W
		SOT-223	3.9	
		TO-220B(Non-Ins)/ TO-220C	3.2	
		TO-202-3	4.6	
		TO-126/SOT-82	4.2	
		TO-92	11.3	

ORDERING INFORMATION

BT Triacs $I_{T(RMS)}:4A$	134-600	D V_{DRM}, V_{RRM} : 600: 600V 800: 800V	$T: I_{GT1-3} \leq 5mA, I_{GT4} \leq 5mA$ $D: I_{GT1-3} \leq 5mA, I_{GT4} \leq 10mA$ $E: I_{GT1-3} \leq 10mA, I_{GT4} \leq 25mA$
--	----------------	--	--

PACKAGE MECHANICAL DATA

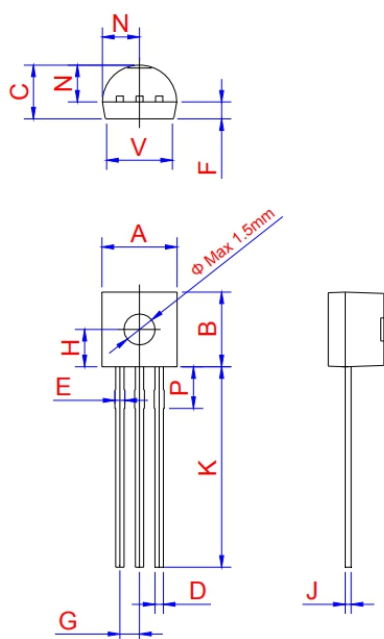

TO-92

Ref.	Dimensions					
	Millimeters			Inches		
	Min.	Typ.	Max.	Min.	Typ.	Max.
A	4.45	4.6	5.2	0.175	0.181	0.205
B	4.32	4.6	5.33	0.17	0.181	0.21
C	3.18	3.55	4.19	0.125	0.14	0.165
D	0.407		0.533	0.016		0.021
E	0.6		0.8	0.024	0	0.031
F	-	1.1	-	-	0.043	-
G	-	1.27	-	-	0.05	-
H	-	2.3	-	-	0.091	-
J	0.36	0.38	0.5	0.014	0.015	0.02
K	12.7		15	0.5		0.591
N	2.04	2.3	2.66	0.08	0.091	0.105
P	1.86		2.06	0.073		0.081
V	-		4.3	-		0.169



Jiangsu Weida Semiconductor Co., Ltd.
BT134 Series 4A Triacs

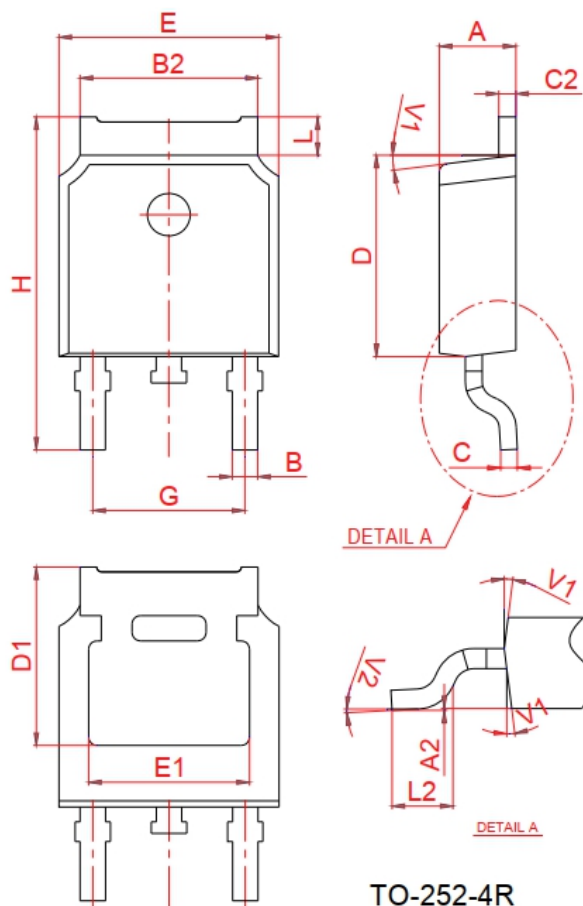

Ref.	Dimensions					
	Millimeters			Inches		
	Min.	Typ.	Max.	Min.	Typ.	Max.
A	2.2		2.4	0.087		0.094
A2	0		0.1	0		0.004
B	0.66		0.86	0.026		0.034
B2	5.1		5.46	0.201		0.215
C	0.46		0.58	0.018		0.023
C2	0.44		0.58	0.017		0.023
D	5.9		6.3	0.232		0.248
D1	5.30REF			0.211REF		
E	6.4		6.8	0.252		0.268
E1	4.63			0.182		
G	4.372		4.772	0.172		0.188
H	9.8		10.4	0.386		0.409
L	1.09		1.21	0.043		0.048
L2	1.35		1.65	0.053		0.065
V1		7°			7°	
V2	0°		6°	0°		6°

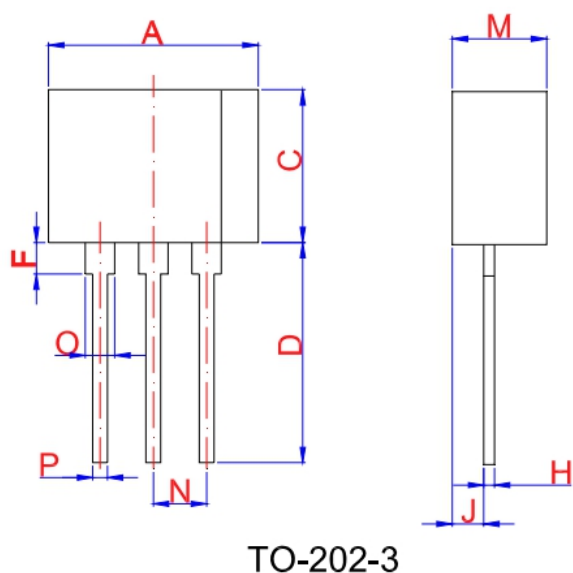

Ref.	Dimensions					
	Millimeters			Inches		
	Min.	Typ.	Max.	Min.	Typ.	Max.
A	9.30		9.90	0.366		0.39
C	7.00		7.60	0.276		0.299
D	10.5		11.50	0.413		0.453
F	1.50		2.50	0.059		0.098
H	0.45		0.55	0.018		0.022
J	1.50		1.90	0.059		0.075
M	4.40		4.70	0.173		0.185
N	2	2.54			0.100	
O	1.20		1.50	0.047		0.059
P	0.60		0.80	0.024		0.031



Jiangsu Weida Semiconductor Co., Ltd.
BT134 Series 4A Triacs

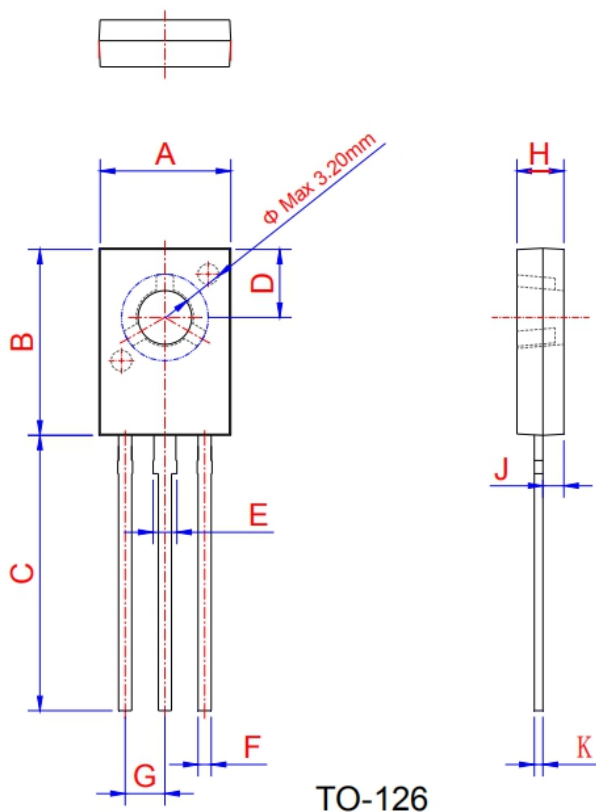

Ref.	Dimensions					
	Millimeters			Inches		
	Min.	Typ.	Max.	Min.	Typ.	Max.
A	7.4		7.8	0.291		0.307
B	10.6		11.2	0.417		0.441
C	15.3		16.3	0.602		0.642
D	3.9		4.1	0.154		0.161
E	1.17		1.47	0.046		0.058
F	0.66		0.86	0.026		0.034
G		2.29			0.09	
H	2.5		2.9	0.098		0.114
K	0.45		0.6	0.018		0.024

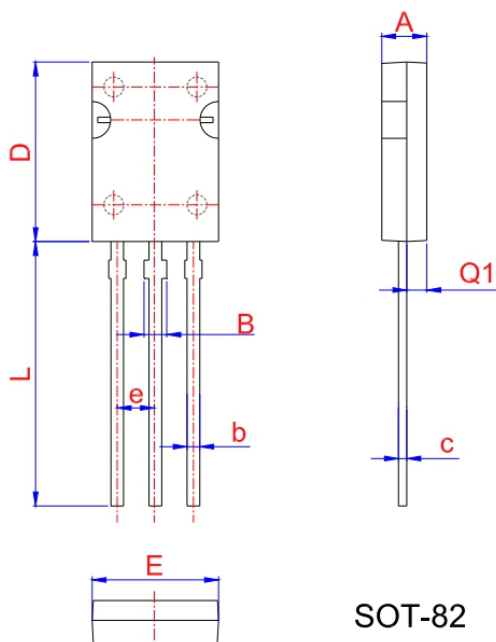

Ref.	Dimensions					
	Millimeters			Inches		
	Min.	Typ.	Max.	Min.	Typ.	Max.
A	2.45	2.55	2.65	0.096	0.100	0.104
b	0.71	0.76	0.81	0.028	0.030	0.032
B	1.27	1.37	1.45	0.050	0.054	0.057
c	0.48	0.50	0.52	0.019	0.020	0.021
D	10.60	10.80	11.00	0.417	0.425	0.433
E	7.30	7.5	7.70	0.287	0.295	0.303
e	2.24	2.29	2.34	0.088	0.090	0.092
L	15.30	15.60	15.90	0.602	0.614	0.626
Q1	1.17	1.27	1.37	0.046	0.050	0.054



Jiangsu Weida Semiconductor Co., Ltd.
BT134 Series 4A Triacs

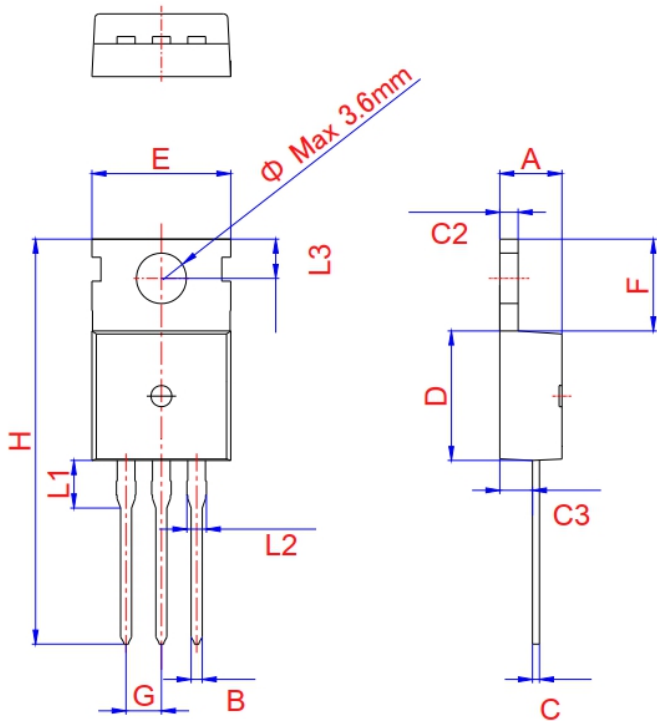

TO-220C

Ref.	Dimensions					
	Millimeters			Inches		
	Min.	Typ.	Max.	Min.	Typ.	Max.
A	4.3		4.5	0.169		0.177
B	0.7		0.9	0.028		0.035
C	0.45		0.6	0.018		0.024
C2	1.23	1.30	1.32	0.048	0.051	0.052
C3	2.2		2.6	0.087		0.102
D	8.9		9.9	0.35		0.39
E	9.9	10.1	10.3	0.39	0.398	0.406
F	6.3		6.9	0.248		0.272
G		2.54			0.1	
H	28		29.8	1.102		1.173
L1		3.39			0.133	
L2	1.14		1.7	0.045		0.067
L3	2.65		2.95	0.104		0.116
Φ		3.6			0.142	

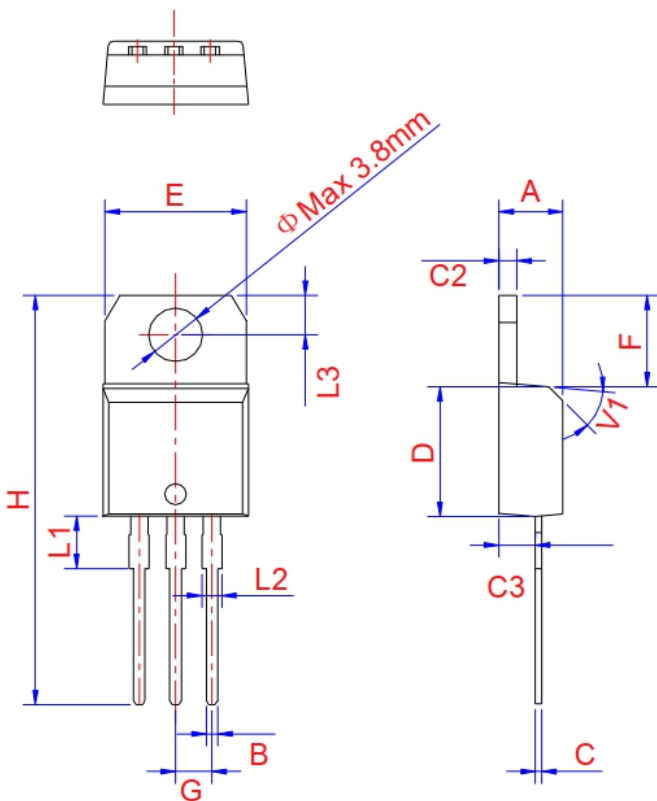

TO-220B Non-Ins

Ref.	Dimensions					
	Millimeters			Inches		
	Min.	Typ.	Max.	Min.	Typ.	Max.
A	4.4	4.47	4.6	0.173	0.176	0.181
B	0.61		0.88	0.024		0.035
C	0.46	0.50	0.7	0.018	0.02	0.028
C2	1.21	1.27	1.32	0.048	0.050	0.052
C3	2.4		2.72	0.094		0.107
D	8.6		9.7	0.339		0.382
E	9.8		10.4	0.386		0.409
F	6.55		6.95	0.258		0.274
G		2.54			0.1	
H	28		29.8	1.102		1.173
L1		3.75			0.148	
L2	1.14		1.7	0.045		0.067
L3	2.65		2.95	0.104		0.116
V1		45°			45°	



Jiangsu Weida Semiconductor Co., Ltd.
BT134 Series 4A Triacs

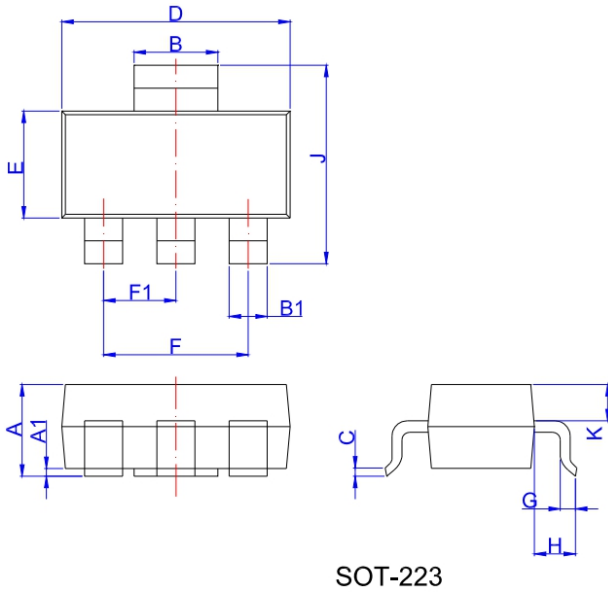

Ref.	Dimensions					
	Millimeters			Inches		
	Min.	Typ.	Max.	Min.	Typ.	Max.
A	1.5	1.6	1.8	0.059	0.063	0.071
A1	0.01	0.06	0.10	0.001	0.002	0.004
B	2.9	3.0	3.1	0.114	0.118	0.122
B1	0.6	0.7	0.8	0.024	0.028	0.031
C	0.22	0.25	0.32	0.009	0.010	0.013
D	6.3	6.5	6.7	0.248	0.256	0.264
E	3.3	3.5	3.7	0.130	0.138	0.146
F		4.6	6.8	0.252	0.181	
F1		2.3			0.091	
G	0.7	0.9	1.1	0.028	0.035	0.043
H	1.5	1.75	2.0	0.059	0.069	0.079
J	6.7	7.0	7.3	0.264	0.276	0.287
K	0.8	0.9	1.0	0.031	0.035	0.039

FIG.1: Maximum power dissipation versus RMS on-state current

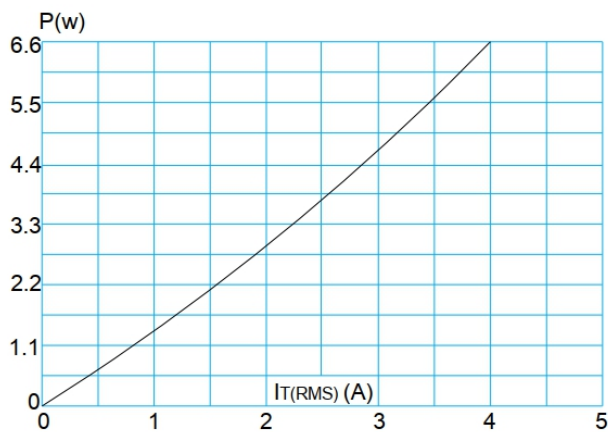
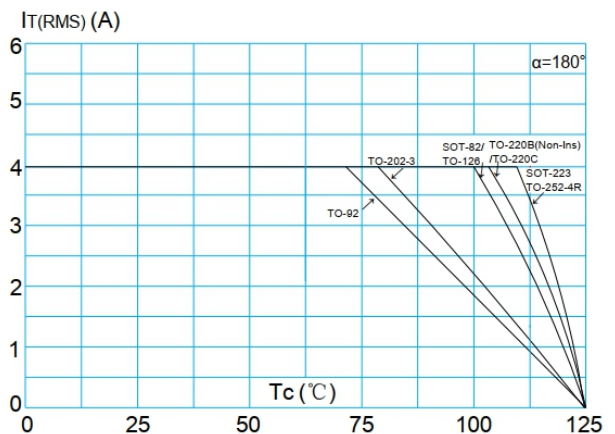

FIG.2: RMS on-state current versus case temperature





Jiangsu Weida Semiconductor Co., Ltd.

BT134 Series 4A Triacs

FIG.3: Surge peak on-state current versus number of cycles

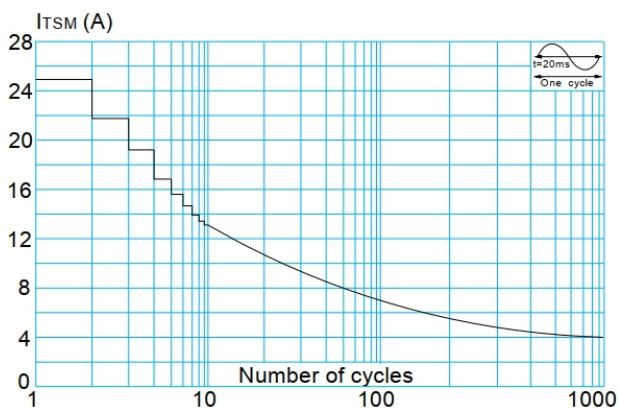

FIG.5: Non-repetitive surge peak on-state current for a sinusoidal pulse with width $t_p < 20ms$, and corresponding value of I^2t (I - II - III: $dI/dt < 50A/\mu s$; IV: $dI/dt < 10A/\mu s$)

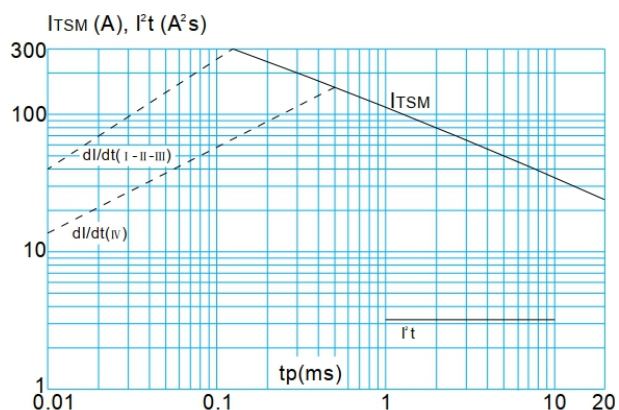

FIG.7: Relative variations of holding current versus junction temperature

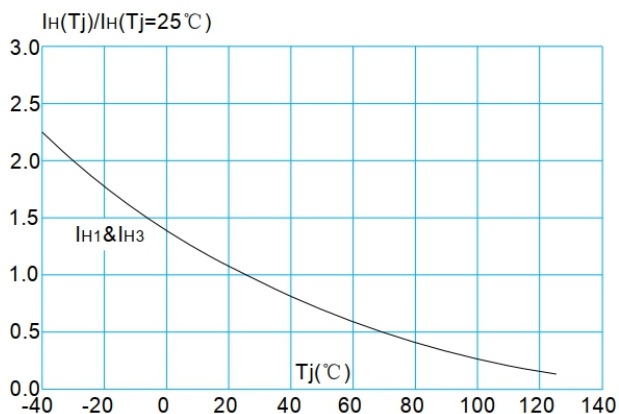

FIG.4: On-state characteristics (maximum values)

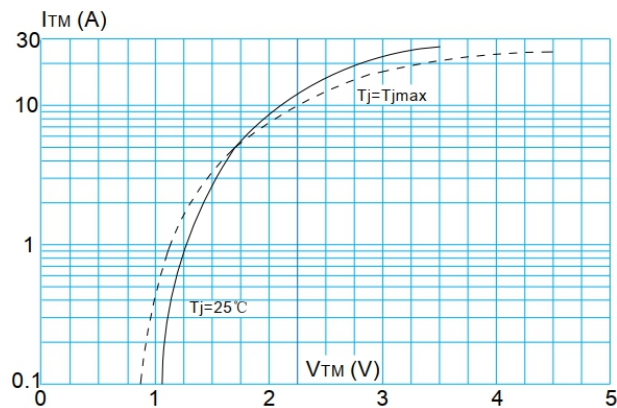

FIG.6: Relative variations of gate trigger current versus junction temperature

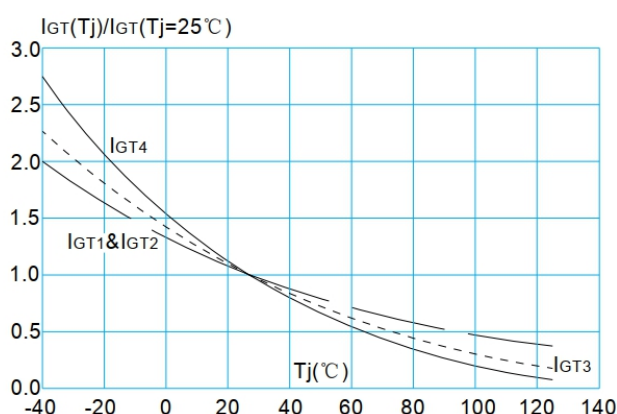
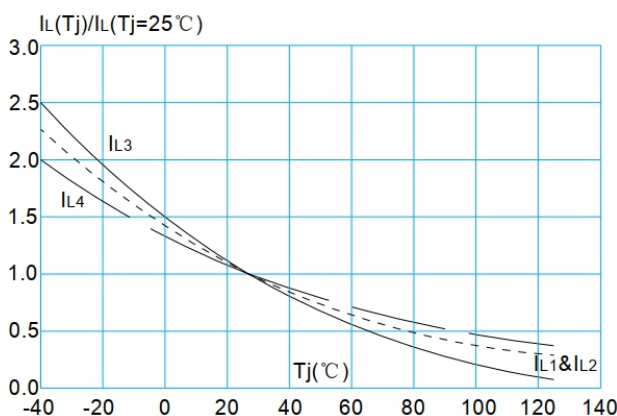

FIG.8: Relative variations of latching current versus junction temperature





Jiangsu Weida Semiconductor Co., Ltd.

BT134 Series 4A Triacs

Information furnished in this document is believed to be accurate and reliable. However, Jiangsu Weida Semiconductor Co., Ltd assumes no responsibility for the consequences of use without consideration for such information nor use beyond it.

Information mentioned in this document is subject to change without notice, apart from that when an agreement is signed, Jiangsu Weida Semiconductor Co., Ltd complies with the agreement.

Products and information provided in this document have no infringement of patents. Jiangsu Weida Semiconductor Co., Ltd assumes no responsibility for any infringement of other rights of third parties which may result from the use of such products and information.

X-ON Electronics

Largest Supplier of Electrical and Electronic Components

Click to view similar products for [Triacs](#) category:

Click to view products by [Weida Semiconductor](#) manufacturer:

Other Similar products are found below :

[BT137-600-0Q](#) [OT415Q](#) [2N6075A](#) [NTE5688](#) [BTA2008W-800D,135](#) [D31410](#) [ACS102-5T1](#) [ACS102-5TA](#) [MAC97A4G](#) [Z0107MAG](#)
[Z0107MARL1G](#) [Z0109MARLRPG](#) [MAC97A8-TA](#) [BT131W-800](#) [BT138S-800E](#) [BT137S-800E](#) [BT136S-600D](#) [BTA08-600TWRG](#)
[X0405MF-252](#) [MAC97A8-23-3L](#) [MCR100-8-23-3L](#) [BTA24-800B](#) [BT151-600R](#) [BT131](#) [BTA41-1200B](#) [MCR16](#) [MCR100-8](#) [MCR16](#)
[BT131-800D](#) [BT134-800E](#) [BT138-800E](#) [MCR100-8](#) [BTA12-800BWRG\(UMW\)](#) [BTA24-600BWRG\(UMW\)](#) [BTA24-800BWRG\(UMW\)](#)
[BTA12-600BWRG\(UMW\)](#) [BTA16-600CRG\(UMW\)](#) [BTA12-600CRG\(UMW\)](#) [BS61089B-8](#) [BT134W-600E](#) [BT134-600E](#) [JR0405S3](#)
[BCR12PM](#) [MAC97A6](#) [MAC4DLM-1G](#) [BT137-600E,127](#) [BTA08-800BW3G](#) [BTA140-800,127](#) [BTA30-600CW3G](#) [BTA30-600CW3G](#)