



Jiangsu Weida Semiconductor Co., Ltd.

BT151 Series 12A Triacs

DESCRIPTION:

With high ability to withstand the shock loading of large current, BT151 series of silicon controlled rectifiers provide high dv/dt rate with strong resistance to electromagnetic interference.

They are especially recommended for use on solid state relay, motorcycle, power charger, T-tools etc.

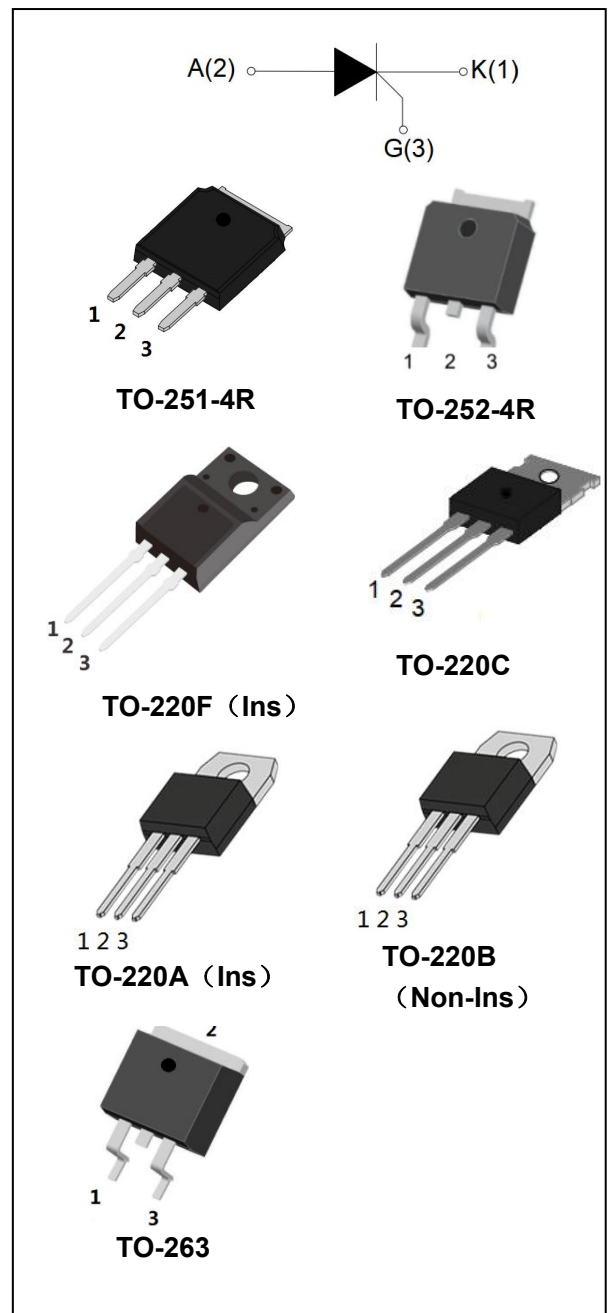

MAIN FEATURES:

symbol	value	unit
$I_{T(RMS)}$	12	A
V_{DRM}/V_{RRM}	650	V
I_{GT}	15	mA

ABSOLUTE MAXIMUM RATINGS:

Parameter	Symbol	Value	Unit
Storage junction temperature range	T_{stg}	-40~150	°C
Operating junction temperature range	T_j	-40~125	°C
Repetitive peak off-state voltage ($T_j=25^\circ\text{C}$)	V_{DRM}	650	V
Repetitive peak reverse voltage ($T_j=25^\circ\text{C}$)	V_{RRM}	650	V



Jiangsu Weida Semiconductor Co., Ltd.

BT151 Series 12A Triacs

RMS on-state current	$I_{T(RMS)}$	12	A
Non repetitive surge peak on-state current (full cycle, F=50Hz)	I_{TSM}	120	A
I^2t value for fusing ($t_p=10ms$)	I^2t	72	A^2s
Critical rate of rise of on-state current($I_G=2 \times I_{GT}$)	di/dt	50	$A/\mu s$
Peak gate current	I_{GM}	2	A
Average gate power dissipation	$P_{G(AV)}$	0.5	W
Peak gate power	P_{GM}	5	W

ELECTRICAL CHARACTERISTICS ($T_j=25^\circ C$ unless otherwise specified)

Parameter	Test Condition	MIN	TYPE	MAX	Unit
I_{GT}	$V_D=12V, R_L=33\Omega$	-	4	15	mA
V_{GT}		-	0.75	1.5	V
V_{GD}	$V_D=V_{DRM} T_j=110^\circ C$	0.2	-	-	V
I_H	$I_T=50mA$	-	-	30	mA
I_L	$I_G=1.2I_{GT}$	-	-	40	mA
dV/dt	$V_D=2/3 \times V_{DRM} T_j=125^\circ C$ Gate open	200	-	-	$V/\mu s$

STATIC CHARACTERISTICS

Symbol	Test Condition			Value	Unit	
V_{TM}	$I_{TM}=23A$	$t_p=380\mu s$	$T_j=25^\circ C$	MAX	1.75	V
I_{DRM} I_{RRM}	$V_D=V_{DRM}=V_{RRM}$		$T_j=25^\circ C$	MAX	5	μA
			$T_j=110^\circ C$		0.5	mA



Jiangsu Weida Semiconductor Co., Ltd.

BT151 Series 12A Triacs

THERMAL RESISTANCES

Symbol	Test Condition	Value	Unit	
$R_{th(j-c)}$	junction to case(AC)	TO-251-4R/TO-252-4R	1.4	°C/W
		TO-220B(Non-Ins)/TO-220C	1.3	
		TO-220F	1.6	
		TO-263	1.1	
		TO-220A(Ins)	1.5	

ORDERING INFORMATION

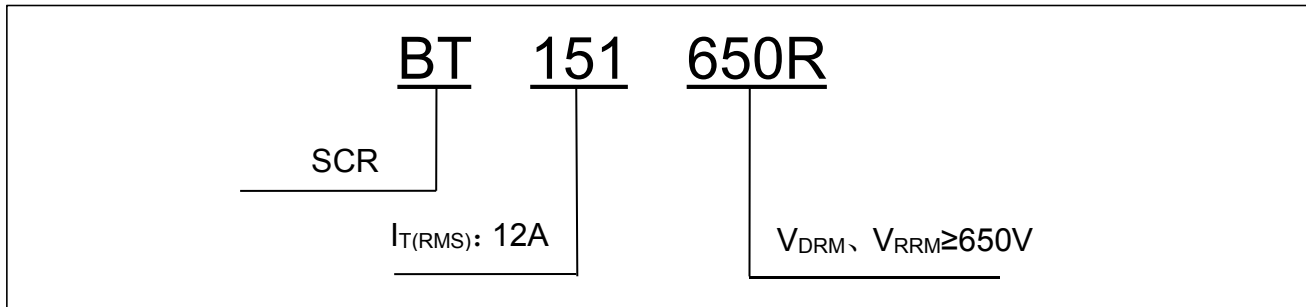

PACKAGE MECHANICAL DATA

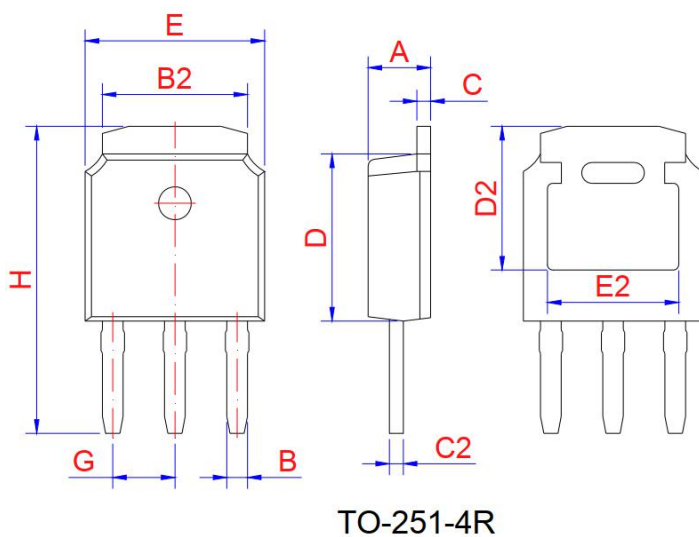

Ref.	Dimensions					
	Millimeters			Inches		
	Min.	Typ.	Max.	Min.	Typ.	Max.
A	2.10	2.30	2.50	0.083	0.091	0.098
B	0.66	0.76	0.86	0.026	0.030	0.034
B2	5.15	5.33	5.48	0.203	0.210	0.216
C	0.44	0.51	0.58	0.017	0.020	0.023
C2	0.44	0.51	0.58	0.017	0.020	0.023
D	5.90	6.10	6.30	0.232	0.240	0.248
D2	5.30REF			0.209REF		
E	6.40	6.60	6.80	0.252	0.260	0.268
E2	4.83REF			0.190REF		
G	2.19	2.29	2.39	0.086	0.090	0.094
H	10.60	11.20	11.80	0.417	0.441	0.465



Jiangsu Weida Semiconductor Co., Ltd.

BT151 Series 12A Triacs

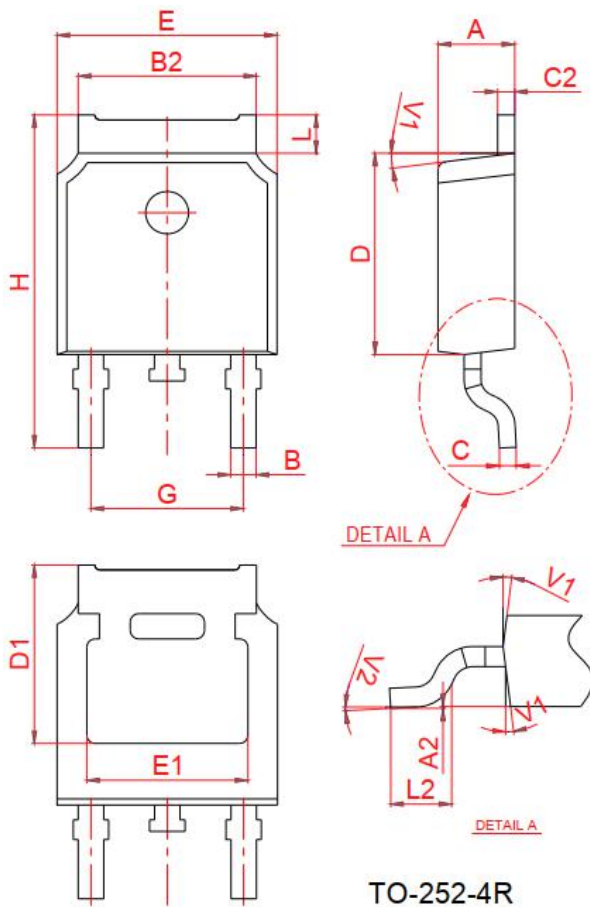

Ref.	Dimensions					
	Millimeters			Inches		
	Min.	Typ.	Max.	Min.	Typ.	Max.
A	2.2		2.4	0.087		0.094
A2	0		0.1	0		0.004
B	0.66		0.86	0.026		0.034
B2	5.1		5.46	0.201		0.215
C	0.46		0.58	0.018		0.023
C2	0.44		0.58	0.017		0.023
D	5.9		6.3	0.232		0.248
D1	5.30REF			0.211REF		
E	6.4		6.8	0.252		0.268
E1	4.63			0.182		
G	4.372		4.772	0.172		0.188
H	9.8		10.4	0.386		0.409
L	1.09		1.21	0.043		0.048
L2	1.35		1.65	0.053		0.065
V1		7°			7°	
V2	0°		6°	0°		6°

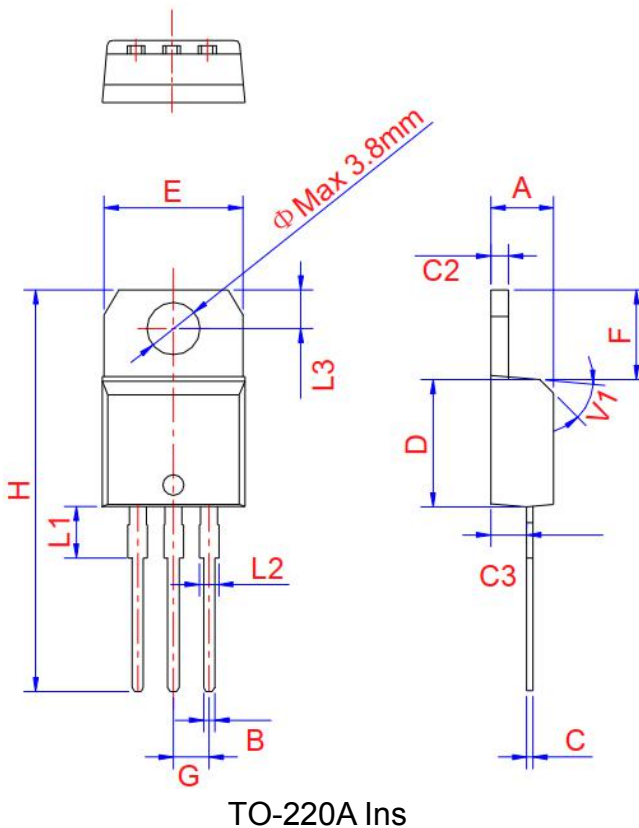

Ref.	Dimensions					
	Millimeters			Inches		
	Min.	Typ.	Max.	Min.	Typ.	Max.
A	4.4	4.47	4.6	0.173	0.176	0.181
B	0.61		0.88	0.024		0.035
C	0.46	0.50	0.7	0.018	0.02	0.028
C2	1.21	1.27	1.32	0.048	0.050	0.052
C3	2.4		2.72	0.094		0.107
D	8.6		9.7	0.339		0.382
E	9.8		10.4	0.386		0.409
F	6.55		6.95	0.258		0.274
G		2.54			0.1	
H	28		29.8	1.102		1.173
L1		3.75			0.148	
L2	1.14		1.7	0.045		0.067
L3	2.65		2.95	0.104		0.116
V1		45°			45°	



Jiangsu Weida Semiconductor Co., Ltd.

BT151 Series 12A Triacs

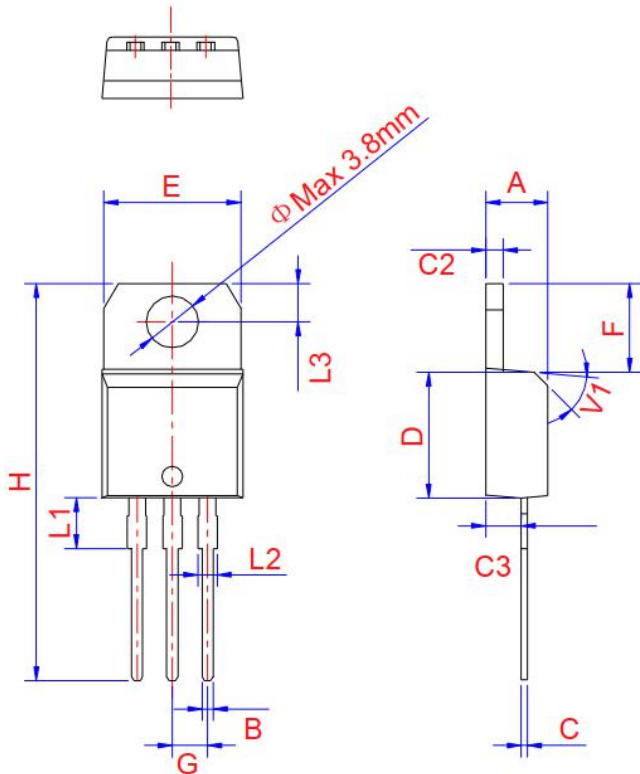

TO-220B Non-Ins

Ref.	Dimensions					
	Millimeters			Inches		
	Min.	Typ.	Max.	Min.	Typ.	Max.
A	4.4	4.47	4.6	0.173	0.176	0.181
B	0.61		0.88	0.024		0.035
C	0.46	0.50	0.7	0.018	0.02	0.028
C2	1.21	1.27	1.32	0.048	0.050	0.052
C3	2.4		2.72	0.094		0.107
D	8.6		9.7	0.339		0.382
E	9.8		10.4	0.386		0.409
F	6.55		6.95	0.258		0.274
G		2.54			0.1	
H	28		29.8	1.102		1.173
L1		3.75			0.148	
L2	1.14		1.7	0.045		0.067
L3	2.65		2.95	0.104		0.116
V1		45°			45°	

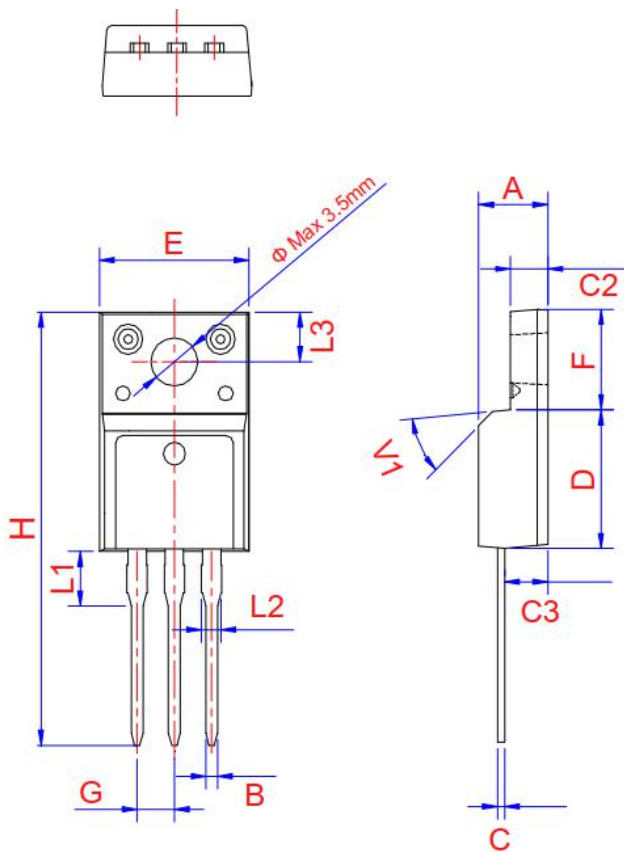

TO-220F Ins

Ref.	Dimensions					
	Millimeters			Inches		
	Min.	Typ.	Max.	Min.	Typ.	Max.
A	4.5		4.9	0.177		0.193
B	0.74	0.8	0.83	0.029	0.031	0.033
C	0.47		0.65	0.019		0.026
C2	2.45		2.75	0.096		0.108
C3	2.6		3	0.102		0.118
D	8.8		9.3	0.346		0.366
E	9.8		10.4	0.386		0.41
F	6.4		6.8	0.252		0.268
G		2.54			0.1	
H	28		29.8	1.102		1.173
L1		3.63			0.148	
L2	1.14		1.7	0.045		0.067
L3	2.65	3.3	0		0.13	0.116
V1		45°			45°	



Jiangsu Weida Semiconductor Co., Ltd.

BT151 Series 12A Triacs

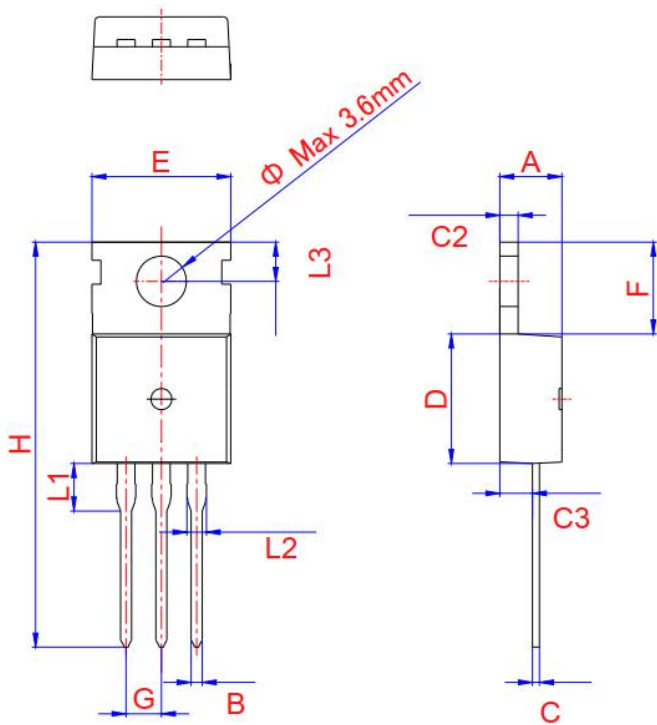

TO-220C

Ref.	Dimensions					
	Millimeters			Inches		
	Min.	Typ.	Max.	Min.	Typ.	Max.
A	4.3		4.5	0.169		0.177
B	0.7		0.9	0.028		0.035
C	0.45		0.6	0.018		0.024
C2	1.23	1.30	1.32	0.048	0.051	0.052
C3	2.2		2.6	0.087		0.102
D	8.9		9.9	0.35		0.39
E	9.9	10.1	10.3	0.39	0.398	0.406
F	6.3		6.9	0.248		0.272
G		2.54			0.1	
H	28		29.8	1.102		1.173
L1		3.39			0.133	
L2	1.14		1.7	0.045		0.067
L3	2.65		2.95	0.104		0.116
Φ		3.6			0.142	

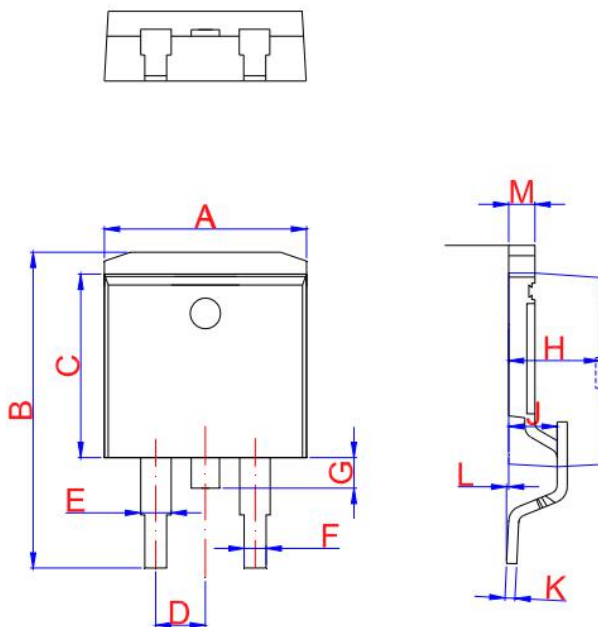

TO-263

Ref.	Dimensions					
	Millimeters			Inches		
	Min.	Typ.	Max.	Min.	Typ.	Max.
A	9.9		10.3	0.390		0.406
B	14.7		15.8	0.579		0.622
C	8.5		8.9	0.370		0.378
D		2.54			0.100	
E	1.20		1.40	0.047		0.055
F	0.75		0.85	0.029		0.033
G			1.75			0.069
H	4.40	4.60	4.80	0.173	0.181	0.189
J	2.40	2.60	2.80	0.094	0.102	0.110
L	0	0.1	0.25	0	0.004	0.010
M	1.17	1.27	1.37	0.046	0.05	0.054



Jiangsu Weida Semiconductor Co., Ltd.
BT151 Series 12A Triacs

FIG.1: Maximum power dissipation versus RMS on-state current

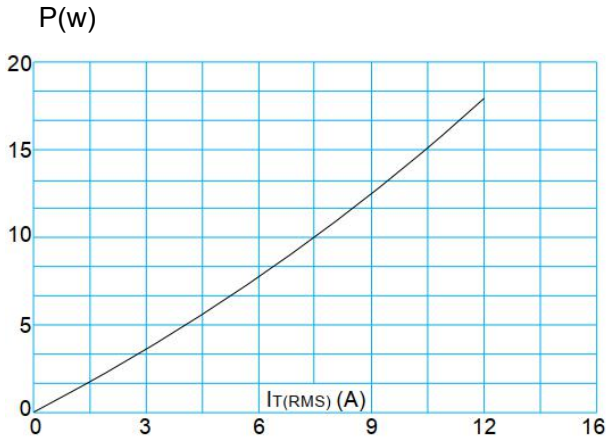

FIG.3: Surge peak on-state current versus number of cycles

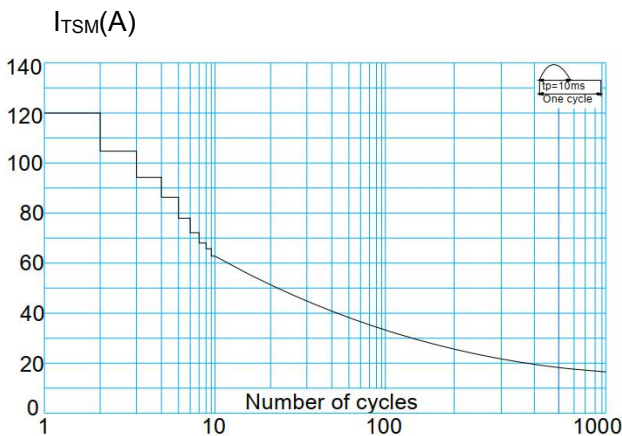

FIG.5: Non-repetitive surge peak on-state current for a sinusoidal pulse with width $t_p < 20\text{ms}$, and corresponding value of I^2t (I - II -III: $dI/dt < 50\text{A}/\mu\text{s}$; IV: $dI/dt < 10\text{A}/\mu\text{s}$)

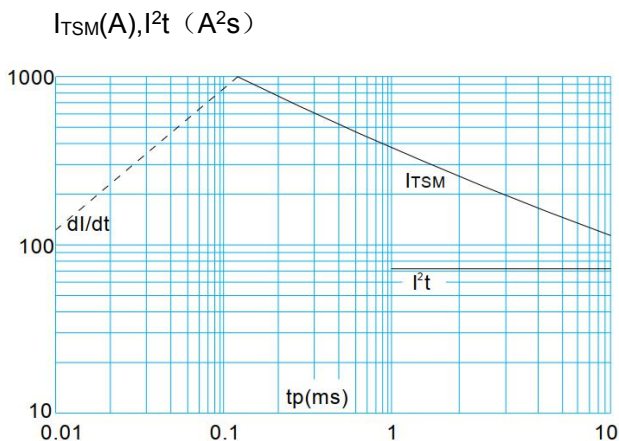

FIG.2: RMS on-state current versus case temperature

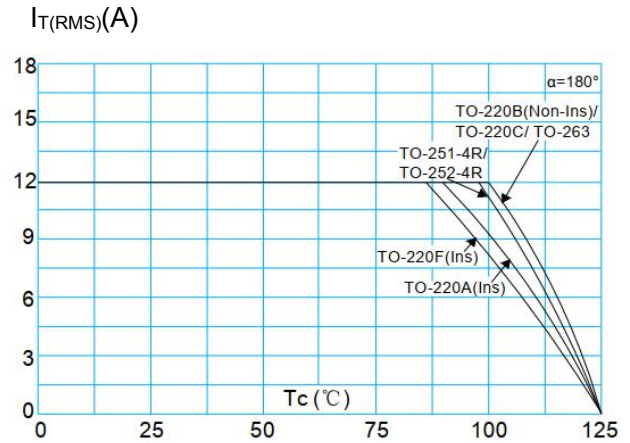

FIG.4: On-state characteristics (maximum values)

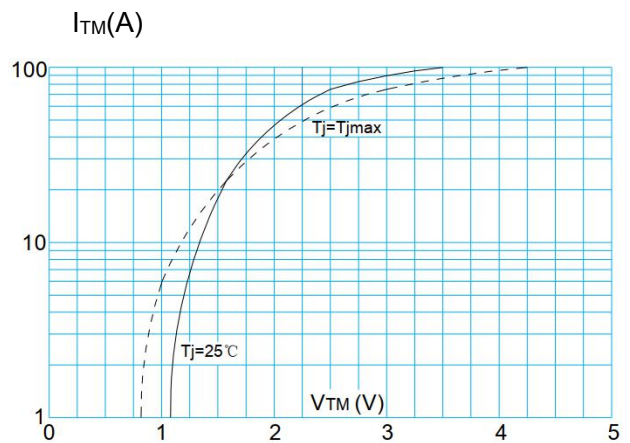
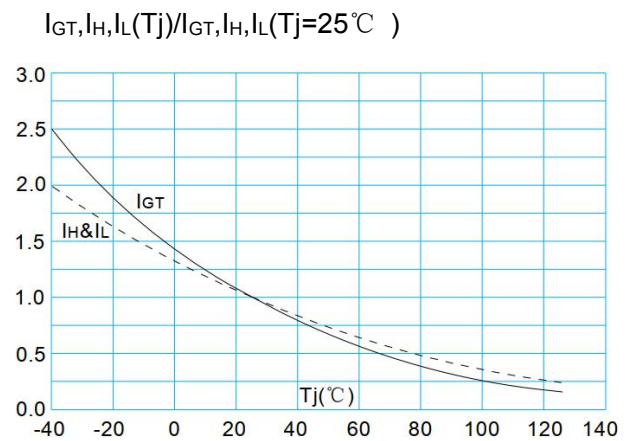

FIG.6: Relative variations of gate trigger current, holding current and latching current versus junction temperature





Jiangsu Weida Semiconductor Co., Ltd.
BT151 Series 12A Triacs

Information furnished in this document is believed to be accurate and reliable. However, Jiangsu Weida Semiconductor Co., Ltd assumes no responsibility for the consequences of use without consideration for such information nor use beyond it.

Information mentioned in this document is subject to change without notice, apart from that when an agreement is signed, Jiangsu Weida Semiconductor Co., Ltd complies with the agreement.

Products and information provided in this document have no infringement of patents. Jiangsu Weida Semiconductor Co., Ltd assumes no responsibility for any infringement of other rights of third parties which may result from the use of such products and information.

X-ON Electronics

Largest Supplier of Electrical and Electronic Components

Click to view similar products for [Triacs](#) category:

Click to view products by [Weida Semiconductor](#) manufacturer:

Other Similar products are found below :

[BT137-600-0Q](#) [OT415Q](#) [2N6075A](#) [NTE5688](#) [BTA2008W-800D,135](#) [D31410](#) [QJ8006NH4TP](#) [QJ8010NH5TP](#) [QJ8008NH4TP](#)
[QJ8006NH4RP](#) [QJ8010RH5TP](#) [QJ8010NH4TP](#) [QJ8006LH4TP](#) [BT136-600,127](#) [BT137B-800,118](#) [BT138-800E,127](#) [BTA140-600,127](#)
[BTA208-800B,127](#) [BTA225-800B,127](#) [MAC97A6,116](#) [BTA420-800BT,127](#) [BTA201W-800E,115](#) [BTA212B-800B,118](#) [MCR100-8](#) [100-8](#)
[BT131S](#) [MCR100-6](#) [MCR100-8](#) [BT136S-800E](#) [BT134S-600E](#) [BT151-650R](#) [BT136-800E](#) [BTA12-800B](#) [BT138S-800E](#) [MAC97A8](#)
[BT137S-800E](#) [BT169-23](#) [BT131-89-2L](#) [MAC97A6-23-3L](#) [BT169-89-2L](#) [BT139-800E](#) [MCR100-8](#) [BT169-MS](#) [MCR100-8](#) [MCR100-6](#)
[BTA408X-1000C0T,127](#) [ACT108-800EQP](#) [BTA201-800ER,116](#) [T810](#) [2P4M](#) [BT137-600E](#)