

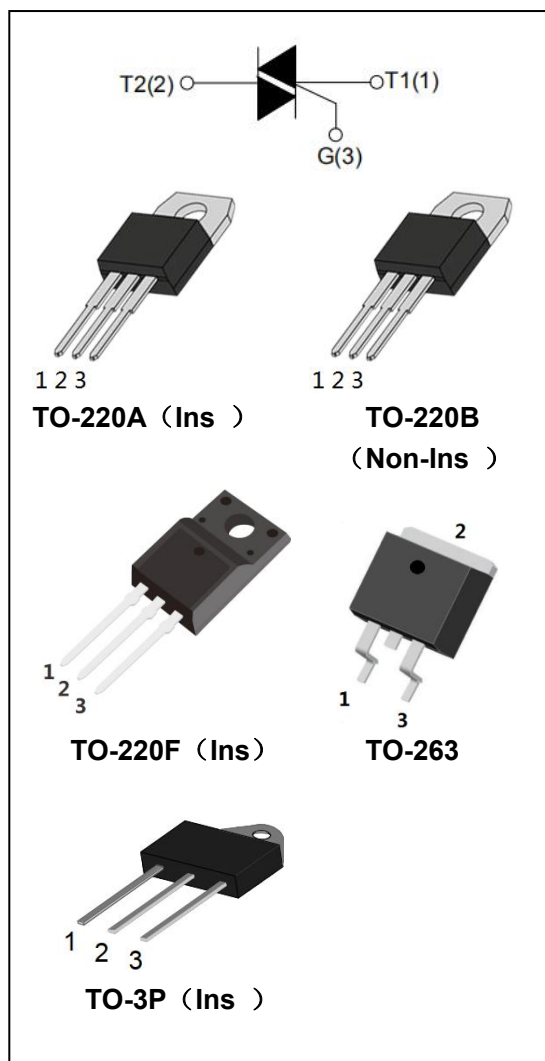

DESCRIPTION:

With high ability to withstand the shock loading of Large current, BTA26/BTB26 series triacs provide high dv/dt rate with strong resistance to electromagnetic interface. With high commutation performances, 3 quadrants products especially recommended for use on inductive load. From all three terminals to external heatsink, BTA26 provides a rated insulation voltage of 2500 V_{RMS} complying with UL standards (File ref: E516503).



MAIN FEATURES:

symbol	value	unit
$I_{T(RMS)}$	25	A
V_{DRM}/V_{RRM}	600/800/1200/1600	V
V_{TM}	≤ 1.5	V

ABSOLUTE MAXIMUM RATINGS:

Parameter	Symbol	Value	Unit
Storage junction temperature range	T_{stg}	-40~150	$^{\circ}C$
Operating junction temperature range	T_j	-40~125	$^{\circ}C$
Repetitive peak off-state voltage ($T_j=25^{\circ}C$)	V_{DRM}	600/800/1200	V
Repetitive peak reverse voltage ($T_j=25^{\circ}C$)	V_{RRM}	600/800/1200	V
RMS on-state current	$I_{T(RMS)}$	25	A
Non repetitive surge peak on-state current (full cycle, F=50Hz)	I_{TSM}	250	A
I^2t value for fusing ($t_p=10ms$)	I^2t	340	A^2s
Critical rate of rise of on-state current($I_G=2 \times I_{GT}$)	di/dt	50	$A/\mu s$



Jiangsu Weida Semiconductor Co., Ltd.

BTA26/BTB26 Series 25A Triacs

Peak gate current	I_{GM}	4	A
Average gate power dissipation	$P_{G(AV)}$	1	W
Peak gate power	P_{GM}	10	W

ELECTRICAL CHARACTERISTICS ($T_j=25^\circ\text{C}$ unless otherwise specified)

3 Quadrants:

Parameter	Test Condition	Quadrant		Value		Unit
				CW	BW	
I_{GT}	$V_D=12\text{V}$, $R_L=33\Omega$	I - II -III	MAX	35	50	mA
V_{GT}				1.3		V
V_{GD}	$V_D=V_{DRM}$	I - II -III	MIN	0.2		V
I_H	$I_T=100\text{mA}$		MAX	60	80	mA
I_L	$I_G=1.2I_{GT}$	I -III	MAX	70	90	mA
		II		80	100	
dV/dt	$V_D=2/3V_{DRM}$ $T_j=125^\circ\text{C}$ Gate open		MIN	1000	1500	V/ μs

4 Quadrants:

Parameter	Test Condition	Quadrant		Value		Unit
				C	B	
I_{GT}	$V_D=12\text{V}$, $R_L=33\Omega$	I - II -III	MAX	25	50	mA
		IV		50	70	mA
V_{GT}		ALL		1.5		V
V_{GD}	$V_D=V_{DRM}$	ALL	MIN	0.2		V
I_H	$I_T=100\text{mA}$		MAX	60	75	mA
I_L	$I_G=1.2I_{GT}$	I -III-IV	MAX	70	80	mA
		II		90	100	
dV/dt	$V_D=2/3V_{DRM}$ $T_j=125^\circ\text{C}$ Gate open		MIN	200	500	V/ μs



Jiangsu Weida Semiconductor Co., Ltd.

BTA26/BTB26 Series 25A Triacs

STATIC CHARACTERISTICS

Symbol	Test Condition			Value	Unit
V_{TM}	$I_{TM}=35A$ $t_p=380\mu s$	$T_j=25^\circ C$	MAX	1.5	V
I_{DRM} I_{RRM}	$V_{DRM}=V_{RRM}$	$T_j=25^\circ C$	MAX	10	μA
		$T_j=125^\circ C$		3	mA

THERMAL RESISTANCES

Symbol	Test Condition		Value	Unit
$R_{th(j-c)}$	junction to case(AC)	TO-220A(Ins)	1.5	$^\circ C/W$
		TO-220F(Ins)	1.6	
		TO-263	2.1	
		TO-3P(Ins)	1.0	

ORDERING INFORMATION

<p>B T A</p> <p>Triacs</p> <p>A: Insulated</p> <p>B: Non-Insulated</p>	<p>26 - 800</p> <p>$I_{T(RMS)}: 25A$</p>	<p>C W</p> <p>V_{DRM}, V_{RRM}:</p> <p>600: 600V</p> <p>800: 800V</p> <p>1200: 1200V</p> <p>1600: 1600V</p>	<p>B: $I_{GT1-3} \leq 50mA, I_{GT4} \leq 100mA$</p> <p>C: $I_{GT1-3} \leq 25mA, I_{GT4} \leq 50mA$</p> <p>CW: $I_{GT1-3} \leq 35mA$</p> <p>BW: $I_{GT1-3} \leq 50mA$</p>
---	--	---	--



Jiangsu Weida Semiconductor Co., Ltd.

BTA26/BTB26 Series 25A Triacs

PACKAGE MECHANICAL DATA

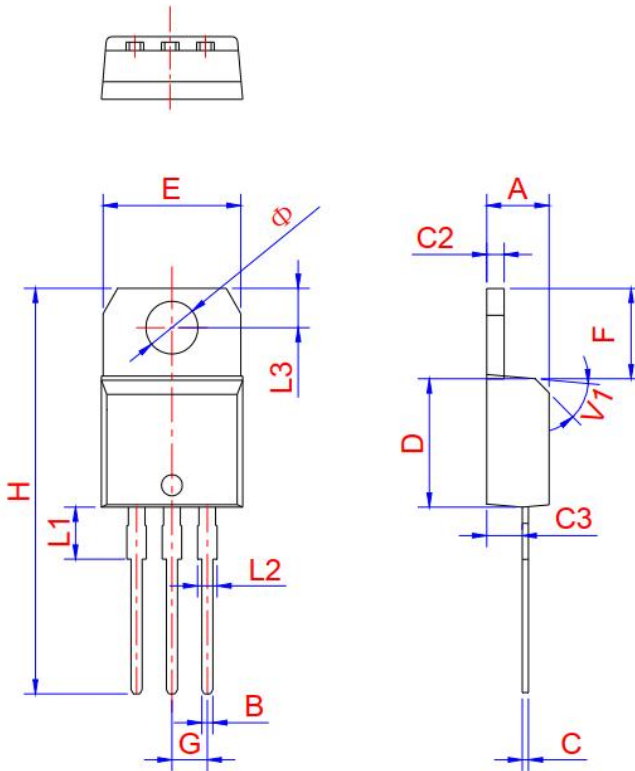

TO-220A Ins

Ref.	Dimensions					
	Millimeters			Inches		
	Min.	Typ.	Max.	Min.	Typ.	Max.
A	4.4	4.47	4.6	0.173	0.176	0.181
B	0.61		0.88	0.024		0.035
C	0.46	0.50	0.7	0.018	0.02	0.028
C2	1.21	1.27	1.32	0.048	0.050	0.052
C3	2.4		2.72	0.094		0.107
D	8.6		9.7	0.339		0.382
E	9.8		10.4	0.386		0.409
F	6.55		6.95	0.258		0.274
G		2.54			0.1	
H	28		29.8	1.102		1.173
L1		3.75			0.148	
L2	1.14		1.7	0.045		0.067
L3	2.65		2.95	0.104		0.116
V1		45°			45°	
Φ	3.7	3.75	3.8	0.145	0.147	0.149

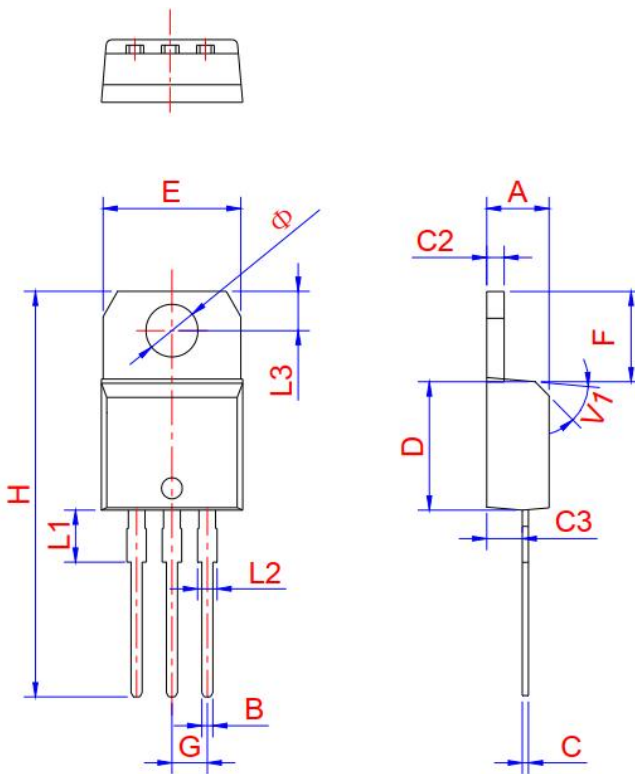

TO-220B Non-Ins

Ref.	Dimensions					
	Millimeters			Inches		
	Min.	Typ.	Max.	Min.	Typ.	Max.
A	4.4	4.47	4.6	0.173	0.176	0.181
B	0.61		0.88	0.024		0.035
C	0.46	0.50	0.7	0.018	0.02	0.028
C2	1.21	1.27	1.32	0.048	0.050	0.052
C3	2.4		2.72	0.094		0.107
D	8.6		9.7	0.339		0.382
E	9.8		10.4	0.386		0.409
F	6.55		6.95	0.258		0.274
G		2.54			0.1	
H	28		29.8	1.102		1.173
L1		3.75			0.148	
L2	1.14		1.7	0.045		0.067
L3	2.65		2.95	0.104		0.116
V1		45°			45°	
Φ	3.7	3.75	3.8	0.145	0.147	0.149



Jiangsu Weida Semiconductor Co., Ltd.
BTA26/BTB26 Series 25A Triacs

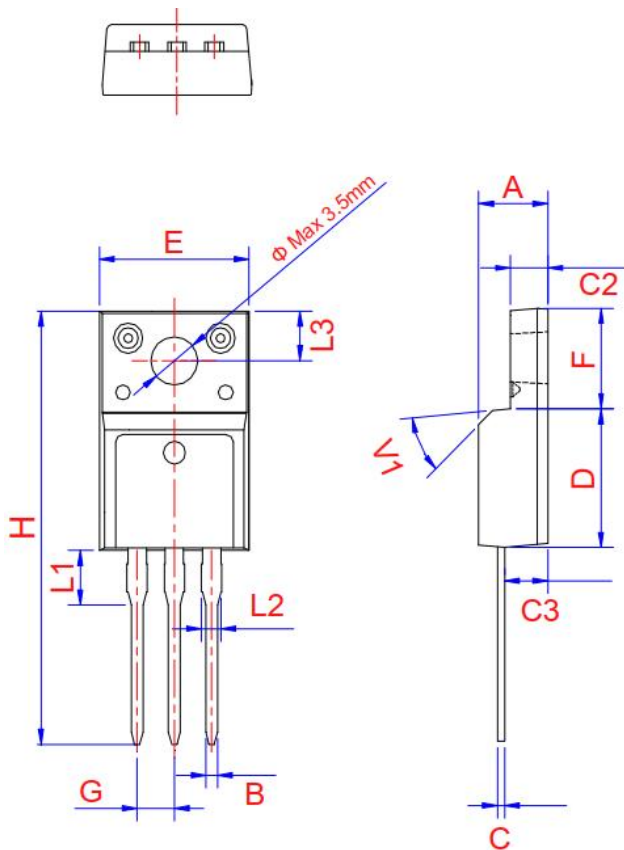

TO-220F Ins

Ref.	Dimensions					
	Millimeters			Inches		
	Min.	Typ.	Max.	Min.	Typ.	Max.
A	4.5		4.9	0.177		0.193
B	0.74	0.8	0.83	0.029	0.031	0.033
C	0.47		0.65	0.019		0.026
C2	2.45		2.75	0.096		0.108
C3	2.6		3	0.102		0.118
D	8.8		9.3	0.346		0.366
E	9.8		10.4	0.386		0.41
F	6.4		6.8	0.252		0.268
G		2.54			0.1	
H	28		29.8	1.102		1.173
L1		3.63			0.148	
L2	1.14		1.7	0.045		0.067
L3	2.65	3.3	0		0.13	0.116
V1		45°			45°	

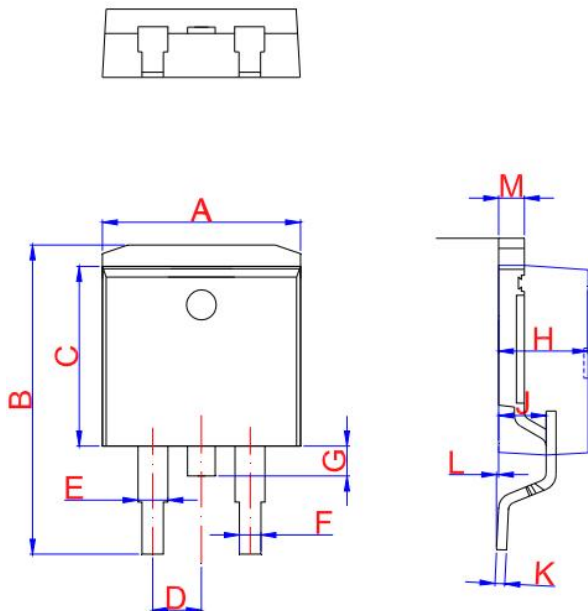

TO-263

Ref.	Dimensions					
	Millimeters			Inches		
	Min.	Typ.	Max.	Min.	Typ.	Max.
A	9.9		10.3	0.390		0.406
B	14.7		15.8	0.579		0.622
C	8.5		8.9	0.370		0.378
D		2.54			0.100	
E	1.20		1.40	0.047		0.055
F	0.75		0.85	0.029		0.033
G			1.75			0.069
H	4.40	4.60	4.80	0.173	0.181	0.189
J	2.40	2.60	2.80	0.094	0.102	0.110
L	0	0.1	0.25	0	0.004	0.010
M	1.17	1.27	1.37	0.046	0.05	0.054



Jiangsu Weida Semiconductor Co., Ltd.
BTA26/BTB26 Series 25A Triacs

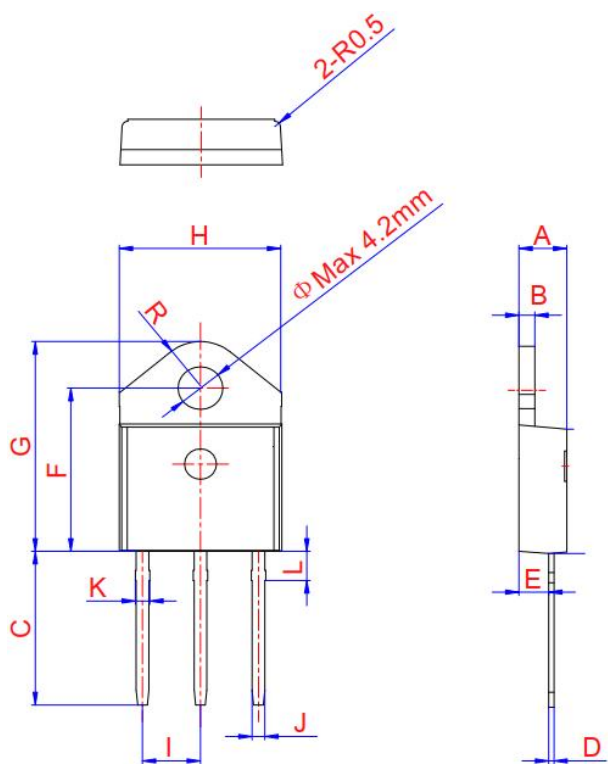

TO-3P Ins

Ref.	Dimensions					
	Millimeters			Inches		
	Min.	Typ.	Max.	Min.	Typ.	Max.
A	4.40	4.50	4.60	0.173	0.177	0.181
B	1.45	1.50	1.55	0.057	0.059	0.061
C	14.35		15.60	0.565		0.614
D	0.50	0.60	0.70	0.02	0.024	0.028
E	2.70	2.80	2.90	0.106	0.110	0.114
F	15.80		16.50	0.622		0.650
G	20.40		21.10	0.803		0.831
H	15.10	15.30	15.50	0.594	0.602	0.610
I	5.40		5.65	0.213		0.222
J	1.10		1.40	0.043		0.055
K	1.35		1.50	0.053		0.059
L	2.80	2.90	3.00	0.110	0.114	0.118
R		4.35			0.171	



Jiangsu Weida Semiconductor Co., Ltd.

BTA26/BTB26 Series 25A Triacs

FIG.1: Maximum power dissipation versus RMS on-state current

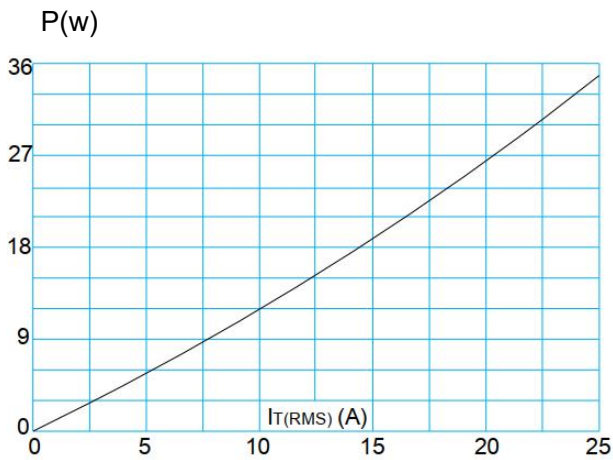

FIG.3: Surge peak on-state current versus number of cycles

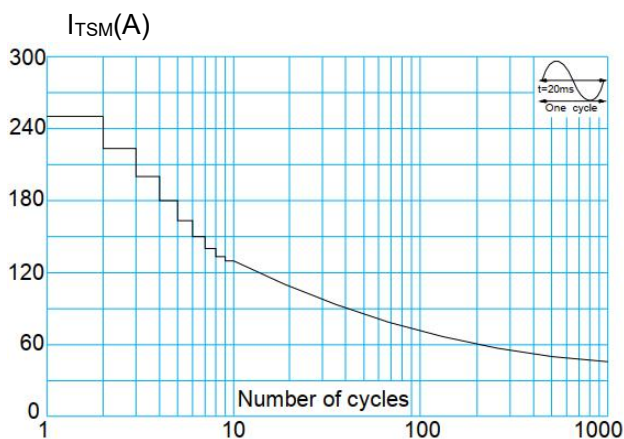

FIG.5: Non-repetitive surge peak on-state current for a sinusoidal pulse with width $t_p < 20\text{ms}$, and corresponding value of I^2t (I - II - III: $dI/dt < 50\text{A}/\mu\text{s}$; IV: $dI/dt < 10\text{A}/\mu\text{s}$)

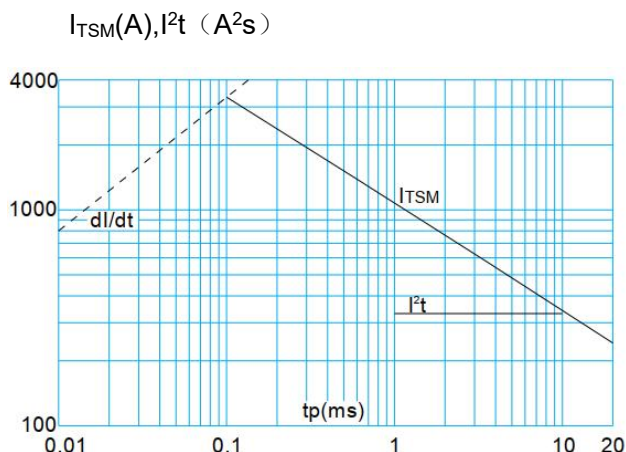

FIG.2: RMS on-state current versus case temperature

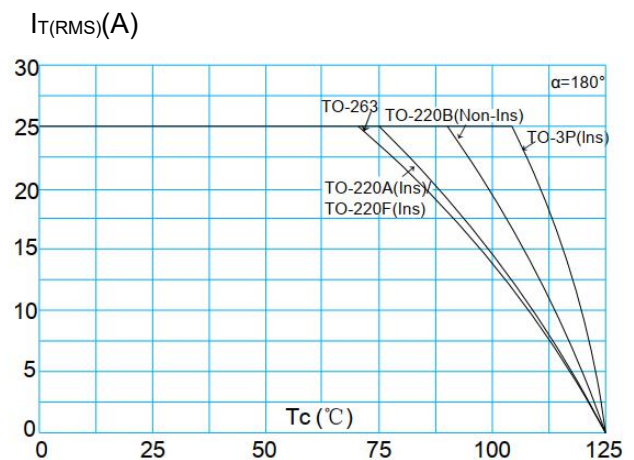

FIG.4: On-state characteristics (maximum values)

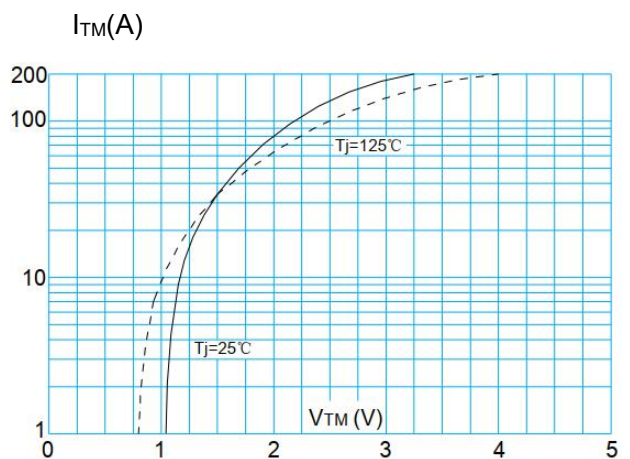
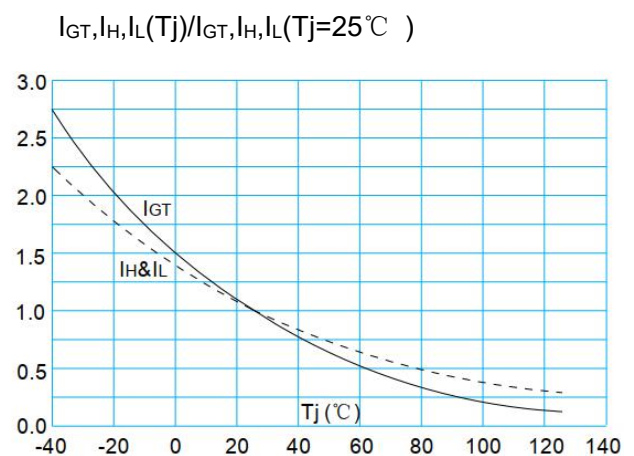

FIG.6: Relative variations of gate trigger current, holding current and latching current versus junction temperature





Jiangsu Weida Semiconductor Co., Ltd.
BTA26/BTB26 Series 25A Triacs

Information furnished in this document is believed to be accurate and reliable. However, Jiangsu Weida Semiconductor Co., Ltd assumes no responsibility for the consequences of use without consideration for such information nor use beyond it.

Information mentioned in this document is subject to change without notice, apart from that when an agreement is signed, Jiangsu Weida Semiconductor Co., Ltd complies with the agreement.

Products and information provided in this document have no infringement of patents. Jiangsu Weida Semiconductor Co., Ltd assumes no responsibility for any infringement of other rights of third parties which may result from the use of such products and information.

X-ON Electronics

Largest Supplier of Electrical and Electronic Components

Click to view similar products for [Triacs](#) category:

Click to view products by [Weida Semiconductor](#) manufacturer:

Other Similar products are found below :

[BT137-600-0Q](#) [2N6075A](#) [NTE5688](#) [D31410](#) [ACS102-5T1](#) [ACS102-5TA](#) [MAC97A4G](#) [Z0107MAG](#) [Z0107MARL1G](#) [Z0109MARLRPG](#)
[BTA316-800ET,127](#) [BTA316-800CTQ](#) [ACTT8X-800CTNQ](#) [MCR22-6G](#) [BTA16-800B\(MS\)](#) [TYN1025RG-JSM](#) [BT138-600D](#) [BTA26-800BRG](#) [BT138-600E](#) [BTA24-600CWRG](#) [BTA16-800CWRG](#) [BT138-600E](#) [BTA08-800CW](#) [BTB24-800CW](#) [BTA16-800CW](#) [BTA16-600CW](#) [BT169](#) [MCR100-6U](#) [FT10050-12P](#) [BT136-800E](#) [BT136S](#) [PCR606J](#) [CT404D-800S](#) [JST24A-800CW](#) [JST60IS-1600BW](#)
[TYN810RG-JSM](#) [BT139B-600E-JSM](#) [TYN812RG-JSM](#) [BTB16-800BRG-JSM](#) [BTA20-800CRG TO-220](#) [BTA16-800BRG](#) [BTW69-1200RG](#)
[TYN825RG-JSM](#) [BTA12-600CRG](#) [BT136-600E](#) [BTA12-600BRG](#) [BT139-600E](#) [BTA24-800CRG TO-220](#) [BTA16-800BWRG](#) [BTA26-600BWRG](#)