



Jiangsu Weida Semiconductor Co., Ltd

CJ431/CD431 Adjustable Reference Source

CJ431/CD431

Adjustable Accurate Reference Source

DEVICE DESCRIPTION

The CJ431/ CD431 is a three-terminal adjustable shunt regulator offering excellent temperature stability. This device has a typical dynamic output impedance of 0.2Ω. The device can be used as a replacement for zener diodes in many applications.

FEATURES

- The output voltage can be adjusted to 36V
- Low dynamic output impedance, its typical value is 0.2Ω
- Trapping current capability is 1 to 100mA
- Low output noise voltage
- Fast on -state response
- The effective temperature compensation in the working range of full temperature
- The typical value of the equivalent temperature factor in the whole temperature scope is 50 ppm/°C

APPLICATION

- Shunt Regulator
- High-Current Shunt Regulator
- Precision Current Limiter

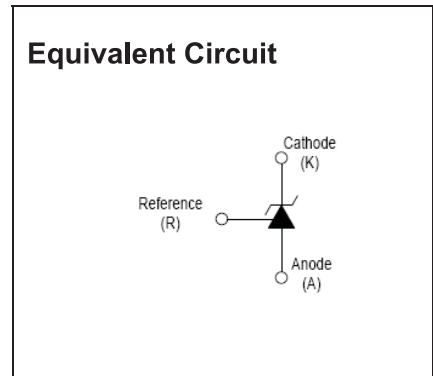

PIN CONNECTIONS and MARKING

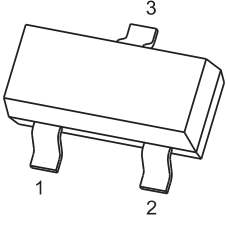
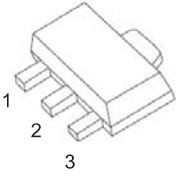
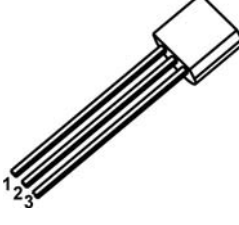
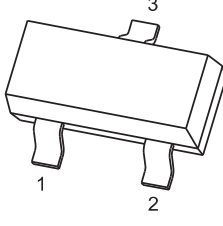
<p>CJ431</p> 	<p>SOT -23</p> <p>1.REFERENCE 2.CATHODE 3. ANODE</p>	<p>CJ431</p> 	<p>SOT-89</p> <p>1.REFERENCE 2.ANODE 3.CATHODE</p>
<p>CJ431</p> 	<p>TO-92</p> <p>1.REFERENCE 2.ANODE 3.CATHODE</p>	<p>CD431</p> 	<p>SOT-23</p> <p>1.CATHODE 2.REFERENCE 3. ANODE</p>

ORDERING INFORMATION

Part Number	MARKING ⁽¹⁾	Package	Packing Method	Pack Quantity
CJ431	431	SOT-23	Reel	3000pcs/Reel
CD431	CD431	SOT-23	Reel	3000pcs/Reel
CJ431	CJ431	SOT-89	Reel	1000pcs/Reel
CJ431	CJ TL431 XXX ⁽²⁾	TO-92	Bulk	1000pcs/Bag
CJ431-TA	CJ TL431 XXX ⁽²⁾	TO-92	Tape	2000pcs/Box

Notes: (1). Solid dot= Green molding compound device, if none, the normal device.

(2). XXX=Code

ABSOLUTE MAXIMUM RATINGS (Operating temperature range applies unless otherwise specified)

Parameter	Symbol	Value			Unit
		SOT-23	SOT-89	TO-92	
Cathode Voltage	V_{KA}	36			V
Cathode Current Range (Continuous)	I_{KA}	-100~+150			mA
Reference Input Current Range	I_{ref}	0.05~+10			mA
Power Dissipation	P_D	300	500	770	mW
Thermal Resistance from Junction to Ambient	$R_{\theta JA}$	417	250	162	°C/W
Operating Temperature	T_{opr}	-25~+85			°C
Junction Temperature	T_J	150			°C
Storage Temperature Range	T_{STG}	-65~+150			°C

ELECTRICAL CHARACTERISTICS ($T_a=25^\circ\text{C}$ unless otherwise specified)

Parameter	Symbol	Test conditions	Min	Typ	Max	Unit
Reference input voltage	V_{ref}	$V_{KA}=V_{REF}, I_{KA}=10\text{mA}$	2.475	2.5	2.525	V
Deviation of reference Input voltage over temperature (note)	$\Delta V_{ref}/\Delta T$	$V_{KA}=V_{REF}, I_{KA}=10\text{mA}$ $T_{MIN}\leq T_a\leq T_{MAX}$		4.5	17	mV
Ratio of change in reference Input voltage to the change in cathode voltage	$\Delta V_{ref}/\Delta V_{KA}$	$I_{KA}=10\text{mA}$	$\Delta V_{KA}=10\text{V}\sim V_{REF}$	-1.0	-2.7	mV/V
			$\Delta V_{KA}=36\text{V}\sim 10\text{V}$	-0.5	-2.0	mV/V
Reference input current	I_{ref}	$I_{KA}=10\text{mA}, R_1=10\text{k}\Omega$ $R_2=\infty$		1.5	4	μA
Deviation of reference input current over full temperature range	$\Delta I_{ref}/\Delta T$	$I_{KA}=10\text{mA}, R_1=10\text{k}\Omega$ $R_2=\infty$ $T_A=-25$ to 85°C		0.4	1.2	μA
Minimum cathode current for regulation	$I_{KA(min)}$	$V_{KA}=V_{REF}$		0.45	1.0	mA
Off-state cathode current	$I_{KA(OFF)}$	$V_{KA}=36\text{V}, V_{REF}=0$		0.05	1.0	μA
Dynamic impedance	Z_{KA}	$V_{KA}=V_{REF}, I_{KA}=1$ to 100mA $f\leq 1.0\text{kHz}$		0.15	0.5	Ω

Note: $T_{MIN}=-25^\circ\text{C}$, $T_{MAX}=+85^\circ\text{C}$

CLASSIFICATION cZV_{ref}

Rank	0.5%	1%
Range	2.487-2.513	2.475-2.525

Typical Characteristics

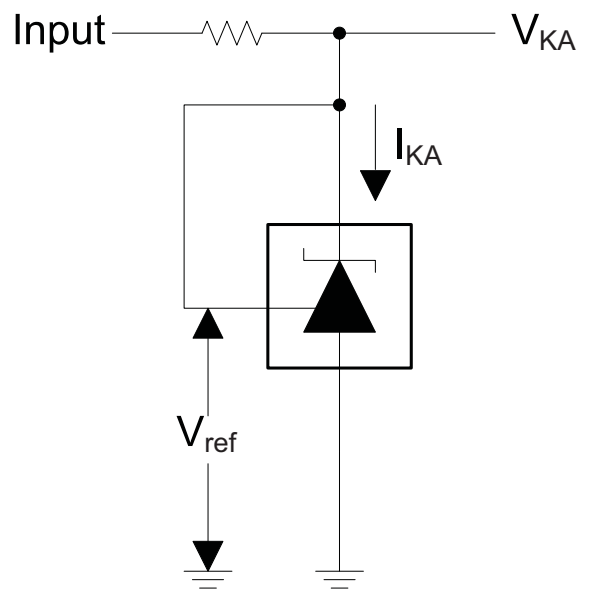
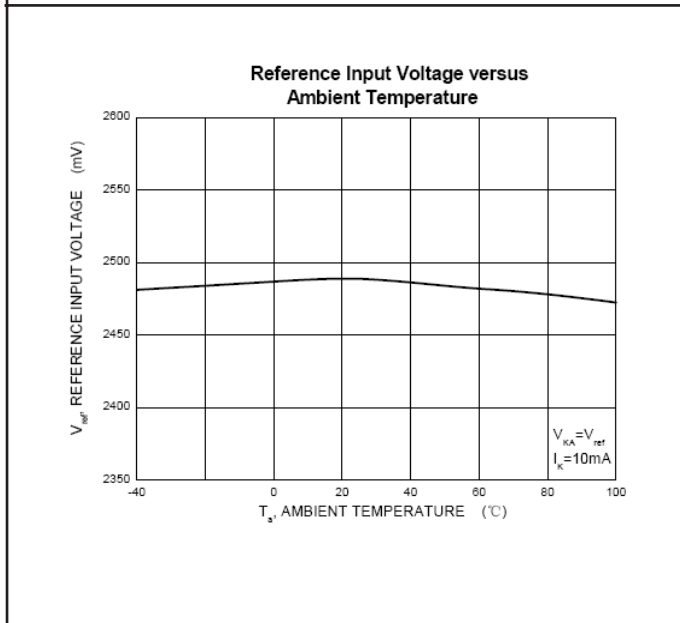
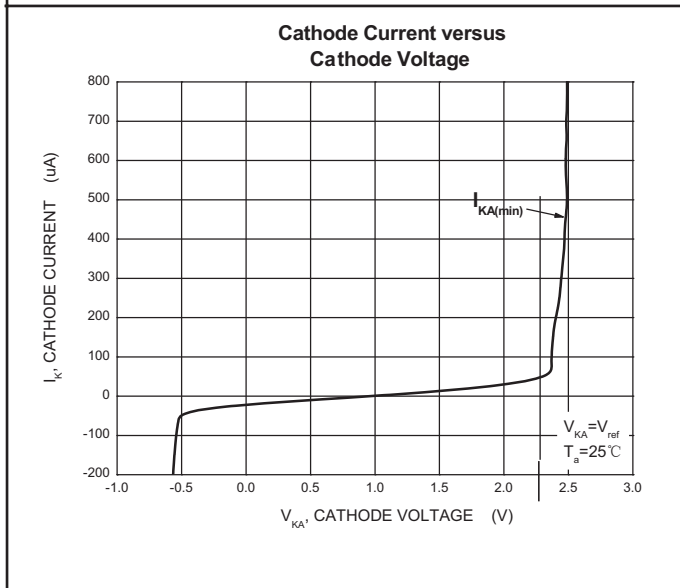
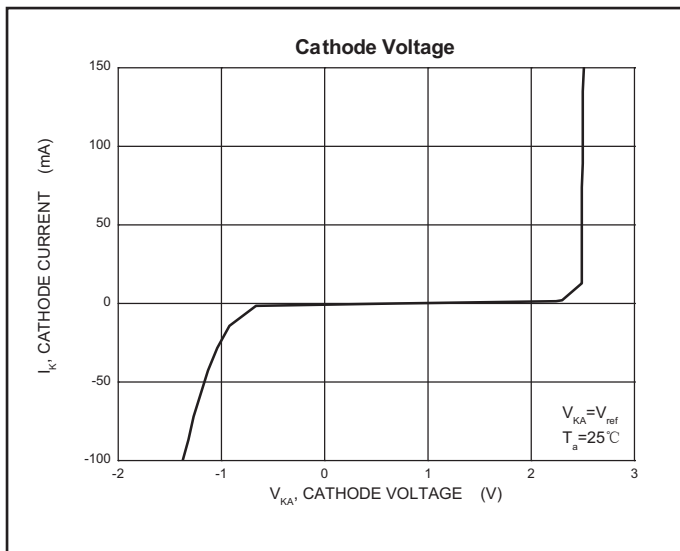

Test Circuit for $V_{KA} = V_{ref}$

Typical Characteristics

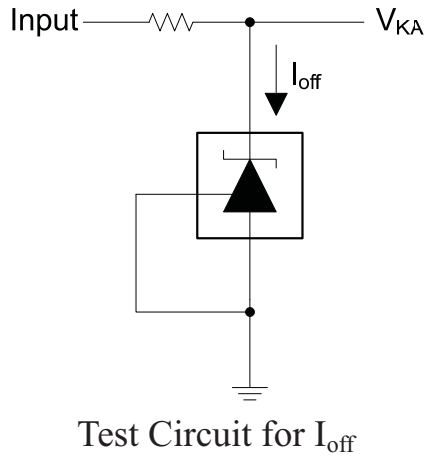
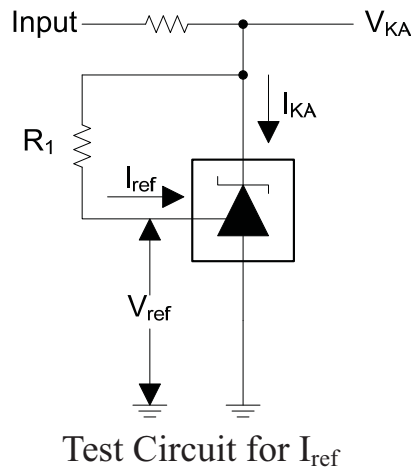
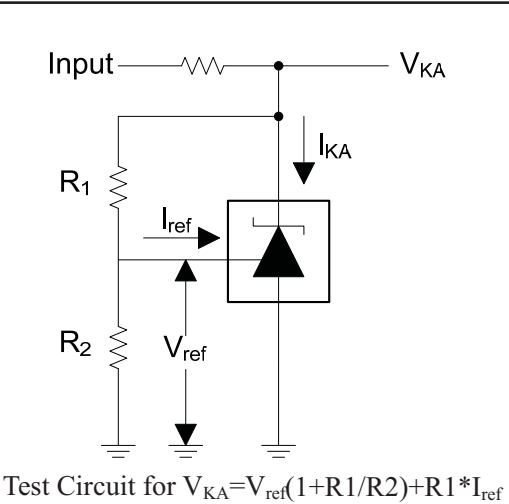
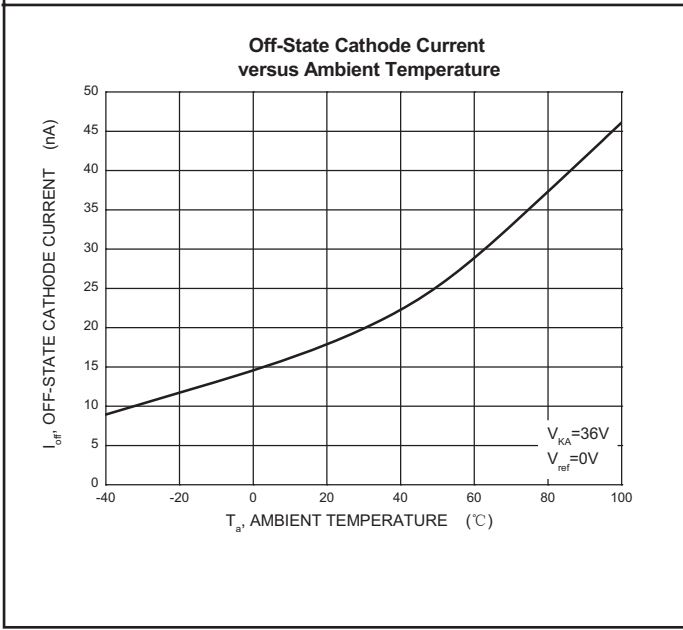
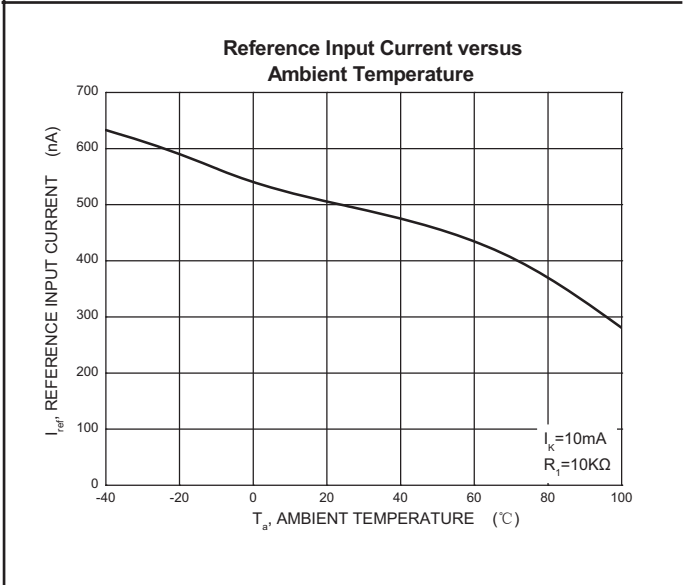
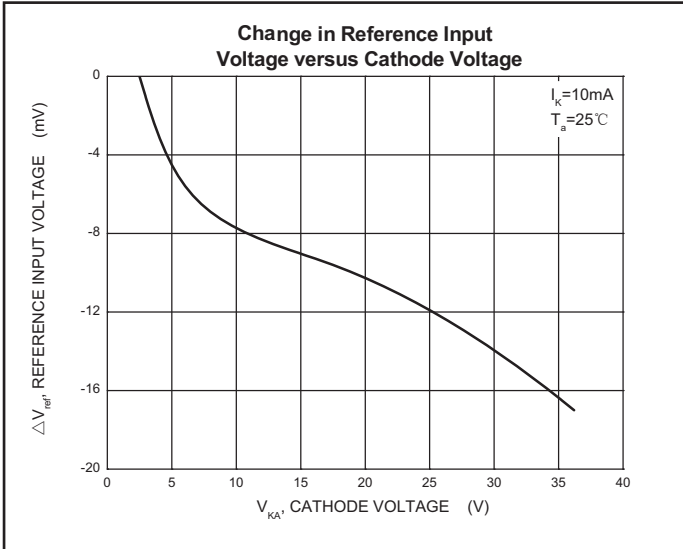

SOT-23 Package Outline Dimensions

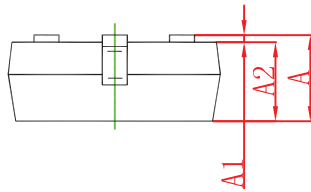
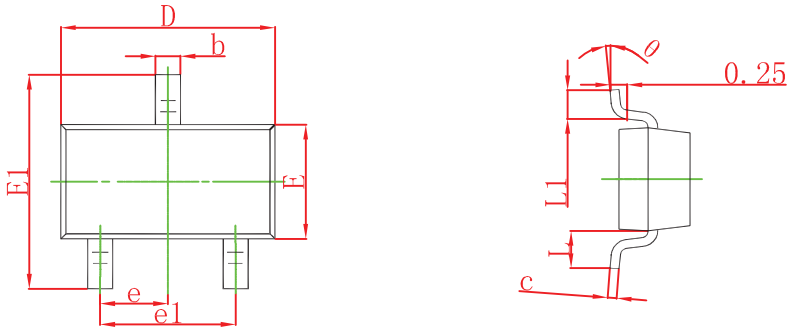

Symbol	Dimensions In Millimeters		Dimensions In Inches	
	Min	Max	Min	Max
A	0.900	1.150	0.035	0.045
A1	0.000	0.100	0.000	0.004
A2	0.900	1.050	0.035	0.041
b	0.300	0.500	0.012	0.020
c	0.080	0.150	0.003	0.006
D	2.800	3.000	0.110	0.118
E	1.200	1.400	0.047	0.055
E1	2.250	2.550	0.089	0.100
e	0.950 TYP		0.037 TYP	
e1	1.800	2.000	0.071	0.079
L	0.550 REF		0.022 REF	
L1	0.300	0.500	0.012	0.020
θ	0°	8°	0°	8°

SOT-23 Suggested Pad Layout

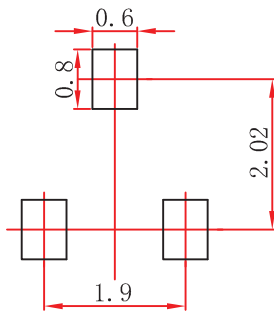

- Note:
1. Controlling dimension: in millimeters.
 2. General tolerance: $\pm 0.05\text{mm}$.
 3. The pad layout is for reference purposes only.

SOT-23 Tape and Reel

SOT-23 Embossed Carrier Tape

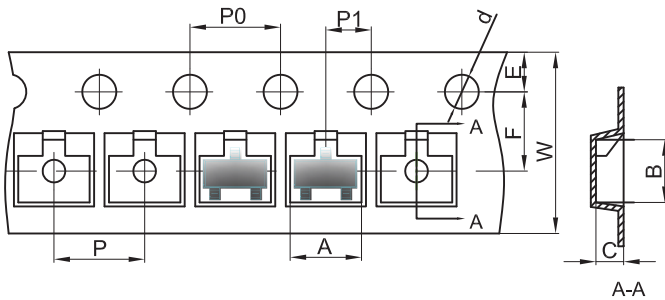

Packaging Description:

SOT-23 parts are shipped in tape. The carrier tape is made from a dissipative (carbon filled) polycarbonate resin. The cover tape is a multilayer film (Heat Activated Adhesive in nature) primarily composed of polyester film, adhesive layer, sealant, and anti-static sprayed agent. These reeled parts in standard option are shipped with 3,000 units per 7" or 17.8cm diameter reel. The reels are clear in color and is made of polystyrene plastic (anti-static coated).

Dimensions are in millimeter

Pkg type	A	B	C	d	E	F	P0	P	P1	W
SOT-23	3.15	2.77	1.22	Ø1.50	1.75	3.50	4.00	4.00	2.00	8.00

SOT-23 Tape Leader and Trailer

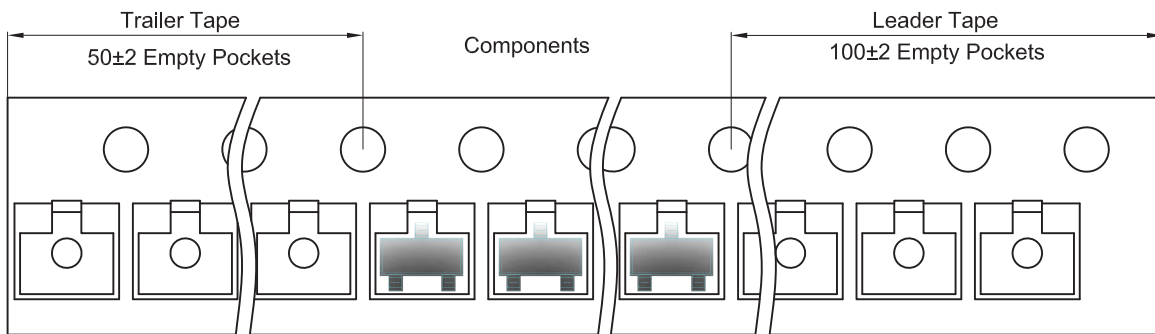

SOT-23 Reel

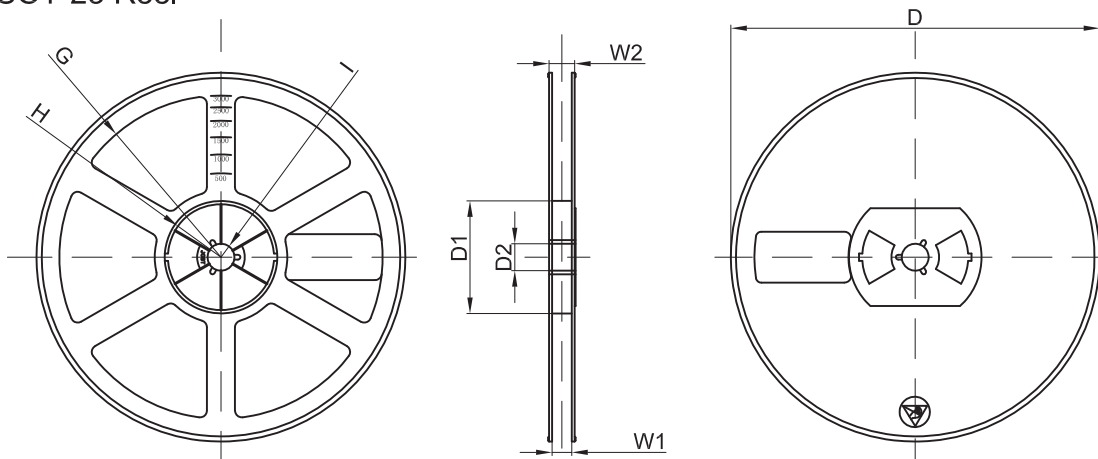

Dimensions are in millimeter

Reel Option	D	D1	D2	G	H	I	W1	W2
7"Dia	Ø178.00	54.40	13.00	R78.00	R25.60	R6.50	9.50	12.30

REEL	Reel Size	Box	Box Size(mm)	Carton	Carton Size(mm)	G.W.(kg)
3000 pcs	7 inch	45,000 pcs	203×203×195	180,000 pcs	438×438×220	

SOT-89-3L Tape and reel

SOT-89-3L Embossed Carrier Tape

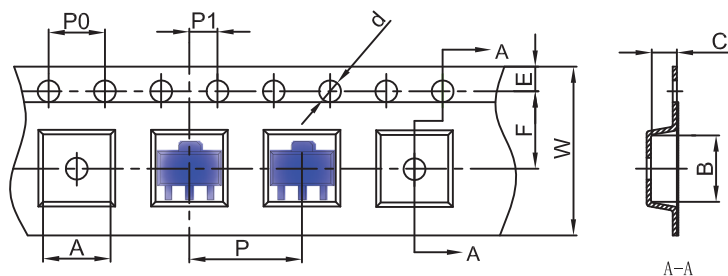

Packaging Description:
 SOT-89-3L parts are shipped in tape. The carrier tape is made from a dissipative (carbon filled) polycarbonate resin. The cover tape is a multilayer film (Heat Activated Adhesive in nature) primarily composed of polyester film, adhesive layer, sealant, and anti-static sprayed agent. These reeled parts in standard option are shipped with 1,000 units per 7" or 18.0 cm diameter reel. The reels are clear in color and is made of polystyrene plastic (anti-static coated).

Dimensions are in millimeter										
Pkg type	A	B	C	d	E	F	P0	P	P1	W
SOT-89-3L	4.85	4.45	1.85	Ø1.50	1.75	5.50	4.00	8.00	2.00	12.00

SOT-89-3L Tape Leader and Trailer

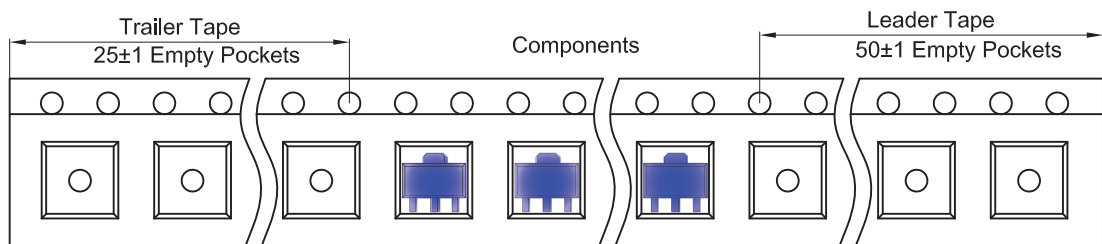

SOT-89-3L Reel

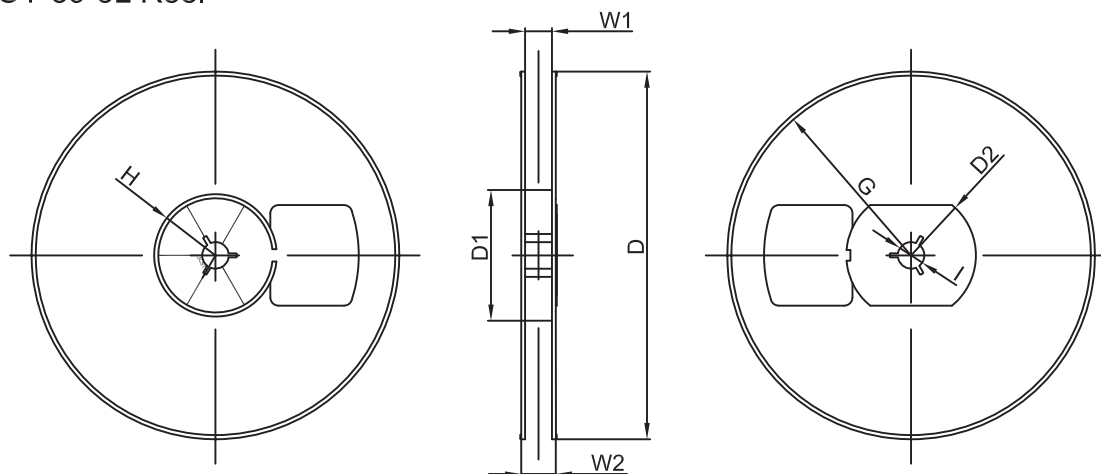

Dimensions are in millimeter								
Reel Option	D	D1	D2	G	H	I	W1	W2
7" Dia	Ø180.00	60.00	R32.00	R86.50	R30.00	Ø13.00	13.20	16.50

REEL	Reel Size	Box	Box Size(mm)	Carton	Carton Size(mm)	G.W.(kg)
1000 pcs	7 inch	10,000 pcs	203×203×195	40,000 pcs	438×438×220	

TO-92 Package Outline Dimensions

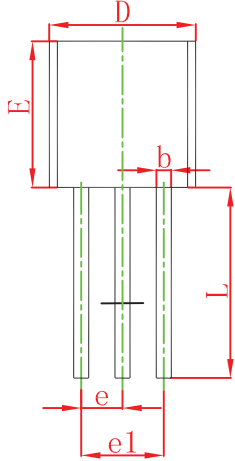
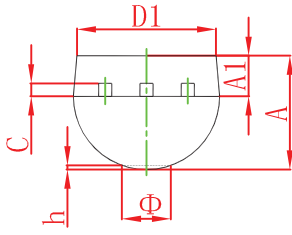

Symbol	Dimensions In Millimeters		Dimensions In Inches	
	Min	Max	Min	Max
A	3.300	3.700	0.130	0.146
A1	1.100	1.400	0.043	0.055
b	0.380	0.550	0.015	0.022
c	0.360	0.510	0.014	0.020
D	4.300	4.700	0.169	0.185
D1	3.430		0.135	
E	4.300	4.700	0.169	0.185
e	1.270 TYP		0.050 TYP	
e1	2.440	2.640	0.096	0.104
L	14.100	14.500	0.555	0.571
Φ		1.600		0.063
h	0.000	0.380	0.000	0.015

TO-92 Suggested Pad Layout

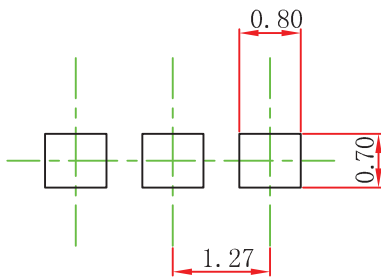

Note:

1. Controlling dimension: in millimeters.
2. General tolerance: $\pm 0.05\text{mm}$.
3. The pad layout is for reference purposes only.

TO-92 PACKAGE TAPEING DIMENSION

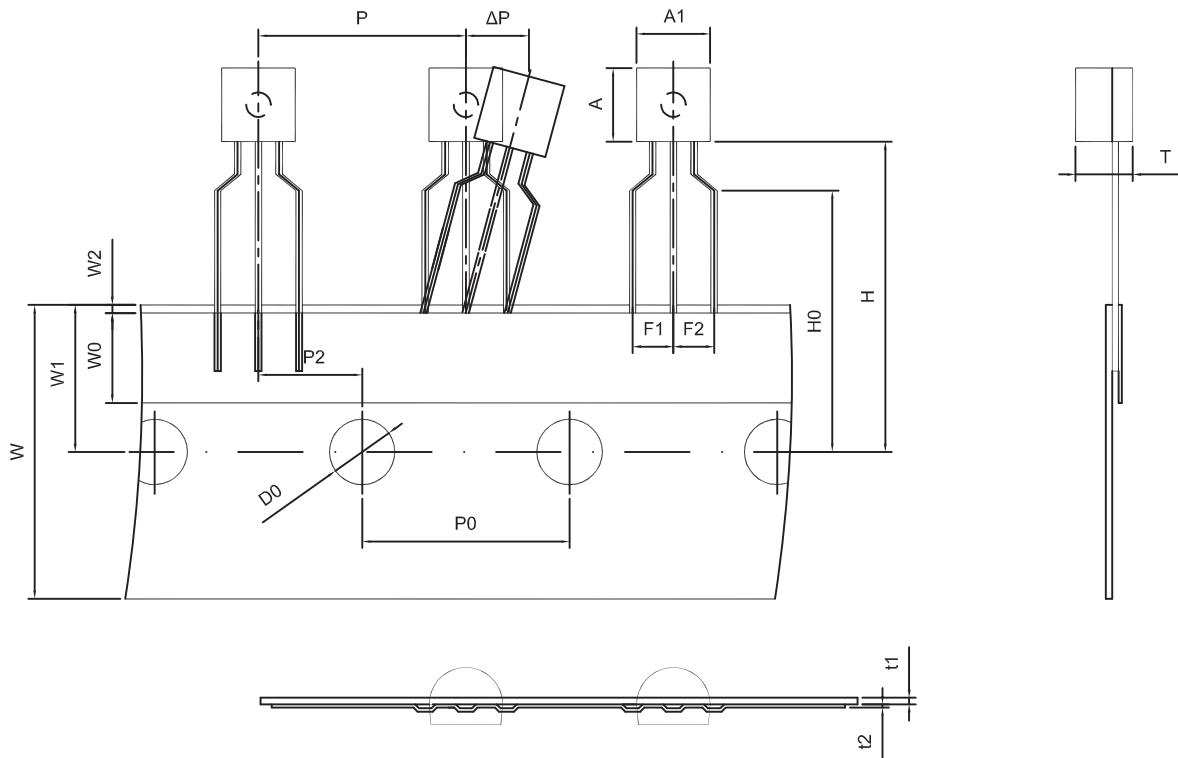

Dimiensions are in millimeter								
A1	A	T	P	P0	P2	F1	F2	W
4.5	4.5	3.5	12.7	12.7	6.35	2.5	2.5	18.0
W0	W1	W2	H	H0	D0	t1	t2	ΔP
6.0	9.0	1.0 MAX.	19.0	16.0	4.0	0.4	0.2	0

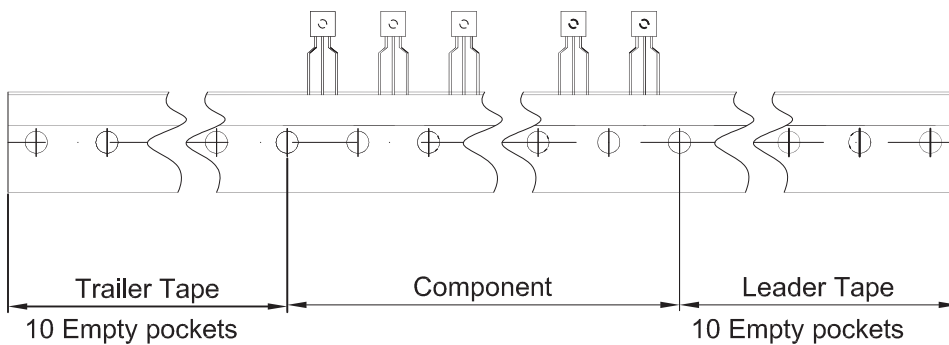

Package	Box	Box Size(mm)	Carton	Carton Size(mm)
TO-92	2000 pcs	333×162×43	20,000 pcs	350×340×250

X-ON Electronics

Largest Supplier of Electrical and Electronic Components

Click to view similar products for [Voltage References](#) category:

Click to view products by [Weida Semiconductor](#) manufacturer:

Other Similar products are found below :

[5962-8686103XC](#) [REF01J/883](#) [SC431ILPRAG](#) [AP432AQG-7](#) [LM4040B25QFTA](#) [EL5226IR](#) [EL5326IR](#) [EL5326IRZ](#) [ISL21007DFB825Z](#)
[ISL21009BFB812Z](#) [ISL21009CFB812Z](#) [ISL60002BIH312](#) [TS3320AMR](#) [TS3325AMR](#) [TS3330AMR](#) [TS3333AMR](#) [X60003CIG3-41](#)
[X60003DIG3Z-41T1](#) [X60250V8I](#) [REF3025TB-GT3](#) [SC432BVSNT1G](#) [TL431CPG](#) [LM336Z-5.0](#) [MRTL432](#) [TL431A](#) [LR432ATLT1G](#)
[TL432](#) [TL431A](#) [TL431NSG-AE2-R](#) [TL432](#) [TL431](#) [TL431](#) [CD431A](#) [TL432](#) [LM285M3-2.5/TR](#) [TL432AIM3/TR](#) [LM431AIM3/TR](#)
[MC1403MM/TR](#) [TL431CM3/TR](#) [HT432ARTZ](#) [TL431Z-AST](#) [LTL431APKLT1G](#) [JD431A](#) [431S](#) [TL432](#) [WD431NTR-BG](#) [CJ431](#) [CD431](#)
[TL431A 0.4%](#) [ADR4520ARZ-R7](#)