



MBRS10150CT 10A High Voltage Power Schottky Rectifier

General Description

High voltage dual Schottky rectifier suited for switch mode power supplies and other power converters. This device is intended for use in medium voltage operation, and particularly, in high frequency circuits where low switching losses and low noise are required.

Main Product Characteristics

symbol	value	unit
$I_{F(AV)}$	2x5	A
V_{RRM}	150	V
V_F	≤ 0.95	V
T_J	150	°C

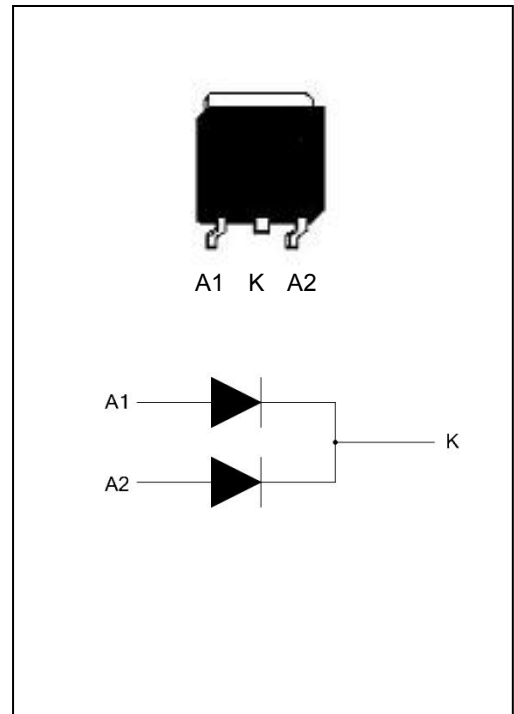

Features

- High Surge Capacity
- 150°C Operating Junction Temperature
- 10A Total (5A Per Diode Leg)
- Guard-ring for Stress Protection
- Pb-free Packages are Available

Absolute Maximum Ratings (Per Diode Leg)

Parameter	Symbol	Value	Unit
Storage junction temperature range	T_{stg}	-55~150	°C
Operating junction temperature range	T_j	150	°C
Repetitive peak reverse voltage ($T_j=25^\circ\text{C}$)	V_{RRM}	150	V
Working Peak Reverse Voltage	V_{RWM}	105	V
DC Blocking Voltage	V_R	150	V
Average Rectified Forward Current(Rated V_R) $T_C=142^\circ\text{C}$	$I_{F(AV)}$	10	A



MBRS10150CT 10A High Voltage Power Schottky Rectifier

Peak Repetitive Forward Current (Rated V_R , Square Wave, 20kHz) $T_C=142^\circ\text{C}$	I_{FRM}	10	A
Non Repetitive Peak Surge Current (Surge Applied at Rated Load Conditions Half Wave, Single Phase, 60Hz)	I_{FSM}	120	A
Voltage Rate of Change (Rated V_R)	dv/dt	10000	V/ μs

Electrical Characteristics ($T_j=25^\circ\text{C}$ unless otherwise specified)

Parameter	Symbol	Test Condition	Value (Max)	Unit
Maximum Instantaneous Forward Voltage Drop	V_F	$I_F=5\text{A}$	0.95	V
Maximum Instantaneous Reverse Current Drop	I_R	$V_R=155\text{V}$	5	μA

Ordering Information

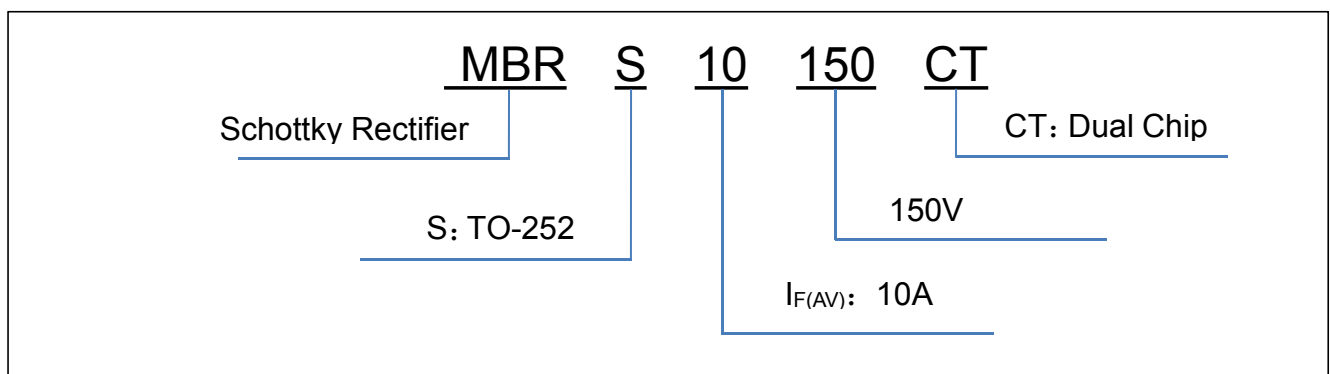



MBRS10150CT 10A High Voltage Power Schottky Rectifier

Package Mechanical Data

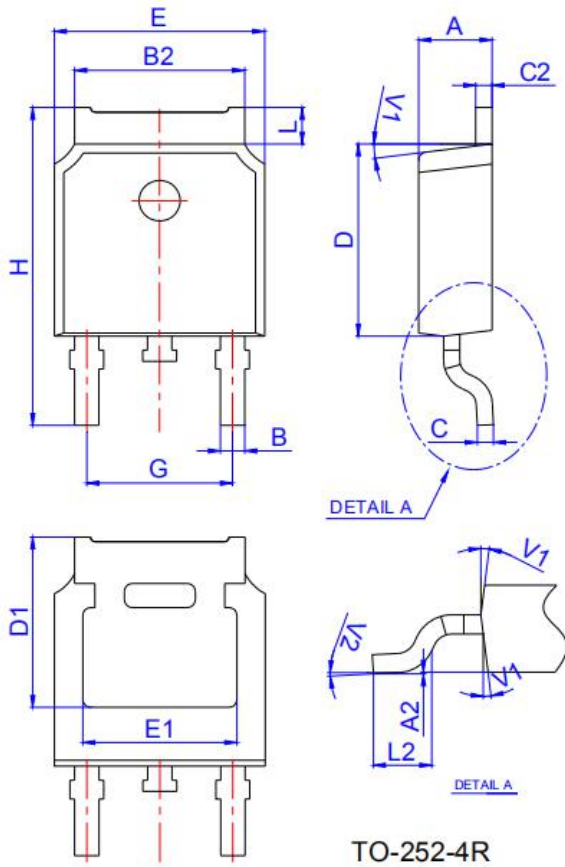

Ref.	Dimensions					
	Millimeters			Inches		
	Min.	Typ.	Max.	Min.	Typ.	Max.
A	2.10		2.50	0.083		0.098
A2	0		0.10	0		0.004
B	0.66		0.86	0.026		0.034
B2	5.18		5.48	0.202		0.216
C	0.40		0.60	0.016		0.024
C2	0.44		0.58	0.017		0.023
D	5.90		6.30	0.232		0.248
D1	5.30REF			0.209REF		
E	6.40		6.80	0.252		0.268
E1	4.63			0.182		
G	4.47		4.67	0.176		0.184
H	9.50		10.70	0.374		0.421
L	1.09		1.21	0.043		0.048
L2	1.35		1.65	0.053		0.065
V1		7°			7°	
V2	0°		6°	0°		6°

Fig. 1: Average forward power dissipation versus average forward current (per diode).

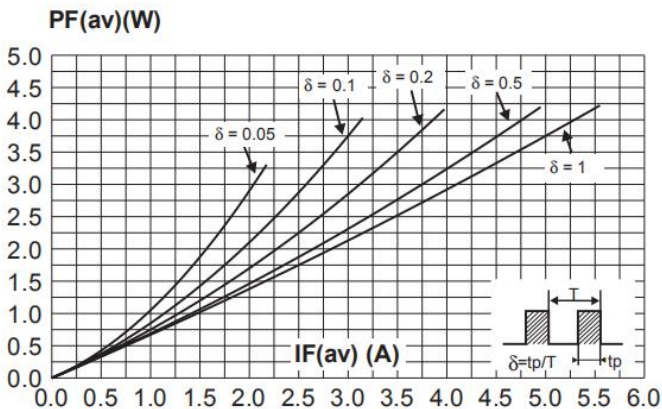
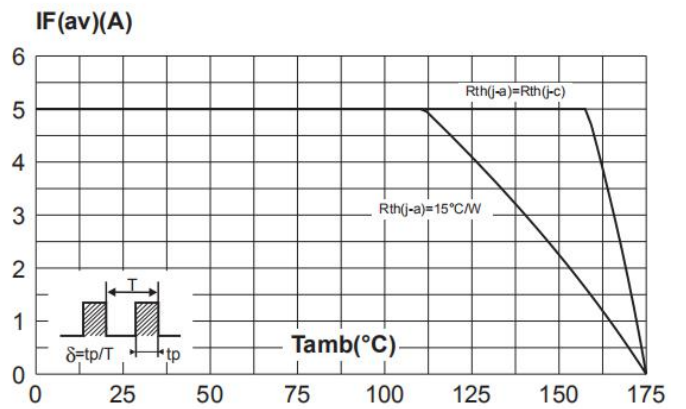

Fig. 2: Average forward current versus ambient temperature ($\delta = 0.5$, per diode).





MBRS10150CT 10A High Voltage Power Schottky Rectifier

Fig. 3: Non repetitive surge peak forward current versus overload duration (maximum values, per diode).

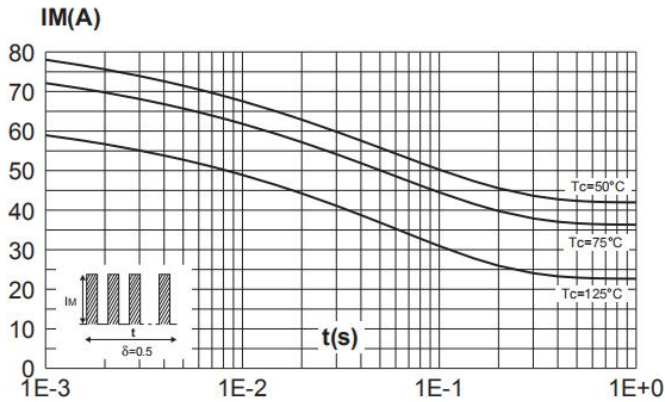

Fig. 5: Reverse leakage current versus reverse voltage applied (typical values, per diode)

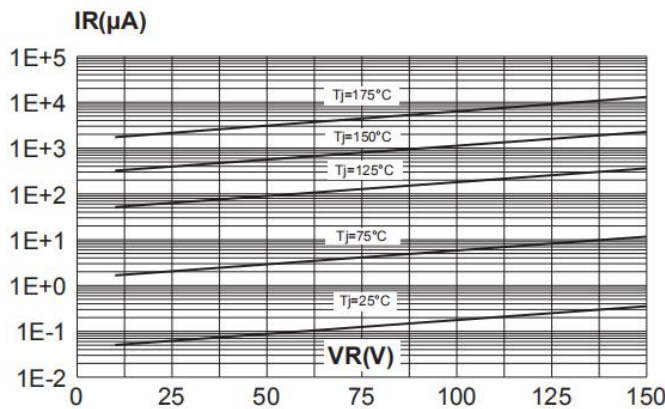

Fig. 3: Non repetitive surge peak forward current versus overload duration (maximum values, per diode).

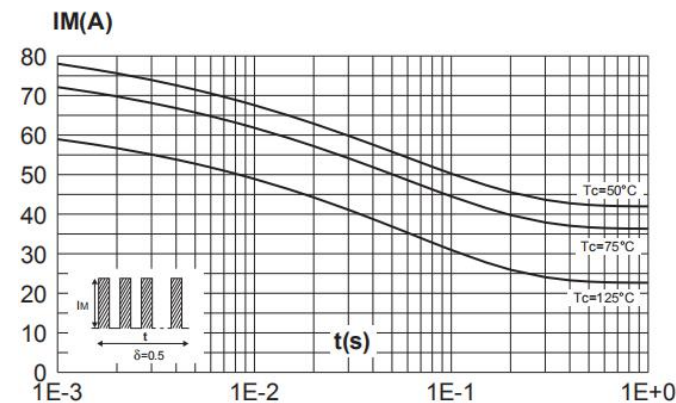

Fig. 4: Relative variation of thermal impedance junction to case versus pulse duration (per diode).

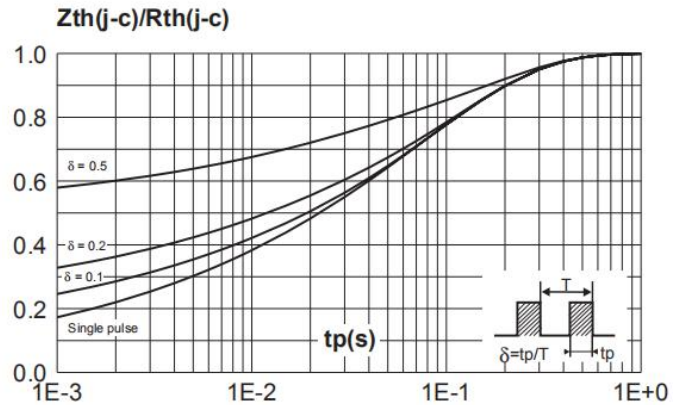

Fig. 6: Junction capacitance versus reverse voltage applied (typical values, per diode).

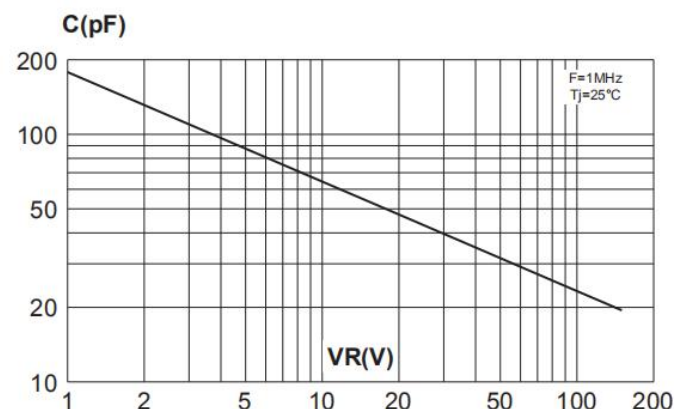
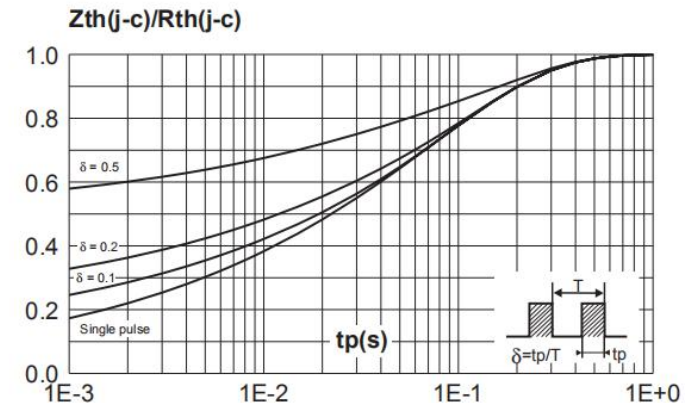

Fig. 4: Relative variation of thermal impedance junction to case versus pulse duration (per diode).





Jiangsu Weida Semiconductor Co., Ltd.

MBRS10150CT 10A High Voltage Power Schottky Rectifier

Information furnished in this document is believed to be accurate and reliable. However, Jiangsu Weida Semiconductor Co., Ltd assumes no responsibility for the consequences of use without consideration for such information nor use beyond it.

Information mentioned in this document is subject to change without notice, apart from that when an agreement is signed, Jiangsu Weida Semiconductor Co., Ltd complies with the agreement.

Products and information provided in this document have no infringement of patents. Jiangsu Weida Semiconductor Co., Ltd assumes no responsibility for any infringement of other rights of third parties which may result from the use of such products and information.

X-ON Electronics

Largest Supplier of Electrical and Electronic Components

Click to view similar products for [Schottky Diodes & Rectifiers](#) category:

Click to view products by [Weida Semiconductor](#) manufacturer:

Other Similar products are found below :

[MA4E2039](#) [MMBD301M3T5G](#) [RB160M-50TR](#) [D83C](#) [BAS16E6433HTMA1](#) [BAS 3010S-02LRH E6327](#) [BAT 54-02LRH E6327](#)
[NRVBAF360T3G](#) [NSR05F40QNXT5G](#) [NTE555](#) [JANS1N6640](#) [SS3003CH-TL-E](#) [GA01SHT18](#) [CRS10I30A\(TE85L,QM](#) [MBRA140TRPBF](#)
[MBRB30H30CT-1G](#) [BAT 15-04R E6152](#) [JANTX1N5712-1](#) [DMJ3940-000](#) [SB007-03C-TB-E](#) [NRVBB20100CTT4G](#) [NRVBM120LT1G](#)
[NTSB30U100CT-1G](#) [CRG04\(T5L,TEMQ\)](#) [ACDBA1100LR-HF](#) [ACDBA1200-HF](#) [ACDBA240-HF](#) [ACDBA3100-HF](#) [CDBQC0530L-HF](#)
[ACDBA260LR-HF](#) [ACDBA1100-HF](#) [10BQ015-M3/5BT](#) [NRVBM120ET1G](#) [VSSB410S-M3/5BT](#) [1N5819T-G](#) [PDS1040Q-13](#) [B160BQ-13-F](#)
[SDM05U20CSP-7](#) [BAS 70-07 E6433](#) [B140S1F-7](#) [HSM560Je3/TR13](#) [DDB2265-000](#) [ZHCS506QTA](#) [HSM190Je3/TR13](#) [B330AF-13](#)
[ACDBUC0230-HF](#) [SDM1U100S1F-7](#) [MBR10200CTF-G1](#) [CDLL5712](#) [DMF2822-000](#)