



# Jiangsu Weida Semiconductor Co., Ltd.

## MCR100-8 Series 0.8A Sensitive SCRs

### DESCRIPTION:

The MCR100-8 SCR series provide high dv/dt rate with strong resistance to electromagnetic interference. They are especially recommended for use on residual current circuit breaker, straight hair, igniter etc.

### MAIN FEATURES:

symbol	value	unit
$I_{T(RMS)}$	1	A
$V_{DRM}/V_{RRM}$	600/800	V
$V_{TM}$	$\leq 1.5$	V

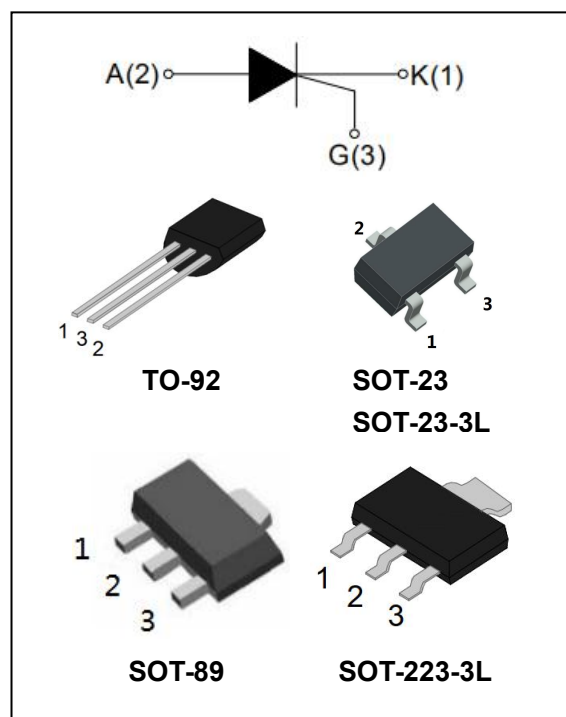

### ABSOLUTE MAXIMUM RATINGS:

Parameter	Symbol	Value	Unit
Storage junction temperature range	$T_{stg}$	-40~150	$^{\circ}C$
Operating junction temperature range	$T_j$	-40~110	$^{\circ}C$
Repetitive peak off-state voltage ( $T_j=25^{\circ}C$ )	$V_{DRM}$	600/800	V
Repetitive peak reverse voltage ( $T_j=25^{\circ}C$ )	$V_{RRM}$	600/800	V
RMS on-state current	$I_{T(RMS)}$	0.8	A
Non repetitive surge peak on-state current (full cycle, $F=50Hz$ )	$I_{TSM}$	8	A
$I^2t$ value for fusing ( $t_p=10ms$ )	$I^2t$	0.32	$A^2s$
Critical rate of rise of on-state current ( $I_G=2 \times I_{GT}$ )	$di/dt$	50	$A/\mu s$
Peak gate current	$I_{GM}$	0.2	A
Average gate power dissipation	$P_{G(AV)}$	0.1	W
Peak gate power	$P_{GM}$	0.5	W



**Jiangsu Weida Semiconductor Co., Ltd.**  
**MCR100-8 Series 0.8A Sensitive SCRs**

**ELECTRICAL CHARACTERISTICS** ( $T_j=25^{\circ}\text{C}$  unless otherwise specified)

Symbol	Test Condition	Value			Unit
		MIN	TYPE	MAX	
$I_{GT}$	$V_D=12\text{V}, R_L=33\Omega$	-	20	200	$\mu\text{A}$
$V_{GT}$		-	0.6	0.8	V
$V_{GD}$	$V_D=V_{DRM}, T_j=110^{\circ}\text{C}$ $R_L=3.3\text{k}\Omega$	0.2	-	-	V
$I_H$	$I_T=50\text{mA}$	-	-	5	mA
$I_L$	$I_G=1.2I_{GT}$	-	-	6	mA
dV/dt	$V_D=0.66 \times V_{DRM}, T_j=110^{\circ}\text{C}$ G 极开路 $R_{GK}=1\text{k}\Omega$	10	-	-	V/ $\mu\text{s}$

**STATIC CHARACTERISTICS**

Symbol	Test Condition		Value	Unit	
$V_{TM}$	$I_{TM}=1\text{A}$	$t_p=380\mu\text{s}$	MAX	1.5	V
$I_{DRM}$ $I_{RRM}$	$V_{DRM}=V_{RRM}$ $R_{GK}=1\text{k}\Omega$	$T_j=25^{\circ}\text{C}$	MAX	5	$\mu\text{A}$
		$T_j=110^{\circ}\text{C}$		100	$\mu\text{A}$

**THERMAL RESISTANCES**

Symbol	Test Condition		Value	Unit
$R_{th(j-c)}$	结到外壳(AC)	SOT-223	31	$^{\circ}\text{C}/\text{W}$
		TO-92	75	
		SOT-23 SOT-23-3L		
		SOT-89	45	



**Jiangsu Weida Semiconductor Co., Ltd.**  
**MCR100-8 Series 0.8A Sensitive SCRs**

**ORDERING INFORMATION**

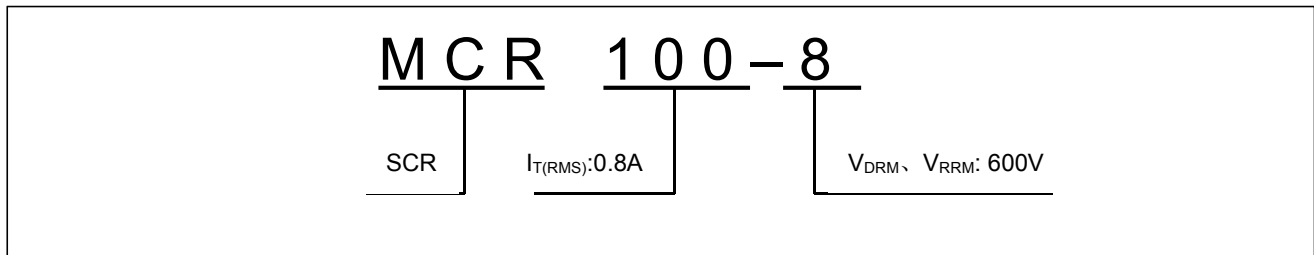

**PACKAGE MECHANICAL DATA**

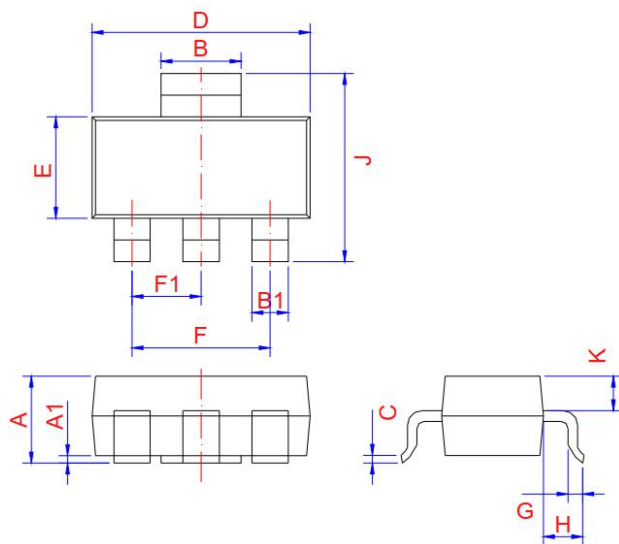

**SOT-223-3L**

Ref.	Dimensions					
	Millimeters			Inches		
	Min.	Typ.	Max.	Min.	Typ.	Max.
A	1.5	1.6	1.8	0.059	0.063	0.071
A1	0.01	0.06	0.10	0.001	0.002	0.004
B	2.9	3.0	3.1	0.114	0.118	0.122
B1	0.6	0.7	0.8	0.024	0.028	0.031
C	0.22	0.25	0.32	0.009	0.010	0.013
D	6.3	6.5	6.7	0.248	0.256	0.264
E	3.3	3.5	3.7	0.130	0.138	0.146
F		4.6	6.8	0.252	0.181	
F1		2.3			0.091	
G	0.7	0.9	1.1	0.028	0.035	0.043
H	1.5	1.75	2.0	0.059	0.069	0.079
J	6.7	7.0	7.3	0.264	0.276	0.287
K	0.8	0.9	1.0	0.031	0.035	0.039

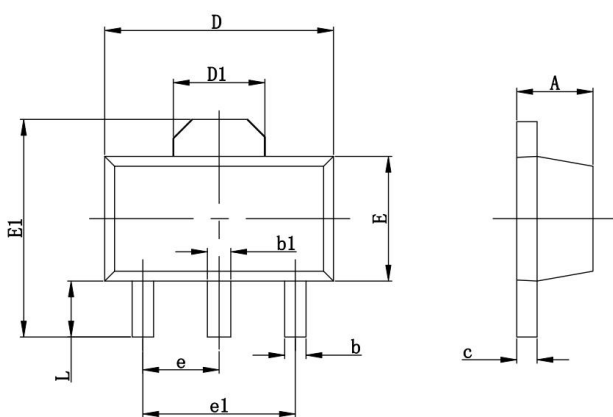

**SOT-89-3L**

Ref.	Dimensions					
	Millimeters			Inches		
	Min.	Typ.	Max.	Min.	Typ.	Max.
A	1.4		1.6	0.055		0.063
b	0.35		0.52	0.013		0.197
b1	0.4		0.58	0.016		0.023
c	0.35		0.44	0.014		0.017
D	4.4		4.6	0.173		0.181
D1		1.55			0.061	
E	2.35		2.55	0.091		0.102
E1	3.94		4.25	0.155		0.167
e		1.500			0.060	
e1		3.000			0.118	
L	0.9		1.1	0.035		0.047



**Jiangsu Weida Semiconductor Co., Ltd.**  
**MCR100-8 Series 0.8A Sensitive SCRs**

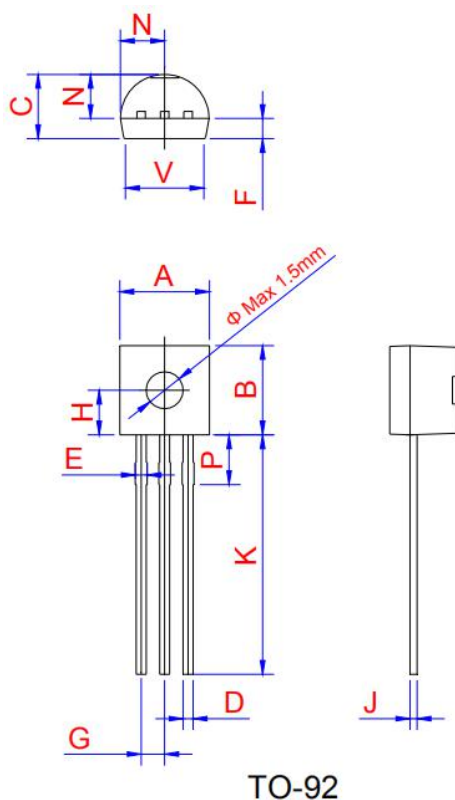

Ref.	Dimensions					
	Millimeters			Inches		
	Min.	Typ.	Max.	Min.	Typ.	Max.
A	4.45	4.6	5.2	0.175	0.181	0.205
B	4.32	4.6	5.33	0.17	0.181	0.21
C	3.18	3.55	4.19	0.125	0.14	0.165
D	0.407		0.533	0.016		0.021
E	0.6		0.8	0.024	0	0.031
F	-	1.1	-	-	0.043	-
G	-	1.27	-	-	0.05	-
H	-	2.3	-	-	0.091	-
J	0.36	0.38	0.5	0.014	0.015	0.02
K	12.7		15	0.5		0.591
N	2.04	2.3	2.66	0.08	0.091	0.105
P	1.86		2.06	0.073		0.081
V	-		4.3	-		0.169

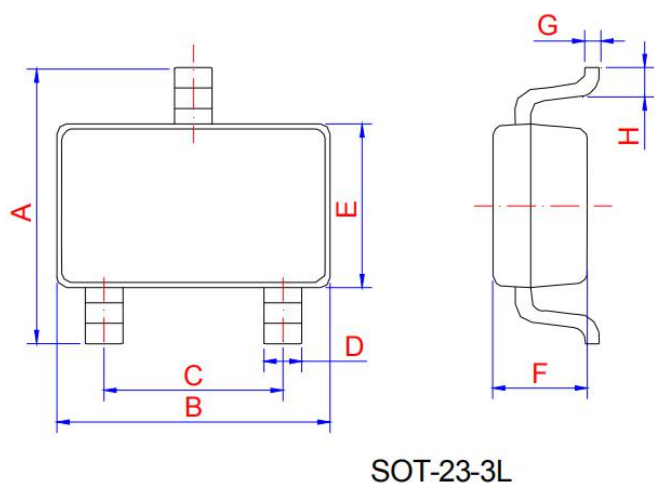

Ref.	Dimensions					
	Millimeters			Inches		
	Min.	Typ.	Max.	Min.	Typ.	Max.
A	2.65	2.8	2.95	0.104	0.11	0.116
B	2.82	2.92	3.02	0.111	0.115	0.119
C	1.8	1.9	2	0.071	0.075	0.079
D	0.3	0.35	0.5	0.012	0.014	0.02
E	1.5	1.6	1.7	0.059	0.063	0.067
F	1.07	1.17	1.27	0.042	0.046	0.05
G	0.05	0.15	0.25	0.002	0.006	0.01
H	0.25	0.4	0.55	0.01	0.016	0.022



**Jiangsu Weida Semiconductor Co., Ltd.**  
**MCR100-8 Series 0.8A Sensitive SCRs**

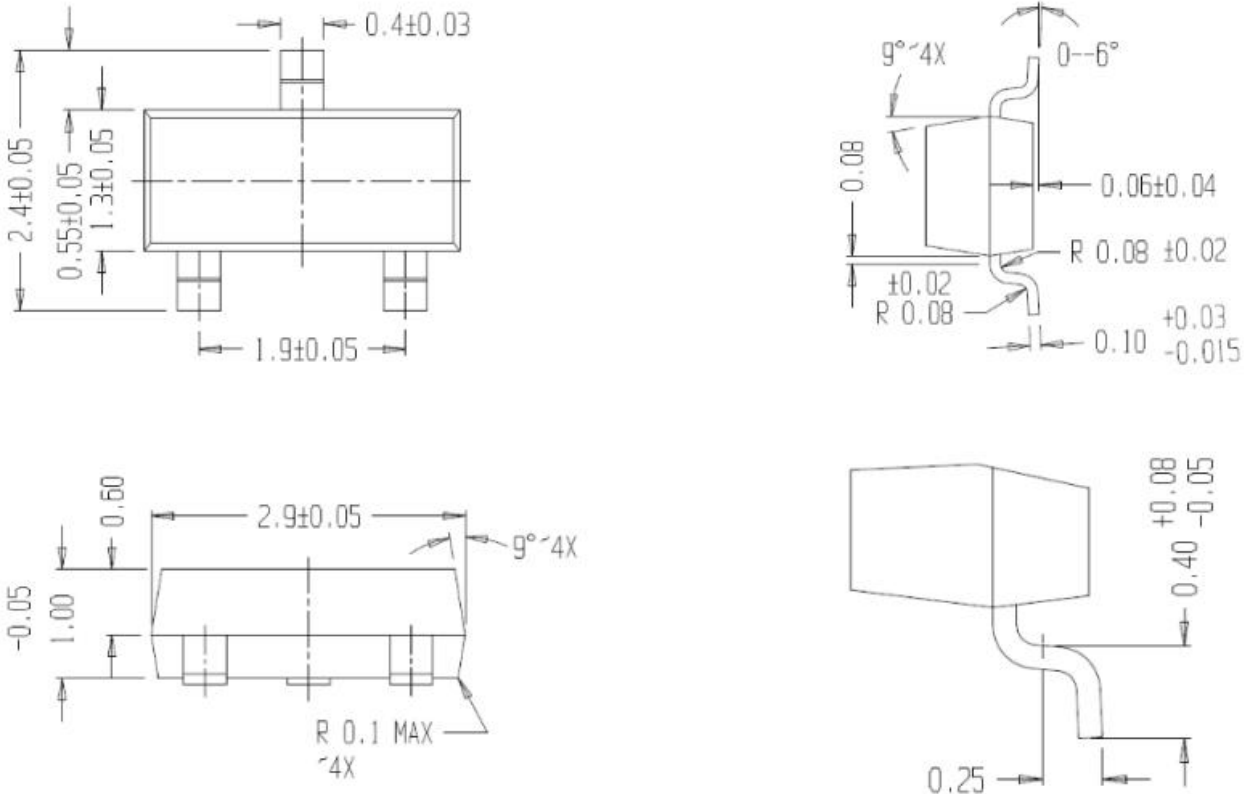

SOT-23

**FIG.1:** Maximum power dissipation versus RMS on-state current

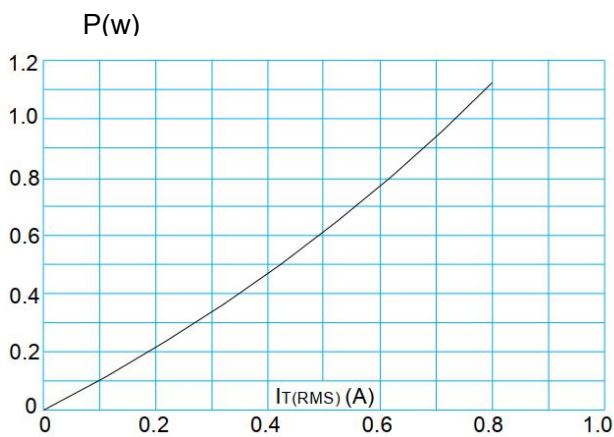

**FIG.2:** RMS on-state current versus case temperature

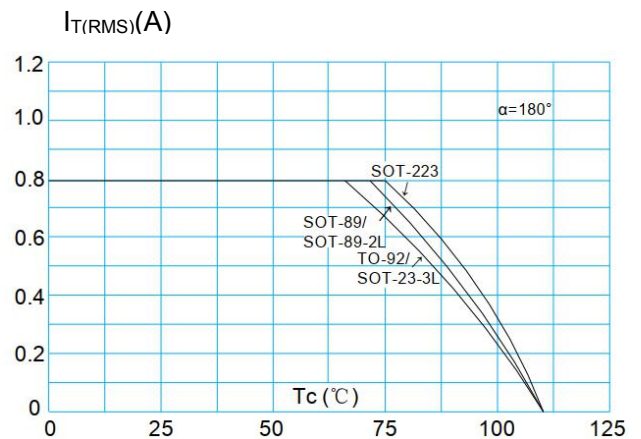



**Jiangsu Weida Semiconductor Co., Ltd.**  
**MCR100-8 Series 0.8A Sensitive SCRs**

**FIG.3:** Surge peak on-state current versus number of cycles

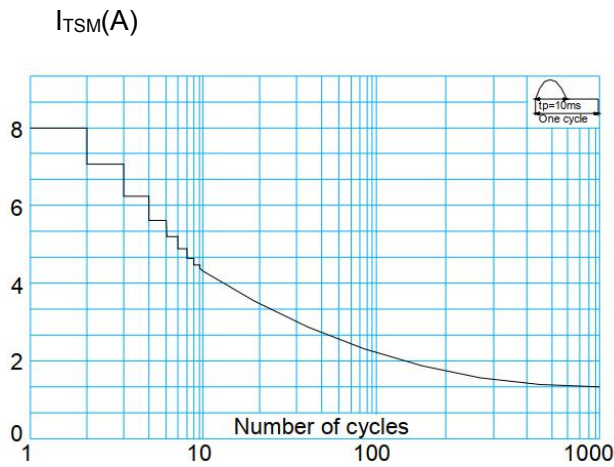

**FIG.5:** Non-repetitive surge peak on-state current for a sinusoidal pulse with width  $t_p < 20\text{ms}$ , and corresponding value of  $I^2t$  ( $di/dt < 50\text{A}/\mu\text{s}$ )

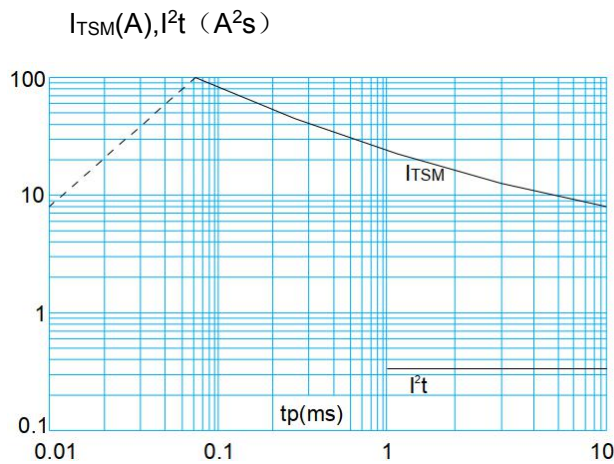

**FIG.4:** On-state characteristics (maximum values)

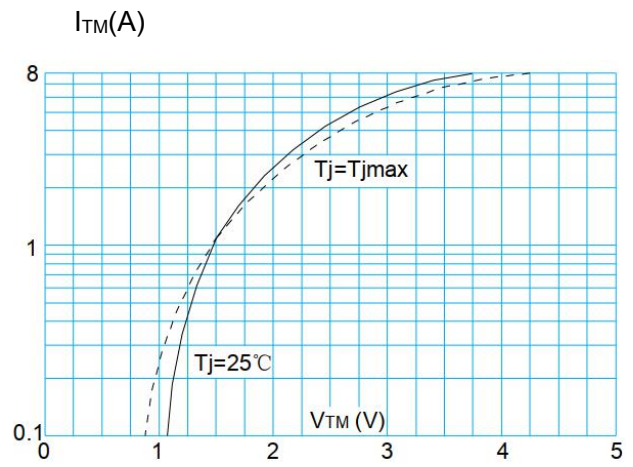

**FIG.6:** Relative variations of gate trigger current, holding current and latching current versus junction temperature

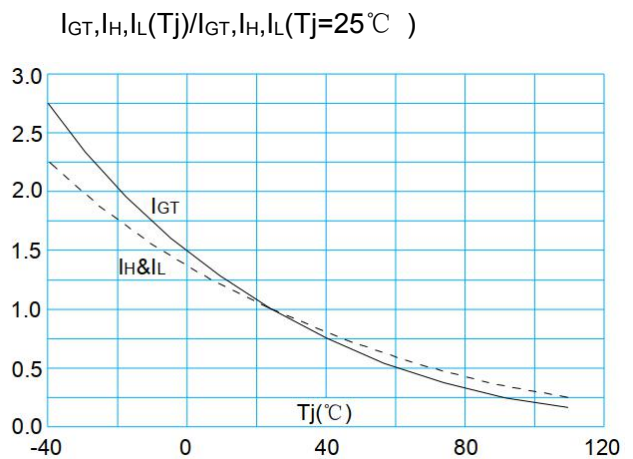



**Jiangsu Weida Semiconductor Co., Ltd.**  
**MCR100-8 Series 0.8A Sensitive SCRs**

---

Information furnished in this document is believed to be accurate and reliable. However, Jiangsu Weida Semiconductor Co., Ltd assumes no responsibility for the consequences of use without consideration for such information nor use beyond it.

Information mentioned in this document is subject to change without notice, apart from that when an agreement is signed, Jiangsu Weida Semiconductor Co., Ltd complies with the agreement.

Products and information provided in this document have no infringement of patents. Jiangsu Weida Semiconductor Co., Ltd assumes no responsibility for any infringement of other rights of third parties which may result from the use of such products and information.

## X-ON Electronics

Largest Supplier of Electrical and Electronic Components

*Click to view similar products for [Triacs](#) category:*

*Click to view products by [Weida Semiconductor](#) manufacturer:*

Other Similar products are found below :

[BT137-600-0Q](#) [OT415Q](#) [2N6075A](#) [NTE5688](#) [BTA2008W-800D,135](#) [D31410](#) [QJ8006NH4TP](#) [QJ8010NH5TP](#) [QJ8008NH4TP](#)  
[QJ8006NH4RP](#) [QJ8010RH5TP](#) [QJ8010NH4TP](#) [QJ8006LH4TP](#) [BT136-600,127](#) [BT137B-800,118](#) [BT138-800E,127](#) [BTA140-600,127](#)  
[BTA208-800B,127](#) [BTA225-800B,127](#) [MAC97A6,116](#) [BTA420-800BT,127](#) [BTA201W-800E,115](#) [BTA212B-800B,118](#) [MCR100-8](#) [100-8](#)  
[BT131S](#) [MCR100-6](#) [MCR100-8](#) [BT136S-800E](#) [BT134S-600E](#) [BT151-650R](#) [BT136-800E](#) [BTA12-800B](#) [BT138S-800E](#) [MAC97A8](#)  
[BT137S-800E](#) [BT169-23](#) [BT131-89-2L](#) [MAC97A6-23-3L](#) [BT169-89-2L](#) [BT139-800E](#) [MCR100-8](#) [BT169-MS](#) [MCR100-8](#) [MCR100-6](#)  
[BTA408X-1000C0T,127](#) [ACT108-800EQP](#) [BTA201-800ER,116](#) [T810](#) [2P4M](#) [BT137-600E](#)