



Jiangsu Weida Semiconductor Co., Ltd.

T16**H 16A High Junction Temperature Triacs

DESCRIPTION:

T16**H triacs of high junction temperature with high dv/dt rate with strong resistance to electromagnetic interference provide high ability to withstand the shock loading of large current. They are especially recommended for use on inductive load and high environment temperature condition.

MAIN FEATURES:

symbol	value	unit
$I_{T(RMS)}$	16.0	A
V_{DRM}/V_{RRM}	800/1000	V

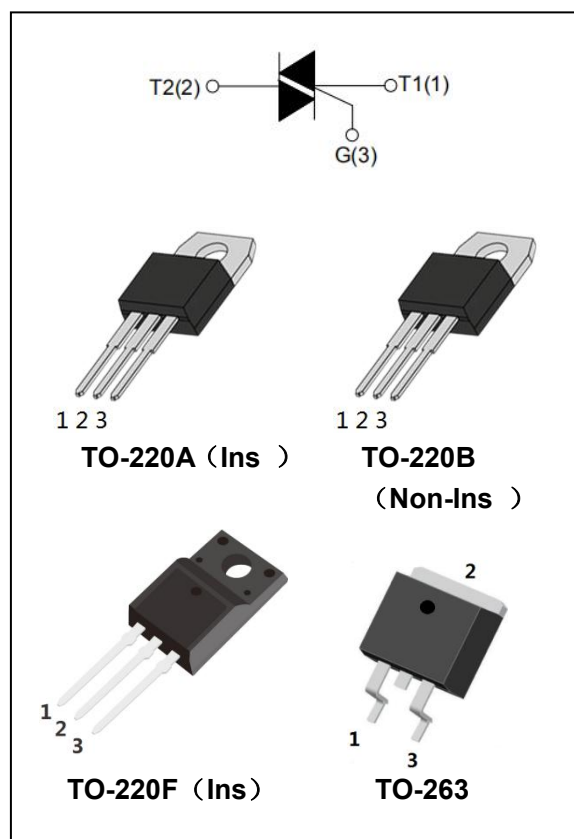

ABSOLUTE MAXIMUM RATINGS:

Parameter	Symbol	Value	Unit
Storage junction temperature range	T_{stg}	-40~150	°C
Operating junction temperature range	T_j	-40~150	°C
Repetitive peak off-state voltage ($T_j=25^\circ\text{C}$)	V_{DRM}	800/1000	V
Repetitive peak reverse voltage ($T_j=25^\circ\text{C}$)	V_{RRM}	800/1000	V
RMS on-state current	$I_{T(RMS)}$	16	A
Non repetitive surge peak on-state current (full cycle, F=50Hz)	I_{TSM}	160	A
I^2t value for fusing ($t_p=10\text{ms}$)	I^2t	128	A^2s
Critical rate of rise of on-state current ($I_G=2 \times I_{GT}$)	di/dt	50	$\text{A}/\mu\text{s}$
Peak gate current	I_{GM}	4	A



Jiangsu Weida Semiconductor Co., Ltd.

T16**H 16A High Junction Temperature Triacs

Average gate power dissipation	$P_{G(AV)}$	1	W
Peak gate power	P_{GM}	5	W

ELECTRICAL CHARACTERISTICS ($T_j=25^\circ\text{C}$ unless otherwise specified)

Parameter	Test Condition	Quadrant		Value				Unit
				T1610	T1620	T1635	T1650	
I_{GT}	$V_D=12V,$ $R_L=33\Omega$	I - II -III	MAX	10	20	35	50	mA
V_{GT}				1.5				V
V_{GD}	$V_D=V_{DRM}$	I - II -III	MIN	0.2				V
I_H	$I_T=100\text{mA}$		MAX	20	30	45	60	mA
I_L	$I_G=1.2I_{GT}$	I -III	MAX	25	40	50	70	mA
		II		35	55	70	90	
dV/dt	$V_D=2/3V_{DRM}$ $T_j=125^\circ\text{C}$ Gate open		MIN	200	500	1000	1500	V/ μs

STATIC CHARACTERISTICS

Symbol	Test Condition			Value	Unit	
V_{TM}	$I_{TM}=22.5A$	$t_p=380\mu\text{s}$	$T_j=25^\circ\text{C}$	MAX	1.5	V
I_{DRM} I_{RRM}	$V_{DRM}=V_{RRM}$		$T_j=25^\circ\text{C}$	MAX	5	μA
			$T_j=125^\circ\text{C}$		1	mA

THERMAL RESISTANCES

Symbol	Test Condition		Value	Unit
$R_{th(j-c)}$	junction to case(AC)	TO-220A(Ins)	2.1	$^\circ\text{C/W}$
		TO-220B(Non-Ins)	1.3	
		TO-220F(Ins)	2.3	
		TO-263	2.4	



Jiangsu Weida Semiconductor Co., Ltd.

T16**H 16A High Junction Temperature Triacs

ORDERING INFORMATION

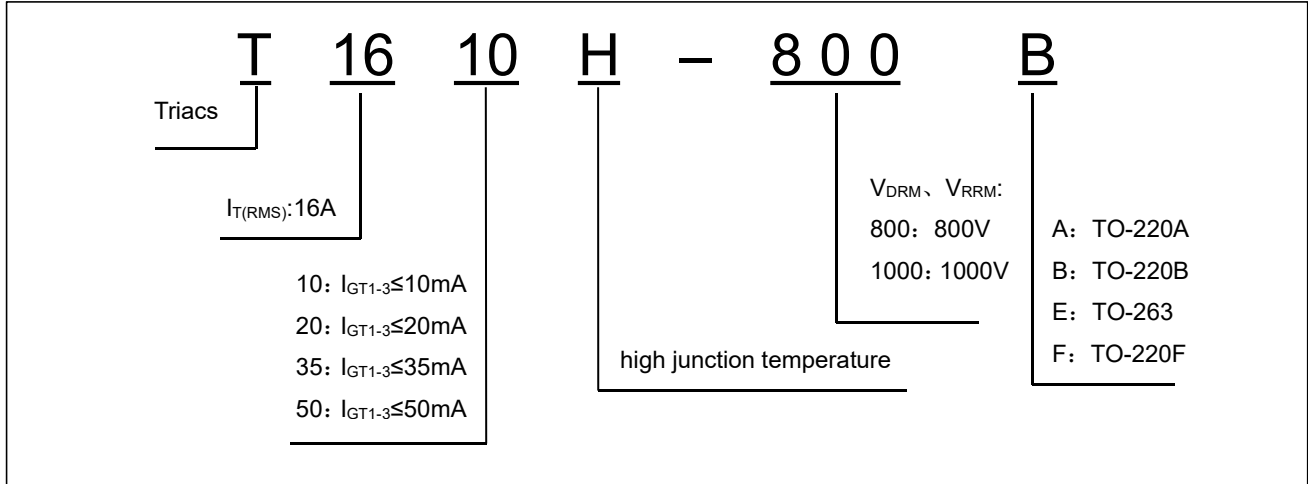

PACKAGE MECHANICAL DATA

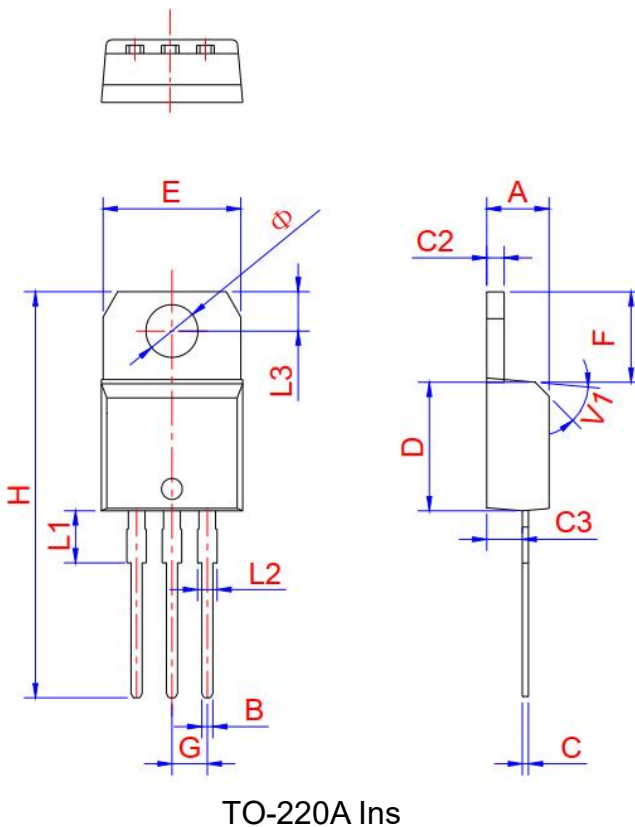

Ref.	Dimensions					
	Millimeters			Inches		
	Min.	Typ.	Max.	Min.	Typ.	Max.
A	4.4	4.47	4.6	0.173	0.176	0.181
B	0.61		0.88	0.024		0.035
C	0.46	0.50	0.7	0.018	0.02	0.028
C2	1.21	1.27	1.32	0.048	0.050	0.052
C3	2.4		2.72	0.094		0.107
D	8.6		9.7	0.339		0.382
E	9.8		10.4	0.386		0.409
F	6.55		6.95	0.258		0.274
G		2.54			0.1	
H	28		29.8	1.102		1.173
L1		3.75			0.148	
L2	1.14		1.7	0.045		0.067
L3	2.65		2.95	0.104		0.116
V1		45°			45°	
Φ	3.7	3.75	3.8	0.145	0.147	0.149



Jiangsu Weida Semiconductor Co., Ltd.

T16**H 16A High Junction Temperature Triacs

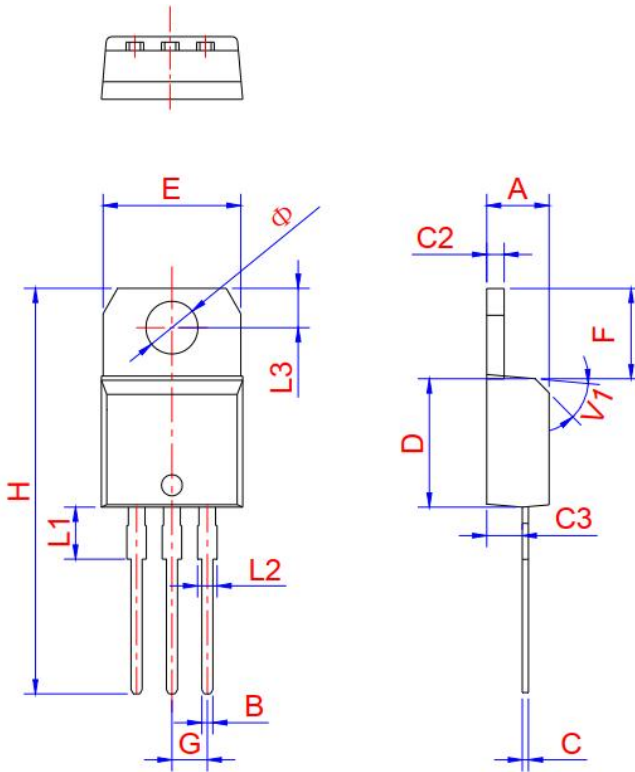

TO-220B Non-Ins

Ref.	Dimensions					
	Millimeters			Inches		
	Min.	Typ.	Max.	Min.	Typ.	Max.
A	4.4	4.47	4.6	0.173	0.176	0.181
B	0.61		0.88	0.024		0.035
C	0.46	0.50	0.7	0.018	0.02	0.028
C2	1.21	1.27	1.32	0.048	0.050	0.052
C3	2.4		2.72	0.094		0.107
D	8.6		9.7	0.339		0.382
E	9.8		10.4	0.386		0.409
F	6.55		6.95	0.258		0.274
G		2.54			0.1	
H	28		29.8	1.102		1.173
L1		3.75			0.148	
L2	1.14		1.7	0.045		0.067
L3	2.65		2.95	0.104		0.116
V1		45°			45°	
Φ	3.7	3.75	3.8	0.145	0.147	0.149

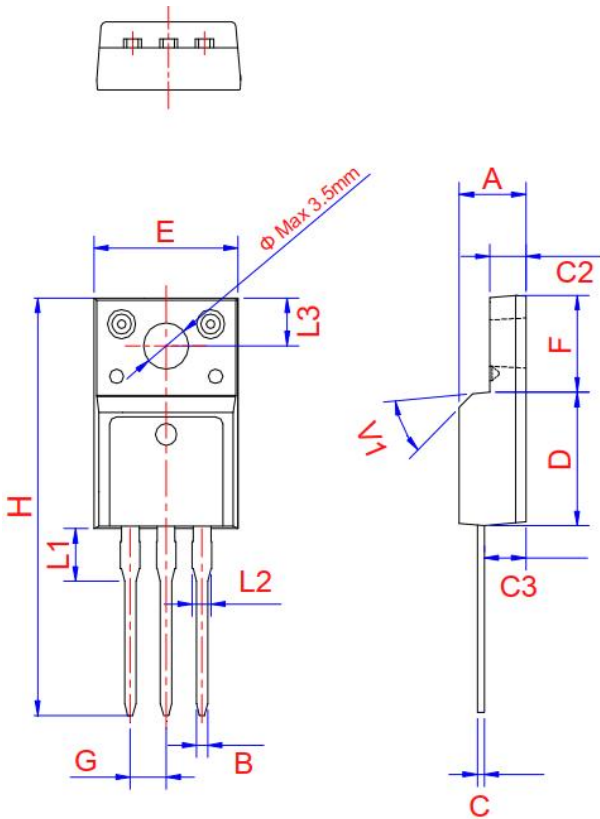

TO-220F Ins

Ref.	Dimensions					
	Millimeters			Inches		
	Min.	Typ.	Max.	Min.	Typ.	Max.
A	4.5		4.9	0.177		0.193
B	0.74	0.8	0.83	0.029	0.031	0.033
C	0.47		0.65	0.019		0.026
C2	2.45		2.75	0.096		0.108
C3	2.6		3	0.102		0.118
D	8.8		9.3	0.346		0.366
E	9.8		10.4	0.386		0.41
F	6.4		6.8	0.252		0.268
G		2.54			0.1	
H	28		29.8	1.102		1.173
L1		3.63			0.148	
L2	1.14		1.7	0.045		0.067
L3	2.65	3.3	0		0.13	0.116
V1		45°			45°	



Jiangsu Weida Semiconductor Co., Ltd.

T16**H 16A High Junction Temperature Triacs

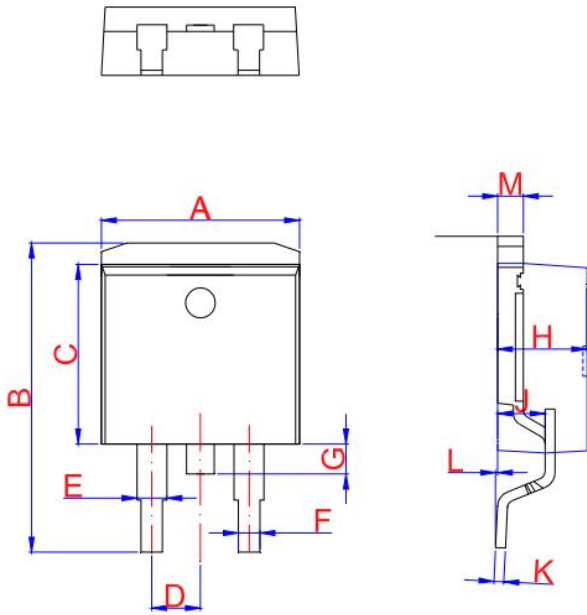

TO-263

Ref.	Dimensions					
	Millimeters			Inches		
	Min.	Typ.	Max.	Min.	Typ.	Max.
A	9.9		10.3	0.390		0.406
B	14.7		15.8	0.579		0.622
C	8.5		8.9	0.370		0.378
D		2.54			0.100	
E	1.20		1.40	0.047		0.055
F	0.75		0.85	0.029		0.033
G			1.75			0.069
H	4.40	4.60	4.80	0.173	0.181	0.189
J	2.40	2.60	2.80	0.094	0.102	0.110
L	0	0.1	0.25	0	0.004	0.010
M	1.17	1.27	1.37	0.046	0.05	0.054

FIG.1: Maximum power dissipation versus RMS on-state current

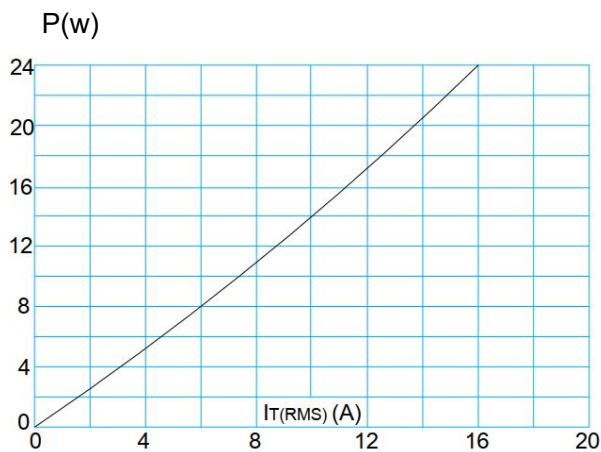
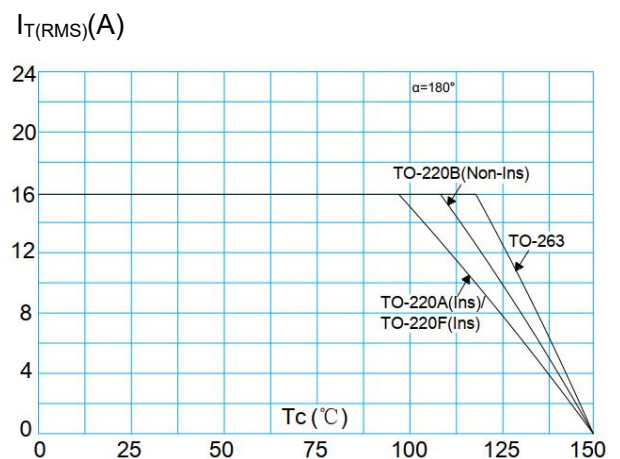

FIG.2: RMS on-state current versus case temperature





Jiangsu Weida Semiconductor Co., Ltd.

T16**H 16A High Junction Temperature Triacs

FIG.3: Surge peak on-state current versus number of cycles

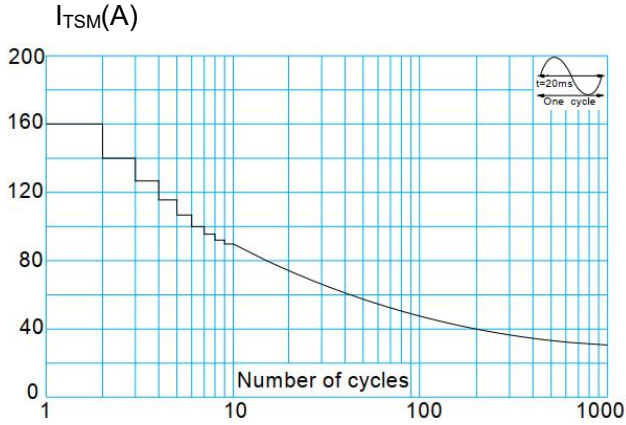

FIG.4: On-state characteristics (maximum values)

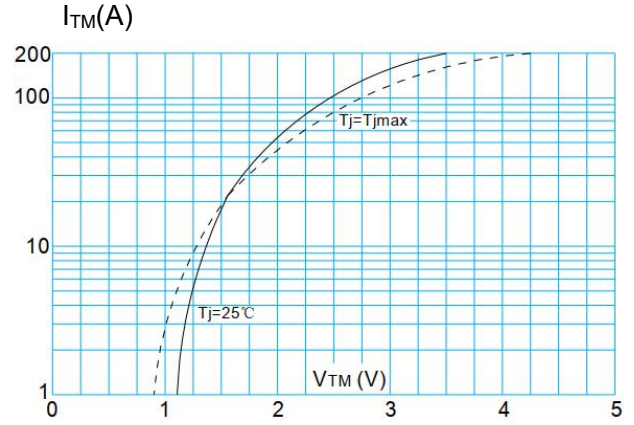

FIG.5: Non-repetitive surge peak on-state current for a sinusoidal pulse with width $t_p < 20\text{ms}$, and corresponding value of I^2t (I - II - III: $dI/dt < 50\text{A}/\mu\text{s}$; IV: $dI/dt < 10\text{A}/\mu\text{s}$)

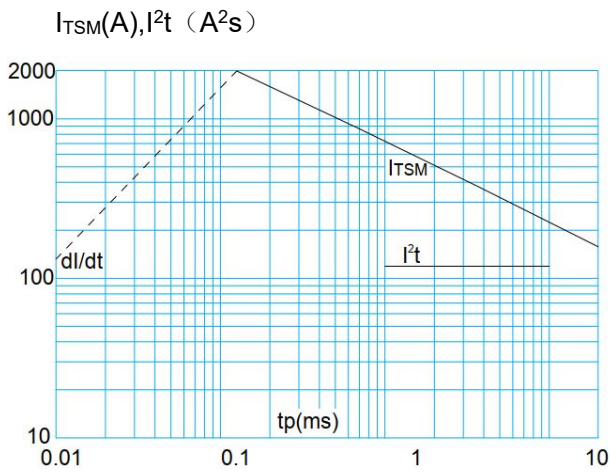
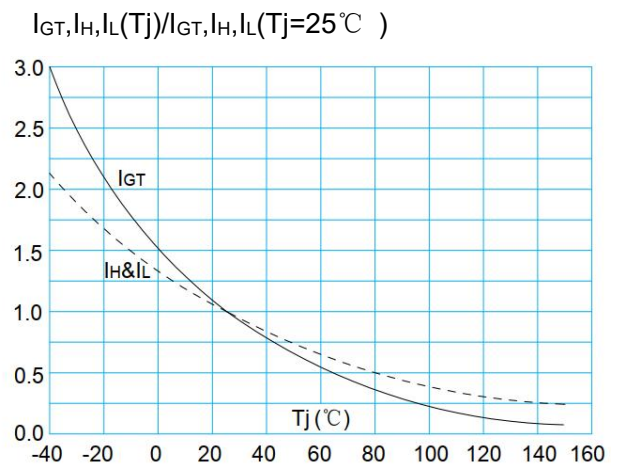

FIG.6: Relative variations of gate trigger current, holding current and latching current versus junction temperature





Jiangsu Weida Semiconductor Co., Ltd.
T16H 16A High Junction Temperature Triacs**

Information furnished in this document is believed to be accurate and reliable. However, Jiangsu Weida Semiconductor Co., Ltd assumes no responsibility for the consequences of use without consideration for such information nor use beyond it.

Information mentioned in this document is subject to change without notice, apart from that when an agreement is signed, Jiangsu Weida Semiconductor Co., Ltd complies with the agreement.

Products and information provided in this document have no infringement of patents. Jiangsu Weida Semiconductor Co., Ltd assumes no responsibility for any infringement of other rights of third parties which may result from the use of such products and information.

X-ON Electronics

Largest Supplier of Electrical and Electronic Components

Click to view similar products for [SCRs category](#):

Click to view products by [Weida Semiconductor manufacturer](#):

Other Similar products are found below :

[NTE5428](#) [T1500N16TOF VT](#) [T830N16TOF](#) [T880N14TOF](#) [T880N16TOF](#) [TT162N16KOF-A](#) [TT330N16AOF](#) [VS-22RIA20](#) [VS-2N685](#) [VS-80RIA120PBF](#) [BT152-400R/B](#) [T1190N16TOF VT](#) [T830N14TOF](#) [TT250N12KOF-K](#) [NTE5427](#) [VS-180RKI40](#) [T2160N28TOF VT](#) [VS-22RIA100](#) [VS-16RIA40](#) [GA301A](#) [2N1776A](#) [NTE5481](#) [NTE5519](#) [NTE5553](#) [NTE5570](#) [NTE5576](#) [NTE5584](#) [NTE5589](#) [NTE5592](#) [NTE6418](#) [NTE6419](#) [T3160N16TOF VT](#) [VS-22RIA80](#) [T1500N18TOF VT](#) [T3160N18TOF VT](#) [TN1610H-6I](#) [K1010MA650](#) [BT151-500RT,127](#) [BTW69-800RG](#) [T3035H-800B](#) [T1635H-800B](#) [TS420-600T-JSM](#) [BTB12-800CW](#) [BT136](#) [BTA41-800B](#) [BTW69-1200B](#) [C106M](#) [BTA12-800CW](#) [BTB08-800CW](#) [BTB16-600B](#)