



Jiangsu Weida Semiconductor Co., Ltd.

T30**H 30A High Junction Temperature Triacs

DESCRIPTION:

T30**H triacs of high junction temperature with high dv/dt rate with strong resistance to electromagnetic interference provide high ability to withstand the shock loading of large current. They are especially recommended for use on inductive load and high environment temperature condition.

MAIN FEATURES:

symbol	value	unit
$I_{T(RMS)}$	30.0	A
V_{DRM}/V_{RRM}	600/800	V

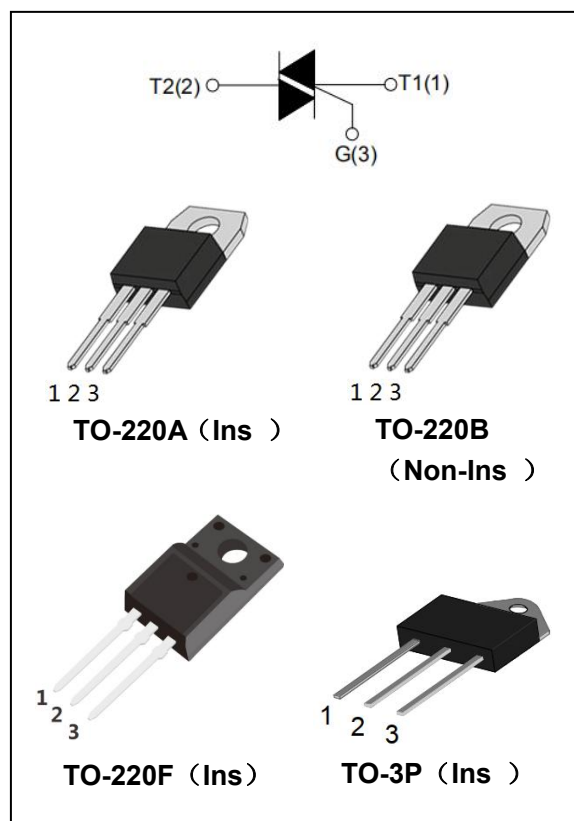

ABSOLUTE MAXIMUM RATINGS:

Parameter	Symbol	Value	Unit
Storage junction temperature range	T_{stg}	-40~150	°C
Operating junction temperature range	T_j	-40~150	°C
Repetitive peak off-state voltage ($T_j=25^\circ\text{C}$)	V_{DRM}	600/800	V
Repetitive peak reverse voltage ($T_j=25^\circ\text{C}$)	V_{RRM}	600/800	V
RMS on-state current	$I_{T(RMS)}$	30	A
Non repetitive surge peak on-state current (full cycle, F=50Hz)	I_{TSM}	300	A
I^2t value for fusing ($t_p=10\text{ms}$)	I^2t	340	A^2s
Critical rate of rise of on-state current ($I_G=2 \times I_{GT}$)	di/dt	50	$\text{A}/\mu\text{s}$
Peak gate current	I_{GM}	4	A



Jiangsu Weida Semiconductor Co., Ltd.

T30**H 30A High Junction Temperature Triacs

Average gate power dissipation	$P_{G(AV)}$	1	W
Peak gate power	P_{GM}	10	W

ELECTRICAL CHARACTERISTICS ($T_j=25^\circ\text{C}$ unless otherwise specified)

Parameter	Test Condition	Quadrant		Value		Unit
				T3035	T3050	
I_{GT}	$V_D=12\text{V}$, $R_L=33\Omega$	I - II -III	MAX	35	50	mA
V_{GT}				1.5		V
V_{GD}	$V_D=V_{DRM}$	I - II -III	MIN	0.2		V
I_H	$I_T=100\text{mA}$		MAX	45	60	mA
I_L	$I_G=1.2I_{GT}$	I -III	MAX	50	70	mA
		II		70	90	
dV/dt	$V_D=2/3V_{DRM}$ $T_j=150^\circ\text{C}$ Gate open		MIN	500	1000	V/ μs

STATIC CHARACTERISTICS

Symbol	Test Condition			Value	Unit
V_{TM}	$I_{TM}=35\text{A}$ $t_p=380\mu\text{s}$	$T_j=25^\circ\text{C}$	MAX	1.5	V
I_{DRM} I_{RRM}	$V_{DRM}=V_{RRM}$	$T_j=25^\circ\text{C}$	MAX	10	μA
		$T_j=125^\circ\text{C}$		3	mA

THERMAL RESISTANCES

Symbol	Test Condition		Value	Unit
$R_{th(j-c)}$	junction to case(AC)	TO-220A(Ins)	1.7	$^\circ\text{C/W}$



Jiangsu Weida Semiconductor Co., Ltd.

T30**H 30A High Junction Temperature Triacs

ORDERING INFORMATION

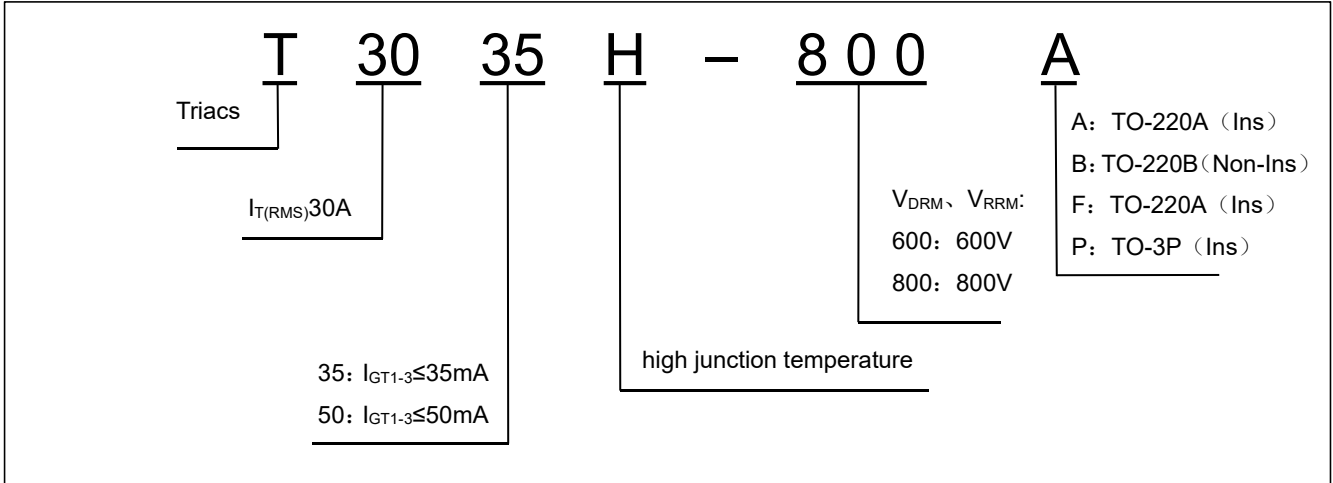

PACKAGE MECHANICAL DATA

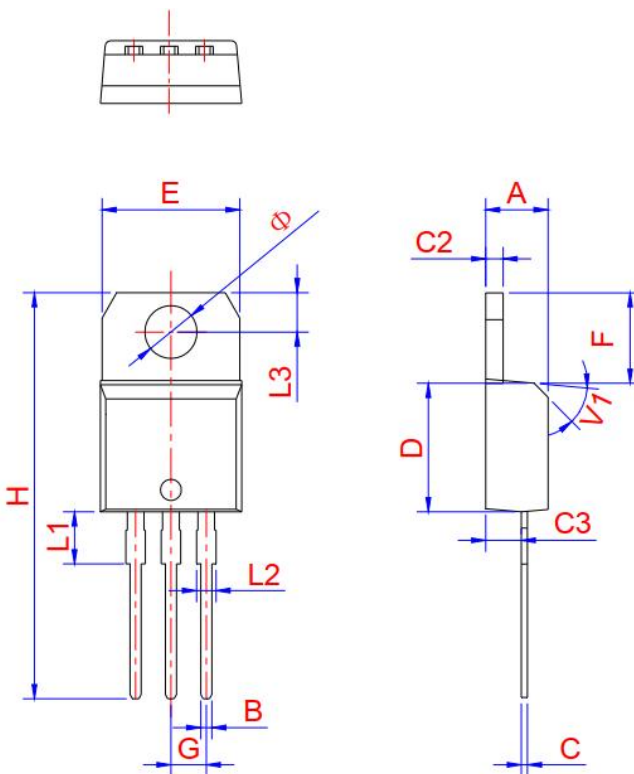

TO-220A Ins

Ref.	Dimensions					
	Millimeters			Inches		
	Min.	Typ.	Max.	Min.	Typ.	Max.
A	4.4	4.47	4.6	0.173	0.176	0.181
B	0.61		0.88	0.024		0.035
C	0.46	0.50	0.7	0.018	0.02	0.028
C2	1.21	1.27	1.32	0.048	0.050	0.052
C3	2.4		2.72	0.094		0.107
D	8.6		9.7	0.339		0.382
E	9.8		10.4	0.386		0.409
F	6.55		6.95	0.258		0.274
G		2.54			0.1	
H	28		29.8	1.102		1.173
L1		3.75			0.148	
L2	1.14		1.7	0.045		0.067
L3	2.65		2.95	0.104		0.116
V1		45°			45°	
Φ	3.7	3.75	3.8	0.145	0.147	0.149



Jiangsu Weida Semiconductor Co., Ltd.

T30**H 30A High Junction Temperature Triacs

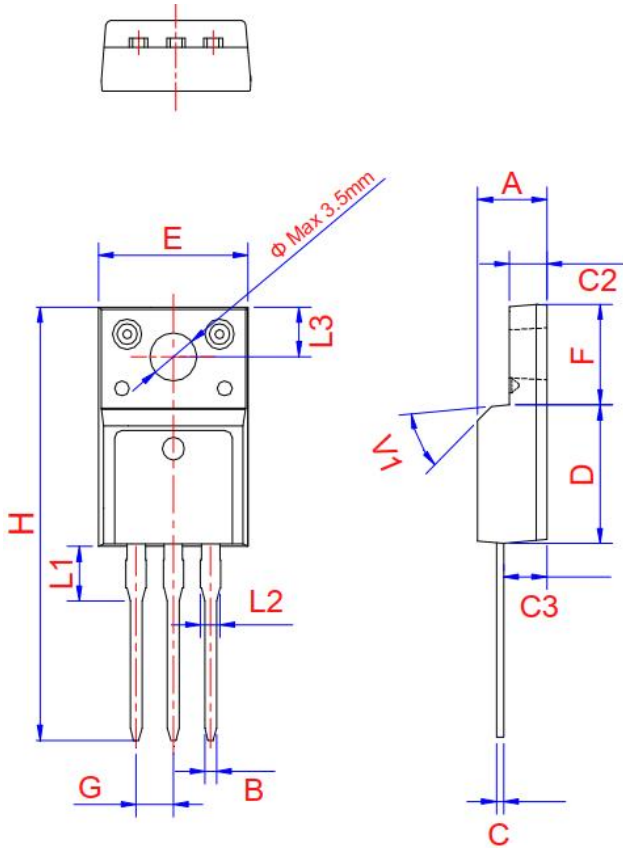

TO-220F Ins

Ref.	Dimensions					
	Millimeters			Inches		
	Min.	Typ.	Max.	Min.	Typ.	Max.
A	4.5		4.9	0.177		0.193
B	0.74	0.8	0.83	0.029	0.031	0.033
C	0.47		0.65	0.019		0.026
C2	2.45		2.75	0.096		0.108
C3	2.6		3	0.102		0.118
D	8.8		9.3	0.346		0.366
E	9.8		10.4	0.386		0.41
F	6.4		6.8	0.252		0.268
G		2.54			0.1	
H	28		29.8	1.102		1.173
L1		3.63			0.148	
L2	1.14		1.7	0.045		0.067
L3	2.65	3.3	0		0.13	0.116
V1		45°			45°	

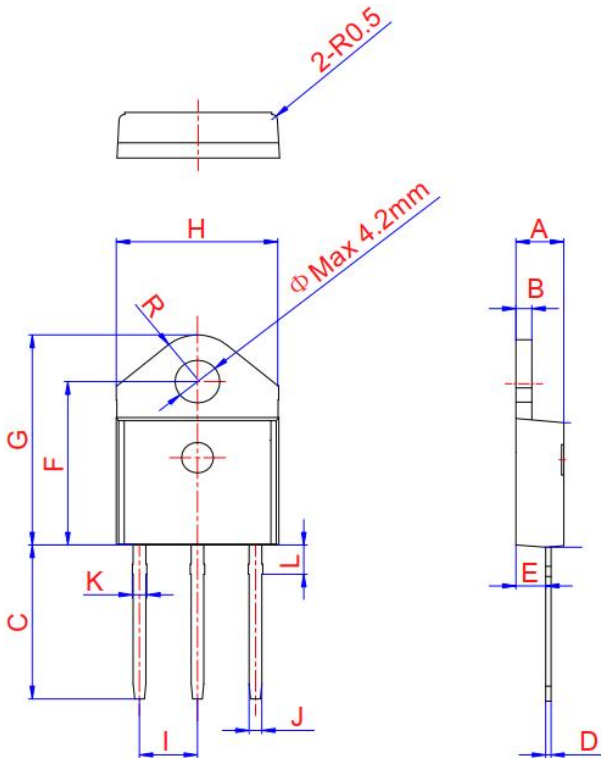

TO-3P Ins

Ref.	Dimensions					
	Millimeters			Inches		
	Min.	Typ.	Max.	Min.	Typ.	Max.
A	4.40	4.50	4.60	0.173	0.177	0.181
B	1.45	1.50	1.55	0.057	0.059	0.061
C	14.35		15.60	0.565		0.614
D	0.50	0.60	0.70	0.02	0.024	0.028
E	2.70	2.80	2.90	0.106	0.110	0.114
F	15.80		16.50	0.622		0.650
G	20.40		21.10	0.803		0.831
H	15.10	15.30	15.50	0.594	0.602	0.610
I	5.40		5.65	0.213		0.222
J	1.10		1.40	0.043		0.055
K	1.35		1.50	0.053		0.059
L	2.80	2.90	3.00	0.110	0.114	0.118
R		4.35			0.171	



Jiangsu Weida Semiconductor Co., Ltd.

T30**H 30A High Junction Temperature Triacs

FIG.1: Maximum power dissipation versus RMS on-state current
 $P(w)$

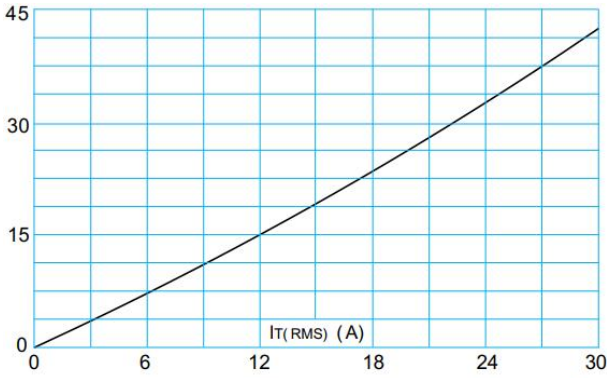

FIG.3: Surge peak on-state current versus number of cycles

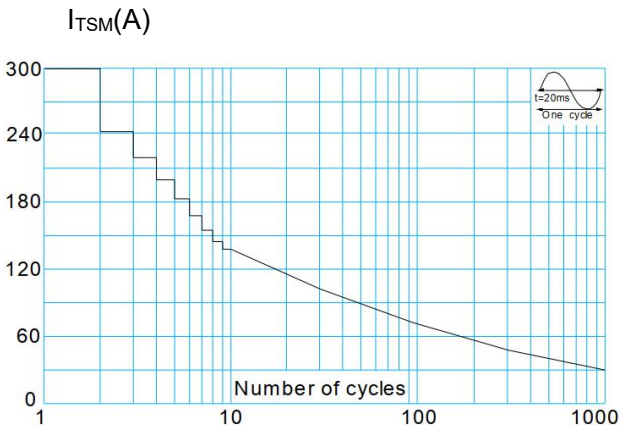

FIG.5: Non-repetitive surge peak on-state current for a sinusoidal pulse with width $t_p < 20ms$, and corresponding value of I^2t ($I - II - III: di/dt < 50A/\mu s; IV: di/dt < 10A/\mu s$)

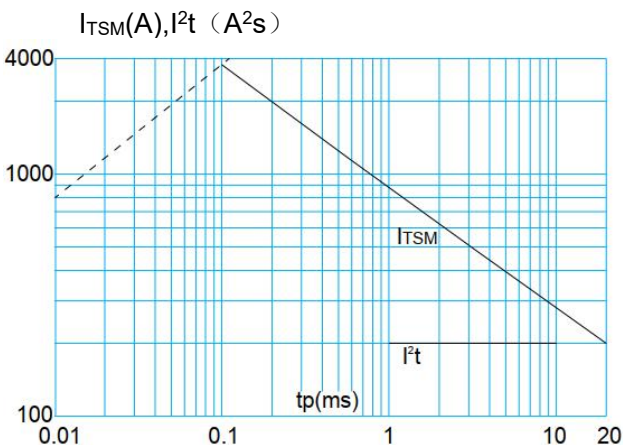

FIG.2: RMS on-state current versus case temperature
 $I_{T(RMS)}(A)$

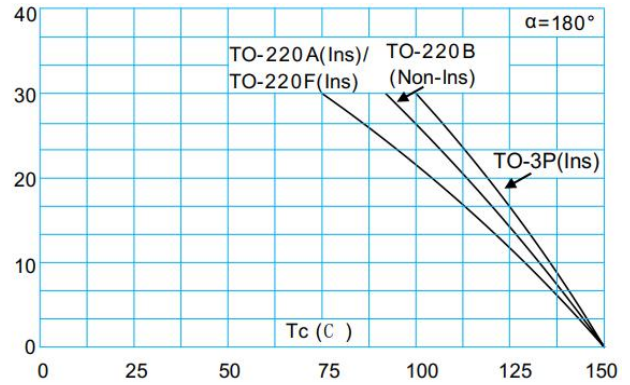

FIG.4: On-state characteristics (maximum values)

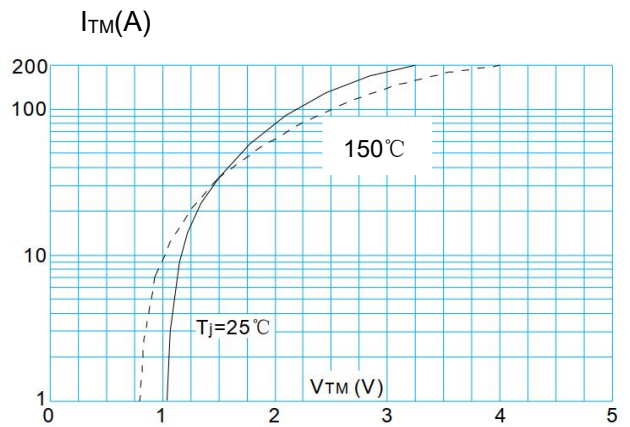
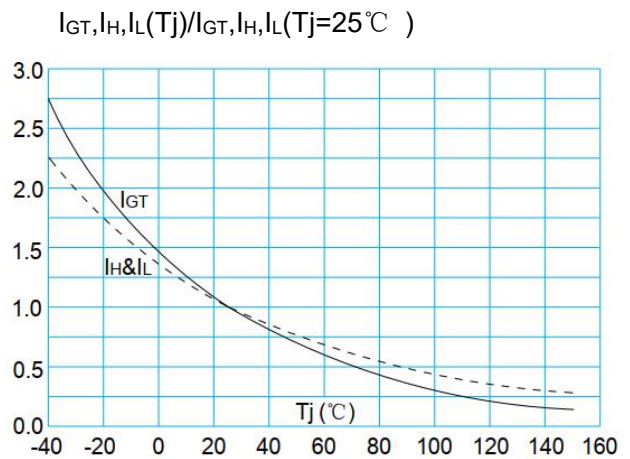

FIG.6: Relative variations of gate trigger current, holding current and latching current versus junction temperature





Jiangsu Weida Semiconductor Co., Ltd.
T30H 30A High Junction Temperature Triacs**

Information furnished in this document is believed to be accurate and reliable. However, Jiangsu Weida Semiconductor Co., Ltd assumes no responsibility for the consequences of use without consideration for such information nor use beyond it.

Information mentioned in this document is subject to change without notice, apart from that when an agreement is signed, Jiangsu Weida Semiconductor Co., Ltd complies with the agreement.

Products and information provided in this document have no infringement of patents. Jiangsu Weida Semiconductor Co., Ltd assumes no responsibility for any infringement of other rights of third parties which may result from the use of such products and information.

X-ON Electronics

Largest Supplier of Electrical and Electronic Components

Click to view similar products for [SCRs](#) category:

Click to view products by [Weida Semiconductor](#) manufacturer:

Other Similar products are found below :

[NTE5428](#) [T1500N16TOF VT](#) [T830N16TOF](#) [T880N14TOF](#) [T880N16TOF](#) [TT162N16KOF-A](#) [TT330N16AOF](#) [VS-22RIA20](#) [VS-2N685](#) [VS-80RIA120PBF](#) [BT152-400R/B](#) [T1190N16TOF VT](#) [T830N14TOF](#) [TT250N12KOF-K](#) [NTE5427](#) [VS-180RKI40](#) [T2160N28TOF VT](#) [VS-22RIA100](#) [VS-16RIA40](#) [GA301A](#) [2N1776A](#) [NTE5481](#) [NTE5519](#) [NTE5553](#) [NTE5570](#) [NTE5576](#) [NTE5584](#) [NTE5589](#) [NTE5592](#) [NTE6418](#) [NTE6419](#) [T3160N16TOF VT](#) [VS-22RIA80](#) [T1500N18TOF VT](#) [T3160N18TOF VT](#) [TN1610H-6I](#) [K1010MA650](#) [BT151-500RT,127](#) [BTW69-800RG](#) [T3035H-800B](#) [T1635H-800B](#) [TS420-600T-JSM](#) [BTB12-800CW](#) [BT136](#) [BTA41-800B](#) [BTW69-1200B](#) [C106M](#) [BTA12-800CW](#) [BTB08-800CW](#) [BTB16-600B](#)