



WDC reserves the right to make changes at any time without notice in order to improve design and supply the best possible product. Information contained herein is provided gratuitously and without liability, to any user. Reasonable efforts have been made to verify the accuracy of the information but no guarantee whatsoever is given as to the accuracy or as to its applicability to particular uses. In every instance, it must be the responsibility of the user to determine the suitability of the products for each application. WDC products are not authorized for use as critical components in life support devices or systems. Nothing contained herein shall be construed as a recommendation to use any product in violation of existing patents or other rights of third parties. The sale of any WDC product is subject to all WDC Terms and Conditions of Sales and Sales Policies, copies of which are available upon request.

Copyright (C) 1981-2014 by The Western Design Center, Inc. All rights reserved, including the right of reproduction in whole or in part in any form.



DOCUMENT REVISION HISTORY

Version	Date	Author	Description
0.1	1-Jun-13	David Gray	Initial Document Entry
0.2	24-Jan-14	David Gray	Updated latest REV B Board Information
1.0	02-Dec-14	David Gray	Updated Quick reference guide for ACIA



Contents

- DOCUMENT REVISION HISTORY 2
- 1. Introduction and Features 4
 - 1.1 Feature List..... 4
 - 1.2 Functional Block Diagram 4
 - 1.3 Board Diagram..... 5
 - 1.4 W65C02SXB QUICK REFERENCE GUIDE 6
- 2. Connector Descriptions 7
 - 2.1 XBus Port (J1) 7
 - 2.2 PIA Port (J2)..... 7
 - 2.3 VIA Port (J3)..... 7
 - 2.4 ACIA Port (J4) 7
 - 2.5 USB TIDE Port (J5)..... 7



1. Introduction and Features

The W65C02SXB is an educational and industrial strength Engineering Development System based around the world renowned W65C02S 8-bit microprocessor. With its vast I/O provided by the on board W65C22 VIA, W65C21 PIA, and W65C51 ACIA peripheral ports the 02SXB provides the user with easy access to the vast flexibility in design possibilities using our Addressable Register Architecture (ARA). The addition of the XBus allows for expansion beyond the standard on board peripherals by providing full Data Bus, Address Bus and Control Signal access.

1.1 Feature List

- W65C02S MPU running at 8MHz. Refer to the [W65C02S Datasheet](#) for details on the processor.
- 2 x W65C22N VIA(1/2) - One for USB FIFO Interface and one VIA Expansion Port
- 1 x W65C21 PIA with PIA Expansion Port
- 1 x W65C51N ACIA with ACIA Expansion Port
- 1 x XBus02 Connector with full address, data and control lines of the processor and 3 external chip selects
- 1 x 128Kbytes FLASH ROM (32PLCC Socket) mapped as upper 32KB of Memory Map with overlays off of 2 IO pins from W65C22 TIDE (VIA2) Port
- 1 x 32Kbytes SRAM
- Programming/Debug Interface – FTDI245 FIFO VIA2 (W65C22N) using the onboard ROM Monitor.
- Micro USB Connector – USB Power and Debugging Interface

1.2 Functional Block Diagram

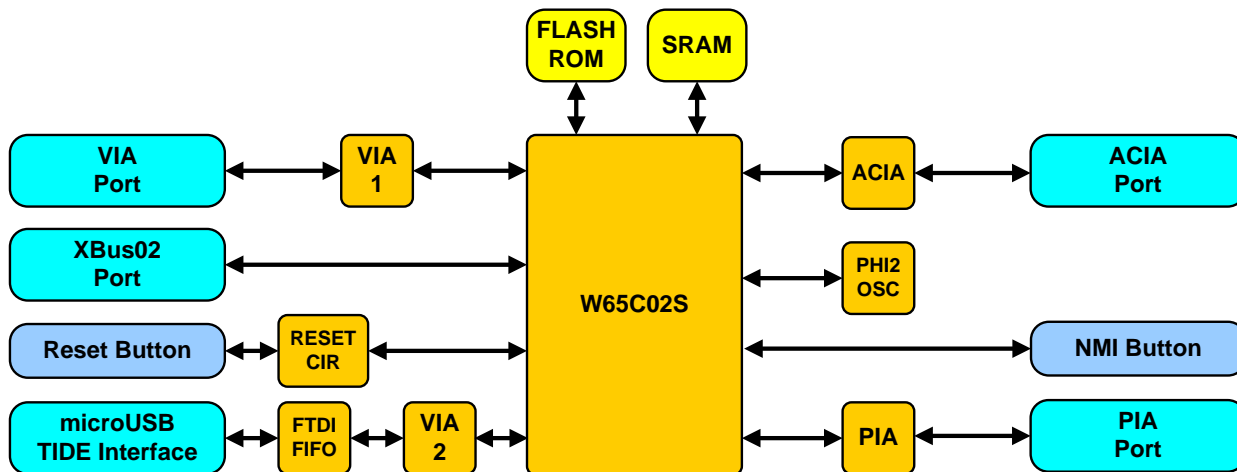

1.3 Board Diagram

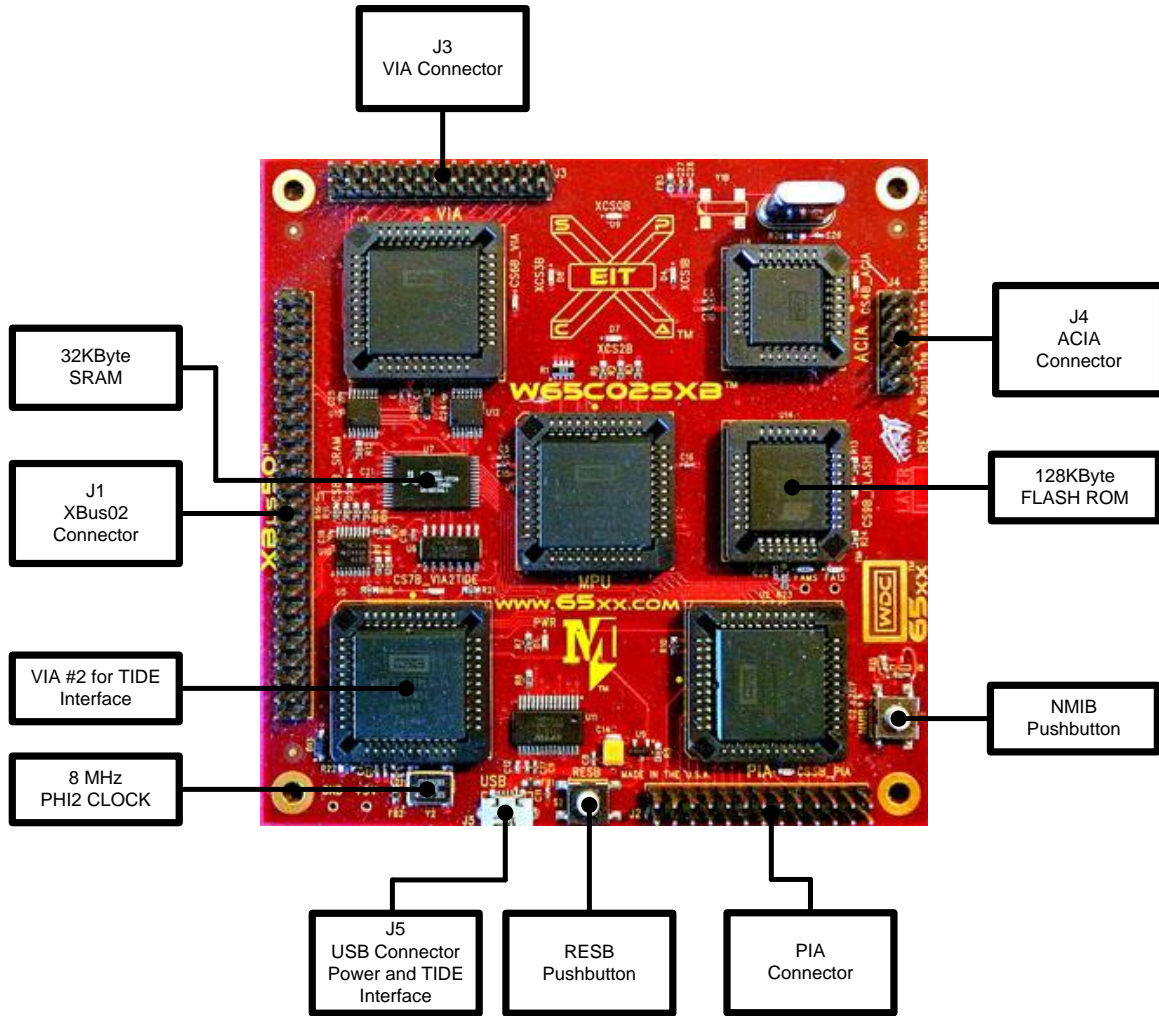

100mm x 100mm PCB



1.4 Quick Reference Guide

W65C02SXB Memory Map				
Start	End	Size	Chip Select	Description
0x8000	0xFFFF	32 KB	CS9B	FLASH ROM (x4, 128KB used with 2 IO pins for overlays)
0x0000	0x7FFF	32 KB	CS8B	SRAM (7FFF-7F00 is Decoded for expansion)
0x7FE0	0x7FFF	32 B	CS7B	VIA-TIDE
0x7FC0	0x7FDF	32 B	CS6B	VIA Port
0x7FA0	0x7FBF	32 B	CS5B	PIA Port
0x7F80	0x7F9F	32 B	CS4B	ACIA Port
0x7F60	0x7F7F	32 B	CS3B	Not Used
0x7F40	0x7F5F	32 B	XCS2B	XBus Chip Select 2
0x7F20	0x7F3F	32 B	XCS1B	XBus Chip Select 1
0x7F00	0x7F1F	32 B	XCS0B	XBus Chip Select 0

J2 – PIA Connector			
Pin	Signal Name	Pin	Signal Name
1	VDD	2	VSS
3	CA1	4	CA2
5	PA0	6	PA1
7	PA2	8	PA3
9	PA4	10	PA5
11	PA6	12	PA7
13	NO CONNECT	14	NO CONNECT
15	CB1	16	CB2
17	PB0	18	PB1
19	PB2	20	PB3
21	PB4	22	PB5
23	PB6	24	PB7
25	VSS	26	VDD

J1 – XBus02 Connector			
Pin	Signal Name	Pin	Signal Name
1	VDD	2	VSS
3	D0	4	D1
5	D2	6	D3
7	D4	8	D5
9	D6	10	D7
11	A0	12	A1
13	A2	14	A3
15	A4	16	A5
17	A6	18	A7
19	A8	20	A9
21	A10	22	A11
23	A12	24	A13
25	A14	26	A15
27	XCS0B	28	XCS1B
29	XCS2B	30	VPB
31	IRQB	32	NMIB
33	RESB	34	MLB
35	SYNC	36	BE
37	RWB	38	PHI2
39	VSS	40	VDD

J3 – VIA Connector			
Pin	Signal Name	Pin	Signal Name
1	VDD	2	VSS
3	CA1	4	CA2
5	PA0	6	PA1
7	PA2	8	PA3
9	PA4	10	PA5
11	PA6	12	PA7
13	NO CONNECT	14	NO CONNECT
15	CB1	16	CB2
17	PB0	18	PB1
19	PB2	20	PB3
21	PB4	22	PB5
23	PB6	24	PB7
25	VSS	26	VDD

J4 – ACIA Connector			
Pin	Signal Name	Pin	Signal Name
1	VDD	2	VSS
3	RTSB	4	DTRB
5	RXD	6	DSRB
7	TXD	8	DCDB
9	CTSB	10	RXC



2. Connector Descriptions

Following are descriptions of main board connectors.

2.1 XBus Port (J1)

The “XBus02” is a 40-pin male connector with the following signals:

- 8 Data Bus lines (D0-D7)
- 16 Address Bus lines (A0-A15; 64 Kbyte space)
- 3 External Chip Select Lines for expansion (XCS0B-XCS2B)
- 9 Control lines (PHI2, RWB, BE, SYNC, MLB, RESB, NMIB, IRQB, VPB)
- 4 Power and Ground - 2x VSS (Pins 2 and 39) and 2x VDD (Pins 1 and 40)

2.2 PIA Port (J2)

The PIA Port Connector is an asynchronous parallel expansion port connected to the W65C21S/N. It is a 26 Pin (2 x 13; .100” spacing) male connector that provides access to the 20 I/Os (8x PA, 8x PB, CA1/2, CB1/2) of the PIA. The remaining pins serve as Power (x2) and Ground pins (x4). See section 1.4 – Quick Reference Guide for a full pin listing. Refer to the [W65C21 Datasheet](#) for detailed information for that chip.

2.3 VIA Port (J3)

The VIA Port Connector is an asynchronous parallel expansion port connected to the W65C22N. It is a 26 Pin (2 x 13; .100” spacing) male connector that provides access to the 20 I/Os (8x PA, 8x PB, CA1/2, CB1/2) of the VIA. The remaining pins serve as Power (Pins 1 and 26) and Ground pins (Pins 2, 13, 14, 35). See section 1.4 – Quick Reference Guide for a full pin listing. Refer to the [W65C22 Datasheet](#) for detailed information for that chip.

2.4 ACIA Port (J4)

The ACIA Port Connector is an asynchronous serial expansion port connected to the W65C51N. It is a 10 Pin (2 x 5; .100” spacing) connector that provides access to the 8 communication signals of the ACIA. Pin 1 is VDD and Pin 2 is VSS. See section 1.4 – Quick Reference Guide for a full pin listing. Refer to the [W65C51 Datasheet](#) for detailed information for that chip.

2.5 Micro USB TIDE Port (J5)

The Micro USB connector is dual purpose. It is the power connector that powers the board. The FTDI chip that interfaces to the connector has been pre-programmed so that when the board is powered from a USB power on a computer, the chip will request 500mA of current from the host machine. The board can also be powered by any USB port that supplies 5V DC. Note that the board does not have a voltage regulator. 5V DC must be supplied. In addition to the power, the USB port serves as an interface to WDC’s tool suite for debugging and loading programs into the onboard SRAM.



3 Notices and Ordering Information

3.1 FCC Compliance

The Western Design Center, Inc. (WDC) provides the enclosed product under the following conditions: This board is intended for use for Engineering Development or Evaluation Purposes ONLY and is not considered by WDC to be a finished consumer product. This board should be handled with caution using good electronics handling practices. This board is compliant per RoHS/Green directives. It does not fall within the scope of directives such as FCC, CE, and UL. It generates uses and can radiate radio frequency energy and has not been tested for compliance with the limits of computing devices pursuant to part 15 of FCC rules.

3.2 Ordering Information

The W65C02SXB will be available through various distributors. For information about WDC's distribution channels, please visit: <http://65xx.com/distributors/>

X-ON Electronics

Largest Supplier of Electrical and Electronic Components

Click to view similar products for [Development Boards & Kits - Other Processors](#) category:

Click to view products by [Western Design Center \(WDC\)](#) manufacturer:

Other Similar products are found below :

[EVB-MEC1418MECC](#) [20-101-1252](#) [C29XPCIE-RDB](#) [CC-ACC-18M433](#) [MAX1464EVKIT](#) [RTE510Y470TGB00000R](#)
[RTK0EN0001D01001BZ](#) [MAXQ622-KIT#](#) [YR0K505231S000BE](#) [YR0K50571MS000BE](#) [YQB-R5F1057A-TB](#) [QB-R5F104PJ-TB](#) [CC-](#)
[ACC-ETHMX](#) [OV-7604-C7-EVALUATION-BOARD](#) [SK-AD02-D62Q1747TB](#) [SK-BS01-D62Q1577TB](#) [ST7MDT1-EMU2](#) [GROVE BASE](#)
[KIT FOR RASPBERRY PI](#) [RTK5572TKCS00000BE](#) [CAB M-M\(40-17-RAINBOW\)](#) [CY8CKIT-143A](#) [RASPBERRY PI PICO](#) [EK-](#)
[MPC5744P](#) [KITAURIXTC234TFTTOBO1](#) [ENW89854AXKF](#) [ENWF9201AVEF](#) [QB-R5F104LE-TB](#) [LV18F V6 64-80-PIN TQFP MCU](#)
[CARD EMPTY](#) [LV-24-33 V6 44-PIN TQFP MCU CARD EMPTY](#) [LV-24-33 V6 64-PIN TQFP MCU CARD EMPTY](#) [LV-24-33 V6 80-PIN](#)
[TQFP 1 MCU CARD EMPTY](#) [32X32 RGB LED MATRIX PANEL - 6MM PITCH](#) [3.3 - 5 VTRANSLATOR](#) [READY FOR XMEGA](#)
[CASING \(WHITE\)](#) [RELAY4 BOARD](#) [ETHERNET CONNECTOR](#) [RFID CARD 125KHZ - TAG](#) [RFID READER](#) [RFM12B-DEMO](#)
[MAROON](#) [3G CLICK \(FOR EUROPE AND AUSTRALIA\)](#) [MAX232](#) [MAX3232 BOARD](#) [ARTY S7-50](#) [THREE-AXIS](#)
[ACCELEROMETER BOARD](#) [TINKERKIT HALL SENSOR](#) [TOUCHPANEL](#) [TOUCHPANEL CONTROLLER](#) [MIKROBOARD FOR AVR](#)
[WITH ATMEGA128](#) [MIKROBOARD FOR PSOC WITH CY8C27643](#)