

RELAYS AND CONTACTORS

D.C. Power Contactors – Type 70

Type 70
SPNO

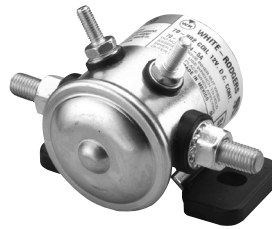

Sec.	STANCOR PART NUMBER	Duty Cycle	Terminal Type*	Pole Form	Bracket Style	Coil Volt. D.C.	Coil Resistance (Ohms) @ 25°C	Contact Material	Contact Rating-(Amps.) Inductive Load				DIMENSIONS INCHES			Weight (oz.)	Agency* Certif.	
									Volt. D.C.	Normally Open Continuous	Normally Open Inrush**	Normally Closed Continuous	Normally Closed Inrush	L	W			H
A	70-901	Continuous	4	SPNO	Standard	6	4	Copper	6	80	300	-	-	2.47	3.48	2.40	12.5	RU
	70-914	Continuous	3A	SPNO	Standard	12	16	Copper	12	80	150	-	-	2.47	3.48	2.40	12.5	RU
B	70-918	Continuous	3B	SPNO	Standard	12	16	Copper	12	80	150	-	-	2.47	3.48	2.40	12.5	RU
	70-902	Continuous	4	SPNO	Standard	12	16	Copper	12	80	150	-	-	2.47	3.48	2.40	12.5	RU
	70-906	Continuous	4	SPNO	Standard	12	16	Silver	12	80	150	-	-	2.47	3.48	2.40	12.5	RU
	70-915	Continuous	3A	SPNO	Standard	24	60	Copper	24	50	50	-	-	2.47	3.48	2.40	12.5	RU
C	70-903	Continuous	4	SPNO	Standard	24	60	Copper	24	50	50	-	-	2.47	3.48	2.40	12.5	RU
	70-907	Continuous	4	SPNO	Standard	24	60	Silver	24	50	50	-	-	2.47	3.48	2.40	12.5	RU
	70-904	Continuous	4	SPNO	Standard	36	114	Copper	36	50	50	-	-	2.47	3.48	2.40	12.5	RU
	70-908	Continuous	4	SPNO	Standard	36	114	Silver	36	50	50	-	-	2.47	3.48	2.40	12.5	RU

* Terminal Type: "3A" = Grounding coil wire supplied
 "3B" = Coil Common to Load
 "4" = Isolated Coil

For outline drawings refer to pages 50-51.

** Inrush Current: Current applied within the first 1/2 second of contact closure

* Agency Certification Note: U.L. 583 Recognized (File AU2138)

Engineering Design Data

D.C. Type	Coil Rating Nominal Magnetic Coil Rating (Watts)	Operation in % of Nom. Coil Voltage Rating		Breakdown Voltages All Terminals - 60 Hz RMS			Contact Material Power	Electrical Life		Mechanical Life		Max. Oper. Temp. °F
		Pick-up	Max. Safe Operate	Opposite Polarity	Open Contacts Same Polarity	To Ground		Oper. At Rated Load	Oper. Per Min.	Oper. At No Load	Oper. Per Min.	
70	9	75%	110%	500	500	500	Copper Silver Alloy	100,000 200,000	4 4	250,000 250,000	4 4	122 -

Temperature Range

— -40°F to 122°F

Terminations

— Contacts: 5/16"-24 UNF-2A thread
 — Coil: #10-32 UNF-2A thread

Recommended Mounting

— Plunger vertical with cap down

Hardware Torque Specification

— Contact Terminal: 45-55 inch-lbs.
 — Coil Terminal: 12-18 inch-lbs.
 — Insulated Mounting Brackets
 — **Caution: A back-up wrench must be used to hold the bottom nut stationary.**

Type 70 Custom Design Capabilities

— Coil Voltage 6 VDC through 36 VDC
 — Curved mounting bracket
 — Please complete application data form on page 95 of this section.

Note: Caution must be used in coil selection for use in 12 volt systems where battery charging may expose coil to continuous, higher-than-rated voltage.
Stancor will not be responsible for consequences of misapplied solenoids.

RELAYS AND CONTACTORS

D.C. Power Contactors – Type 70

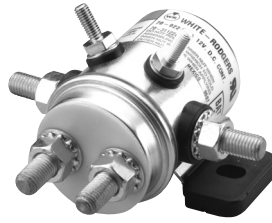

Type 70
SPDT



Sec.	STANCOR PART NUMBER	Duty Cycle	Terminal Type*	Pole Form	Bracket Style	Coil Volt. D.C.	Coil Resistance (Ohms) @ 25°C	Contact Material	Contact Rating-(Amps.) Inductive Load				DIMENSIONS INCHES			Weight (oz.)	Agency* Certif.	
									Volt. D.C.	Normally Open Continuous	Normally Open Inrush**	Normally Closed Continuous	Normally Closed Inrush**	L	W			H
A	70-922	Continuous	6	SPDT	Standard	12	16	N.O. Copper N.C. Silver	12	80	300	60	60	3.31	3.48	2.40	14.0	
	70-910	Continuous	6	SPDT	Standard	12	16	N.O. and N.C. Silver	12	80	150	60	60	3.31	3.48	2.40	14.0	
B	70-923	Continuous	6	SPDT	Standard	24	60	N.O. Copper N.C. Silver	24	50	50	30	30	3.31	3.48	2.40	14.0	
	70-911	Continuous	6	SPDT	Standard	24	60	N.O. and N.C. Silver	24	50	50	30	30	3.31	3.48	2.40	14.0	
	70-912	Continuous	6	SPDT	Standard	36	114	N.O. and N.C. Silver	36	50	50	30	30	3.31	3.48	2.40	14.0	

* Terminal Type: "6" = Isolated Coil

** Inrush Current: Current applied within the first 1/2 second of contact closure

★ Based on 50K Cycles

* Agency Certification Note: U.L. 583 Recognized (File AU2138)

For outline drawings refer to page 51.

Engineering Design Data

D.C. Type	Coil Rating Nominal Magnetic Coil Rating (Watts)	Operation in % of Nom. Coil Voltage Rating		Breakdown Voltages All Terminals - 60 Hz RMS			Contact Material		Electrical Life		Mechanical Life		Max. Oper. Temp. °F
		Pick-up	Max. Safe Operate	Opposite Polarity	Open Contacts Same Polarity	To Ground	Power	Pilot	Oper. At Rated Load	Oper. Per Min.	Oper. At No Load	Oper. Per Min.	
70	9	75%	110%	500	500	500	Copper	-	100,000	4	250,000	4	122
							Silver	-	200,000	4	250,000	4	-

Temperature Range

— -40°F to 122°F

Terminations

- Contacts: 5/16"-24 UNF-2A thread
- Coil: #10-32 UNF-2A thread

Recommended Mounting

— Plunger vertical with cap down

Hardware Torque Specification

- Contact Terminal: 45-55 inch-lbs.
- Coil Terminal: 12-18 inch-lbs.
- **Caution: A back-up wrench must be used to hold the bottom nut stationary.**

Type 70 Custom Design Capabilities

- Coil Voltage 6 VDC through 36 VDC
- Curved mounting bracket
- Please complete application data form on page 95 of this section.

Note: Caution must be used in coil selection for use in 12 volt systems where battery charging may expose coil to continuous, higher-than-rated voltage.
Stancor will not be responsible for consequences of misapplied solenoids.

RELAYS AND CONTACTORS

Type 70

Terminal Type 4 – Isolated Coil

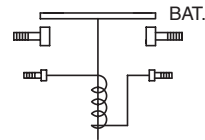
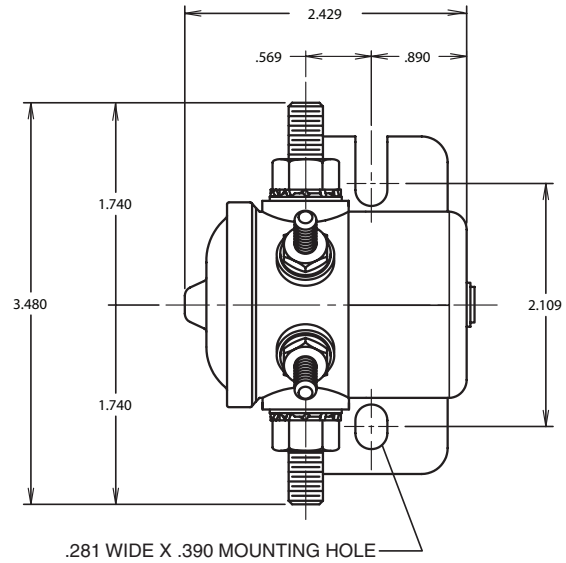
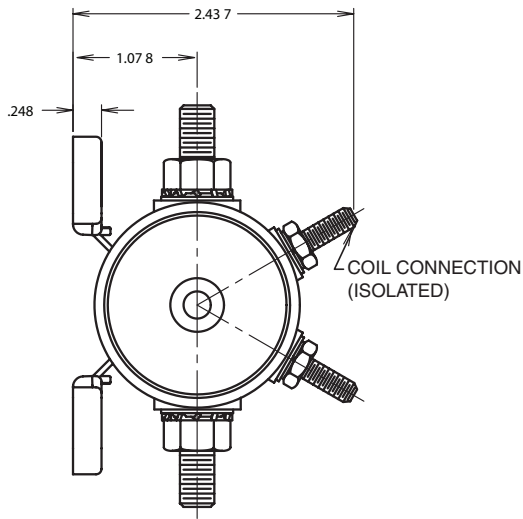

CIRCUIT DIAGRAM

Terminal Type 3A – Coil Terminal to Ground

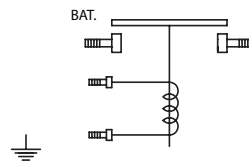
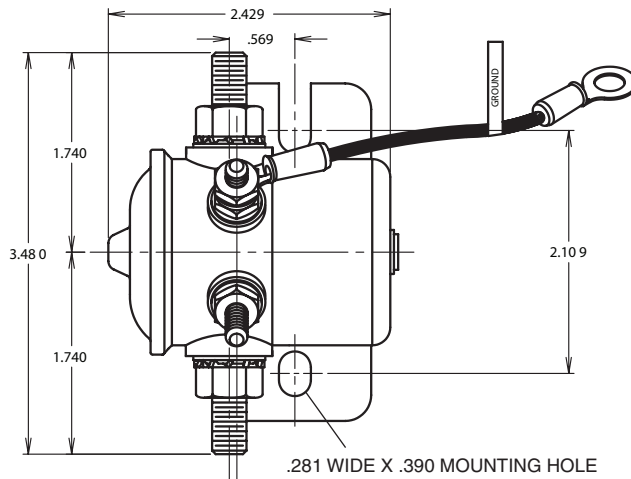
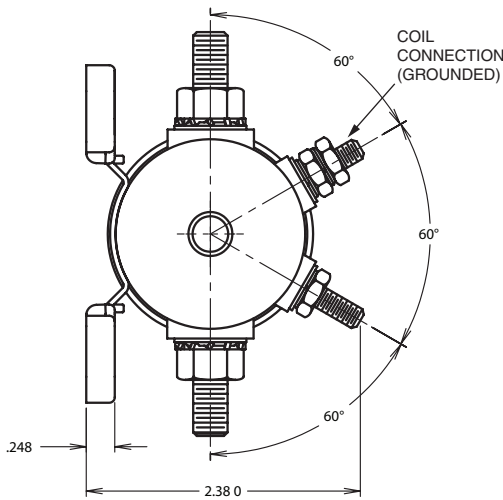

CIRCUIT DIAGRAM

Terminal Type 3B – Coil Common to Load

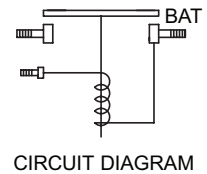
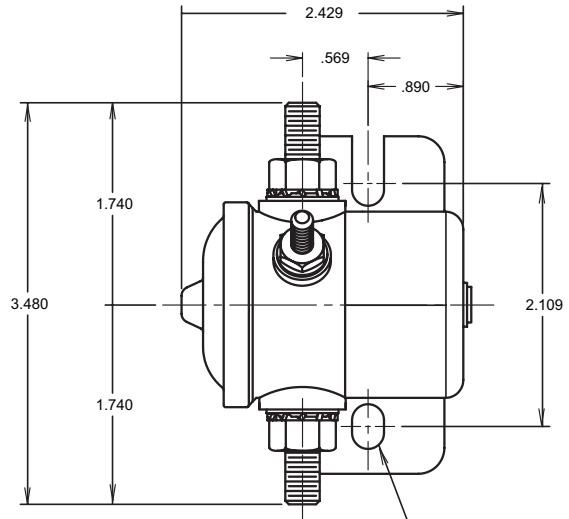
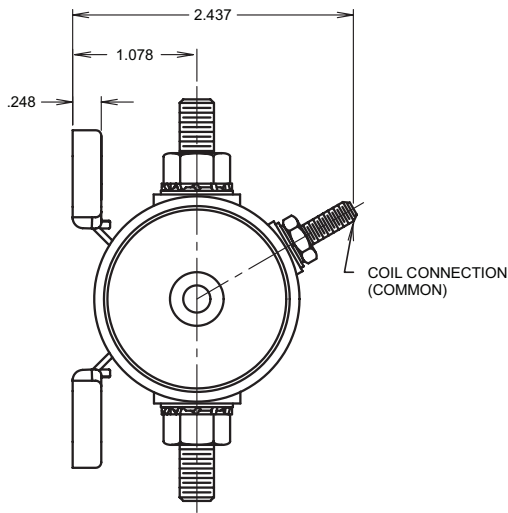

Terminal Type 6 – Isolated Coil

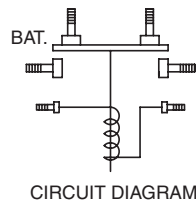
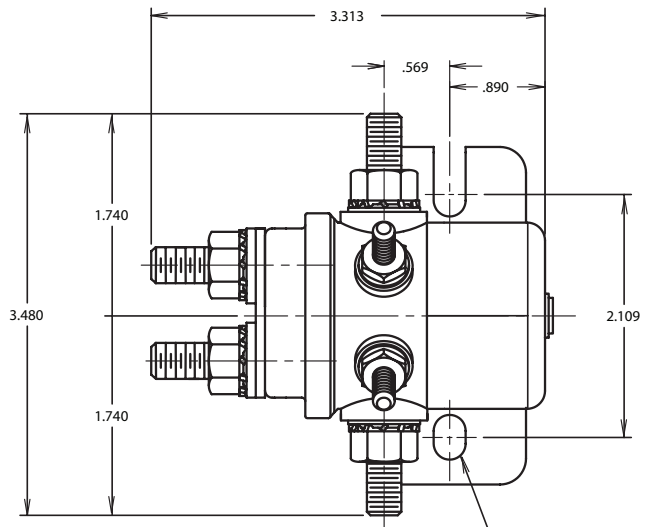
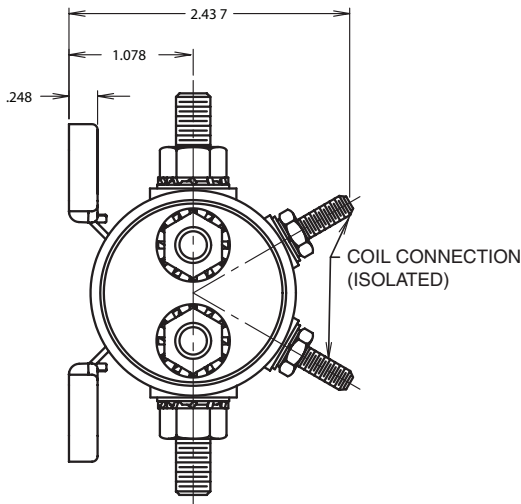

X-ON Electronics

Largest Supplier of Electrical and Electronic Components

Click to view similar products for [Industrial Relays](#) category:

Click to view products by [White-Rodgers](#) manufacturer:

Other Similar products are found below :

[6-1618400-7](#) [686-117111](#) [686-120111](#) [EV250-4A-02](#) [EV250-6A-01](#) [FCA-125-CX8](#) [FCA-410-138](#) [8-1618393-1](#) [GCA32A208VAC60HZ](#)
[GCA32A220VAC50/60HZ](#) [GCA32A230VAC50/60HZ](#) [GCA32A240VAC50/60HZ](#) [GCA32A48VAC60HZ](#) [GCA63A120VAC50/60HZ](#)
[GCA63A208VAC60HZ](#) [GCA63A220VAC60HZ](#) [GCA63A230VAC50/60HZ](#) [GCA63A240VAC50/60HZ](#) [GCA63A277VAC60HZ](#)
[GCA63A48VAC60HZ](#) [GCA63A500VAC50/60HZ](#) [GCA63A600VAC60HZ](#) [GCA800A200VACDC](#) [GCA95A110VAC50/60HZ](#)
[GCA95A120VAC50/60HZ](#) [GCA95A12VDC](#) [GCA95A240VAC50/60HZ](#) [GCA95A24VAC50/60HZ](#) [GCA95A48VAC60HZ](#) [ACC530U20](#)
[ACC730U30](#) [1395832-1](#) [RM699BV-3011-85-1005](#) [RMIA210230AC](#) [RMIA45024AC](#) [1423675-8](#) [B07B032AC1-0329](#) [B329](#) [1617807-1](#)
[N417](#) [P25-E5019-1](#) [P30C42A12D1-120](#) [2-1618398-1](#) [PBO-18A1218](#) [2307497](#) [RPYA00324LT](#) [RPYA003A120LT](#) [KR-4539-1](#)
[RT334012WG](#) [S160156115](#)