

Expansion thermometer Model 70, stainless steel version

WIKA data sheet TM 81.01



for further approvals
see page 8

Applications

- General-purpose temperature measuring instruments for gaseous, liquid and highly-viscous process media in harsh working environments
- Refrigeration industry
- Machine building

Special features

- Case and stem made of stainless steel
- Design per EN 13190
- Different designs of connection and mounting
- With capillary
- With various fixed connections



Fig. left: expansion thermometer model M70.50.100
Fig. right: expansion thermometer model B70.50.063

Description

This series of thermometers is universally suitable for machine building, refrigeration and air-conditioning industry. Expansion thermometers can be installed in or mounted at nearly all locations. Versions with capillaries are used in locations which are not easily accessible and where long distances have to be bridged.

Case, capillary, stem and process connection are made from stainless steel. Various insertion lengths and process connections are available to match the requirements of each measuring location optimally.

Standard version

Measuring principle

Bourdon tube system

Nominal size in mm

63, 100, 160

Design of connection

- 1 Plain stem (without thread)
- 2 Male nut
- 3 Union nut
- 4 Compression fitting (sliding on stem)
- 5 Union nut with fitting
- 6 Compression fitting (sliding on capillary)

Instrument version and type of mounting

- B Instruments with capillary; centre back mount triangular bezel with bracket
- H Instruments with capillary; lower mount (radial) surface mounting flange
- M Instruments with capillary; lower mount (radial) surface mounting bracket, aluminium die cast
- V Instruments with capillary; back mount ¹⁾ panel mounting flange
- A Back mount ¹⁾, fix plain stem, threaded connection or thermowell
- R Lower mount (radial), fix plain stem, threaded connection or thermowell
- S Back mount ¹⁾, fix plain stem, threaded connection or thermowell; swivelling approx. 90 °

1) eccentric; NS 63: centric

Fill medium measuring system

Xylol or silicon oil

Accuracy class

Class 2

Rated operating ranges and conditions

EN 13190

Capillary entry

Lower or back

Case

Stainless steel

Bezel ring

Stainless steel

Connection

Stainless steel 1.4571

Capillary

Length to customer specifications (max. 10 m), Ø 2 mm, stainless steel 1.4571, bending radius not less than 6 mm

Stem

Ø 8 mm, stainless steel 1.4571

Active length of sensor

Depending on Ø d and scale range

Dial

Aluminium, white, black lettering

Pointer

Aluminium, black

Window

NS 100, 160: Instrument glass

NS 63: Transparent plastic

Temperature limits for storage and transport

-50 ... +70 °C (EN 13190) without liquid damping

-20 ... +60 °C (EN 13190) with food-compatible liquid damping

-50 ... +60 °C (EN 13190) with liquid damping

Ambient temperature limit at the case

0 ... 40 °C max. (others on request)

Pressure rating of stem

25 bar max., static

Ingress protection

IP 65 per EN 60529 / IEC 529

Options

- Scale range °F, °C/°F (dual scale)
- Laminated safety glass, clear plastic
- Ambient temperature compensation
- Accuracy class 1.0
- Thermowell per DIN or to customer specification
- Surface mounting bracket from other materials and in other lengths (A)
- Liquid filling case with
 - NS 63: Model X70.53.063
 - NS 100: Model X70.53.100
 - NS 160: Model X70.53.160
 - Filling medium: glycerine
- Spiral protecting hose stainless steel
- Designs per DIN EN ISO 13485, medical applications on request
- Model 70 with micro switch see WIKA data sheet TV 28.01
- Stem diameter 6, 10 mm

Scale ranges, measuring ranges 1)

Scale range in °C	Measuring range in °C	Limit error ±°C	Scale division in °C
-60 ... +40	-50 ... +30	2	1
-40 ... +60	-30 ... +50	2	1
-30 ... +50	-20 ... +40	2	1
-20 ... +60	-10 ... +50	2	1
-20 ... +80	-10 ... +70	2	1
0 ... 60	10 ... 50	2	1
0 ... 80	10 ... 70	2	1
0 ... 100	10 ... 90	2	1
0 ... 120	10 ... 110	4	2
0 ... 160	20 ... 140	4	2
0 ... 200	20 ... 180	4	2
0 ... 250	30 ... 220	5	5
0 ... 300	30 ... 270	10	10
0 ... 400	50 ... 350	10	10

Other scale ranges on request.

1) The measuring range is indicated on the dial by two triangular marks.
The stated limit of error per EN 13190 is only valid within this range.

Models

Model	NS	Connection location	Type of mounting
B70.50 (instruments without liquid filling) B70.53 (instruments with liquid filling)	063	Centre back mount	Triangular bezel with bracket
H70.50 (instruments without liquid filling) H70.53 (instruments with liquid filling)	063 100 160	Lower mount (radial)	Surface mounting flange
M70.50 (instruments without liquid filling) M70.53 (instruments with liquid filling)	063 100 160	Lower mount (radial)	Surface mounting bracket
V70.50 (instruments without liquid filling) V70.53 (instruments with liquid filling)	063 100 160	Centre back mount Lower back mount	Panel mounting flange
A70.50 (instruments without liquid filling) A70.53 (instruments with liquid filling)	063 100	Centre back mount, fix Lower back mount, fix	via connection (plain stem), threaded connection or thermowell
R70.50 (instruments without liquid filling) R70.53 (instruments with liquid filling)	063 100	Lower mount (radial), fix	via connection (plain stem), threaded connection or thermowell
S70.50 (instruments without liquid filling) S70.53 (instruments with liquid filling)	063 100	Centre back mount, fix Lower back mount, fix	via connection (plain stem), threaded connection or thermowell; swivelling approx. 90° ↺

Connection designs

Design 1, plain connection (without thread)

Insertion length $l = 140, 200, 240, 290$ mm
 Basis for design 4, compression fitting

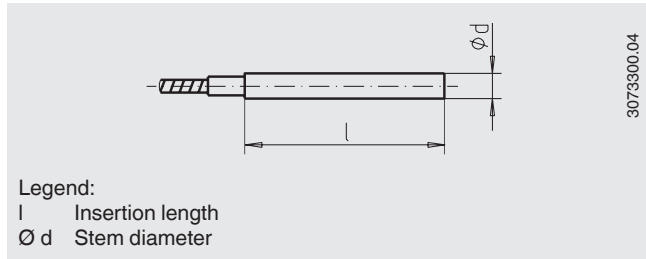

Legend:
 l Insertion length
 $\varnothing d$ Stem diameter

3073300.04

Design 2, male nut

Process connection: $G \frac{1}{2} B$
 Insertion length $l_1 = 80, 140, 180, 230$ mm

Process connection G	Dimensions in mm	
	SW	i
$G \frac{1}{2} B$	27	20

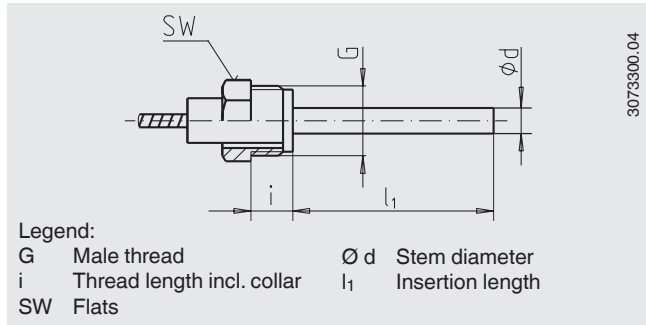

Legend:
 G Male thread $\varnothing d$ Stem diameter
 i Thread length incl. collar l_1 Insertion length
 SW Flats

3073300.04

Design 3, union nut

Process connection: $G \frac{1}{2}, G \frac{3}{4}, M24 \times 1.5$
 Insertion length $l_1 = 89, 126, 186, 226, 276$ mm

Process connection G	Dimensions in mm	
	SW	i
$G \frac{1}{2}$	27	8.5
$G \frac{3}{4}$	32	10.5
$M24 \times 1.5$	32	13.5

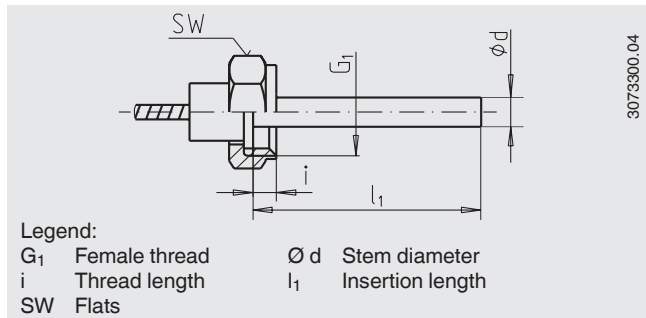

Legend:
 G_1 Female thread $\varnothing d$ Stem diameter
 i Thread length l_1 Insertion length
 SW Flats

3073300.04

Design 4, compression fitting (sliding on stem)

Process connection: $G \frac{1}{2} B, G \frac{3}{4} B, M18 \times 1.5, \frac{1}{2} NPT, \frac{3}{4} NPT$
 Insertion length $l_1 = 100, 160, 200, 250$ mm
 (the insertion length used can be reduced to a minimum immersion length of $l_{min} = 60$ mm)

Process connection G	Dimensions in mm		
	SW	d_4	i
$G \frac{1}{2} B$	27	26	14
$G \frac{3}{4} B$	32	32	16
$M18 \times 1.5$	24	23	12
$\frac{1}{2} NPT$	22	-	19
$\frac{3}{4} NPT$	30	-	20

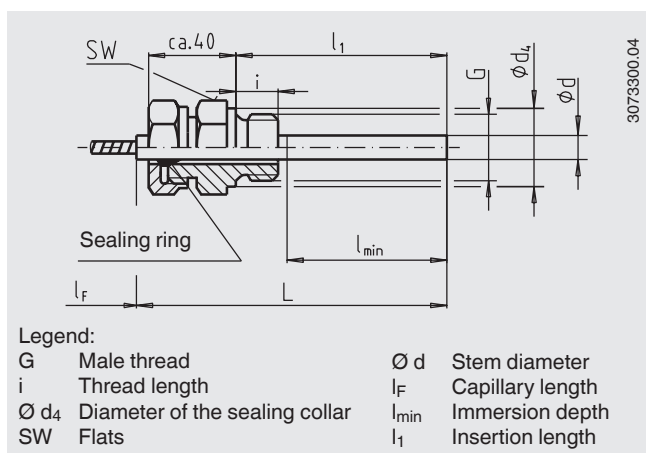

Legend:
 G Male thread $\varnothing d$ Stem diameter
 i Thread length l_F Capillary length
 $\varnothing d_4$ Diameter of the sealing collar l_{min} Immersion depth
 SW Flats l_1 Insertion length

3073300.04

Design 5, union nut with fitting

Union nut: G 1/2
 Process connection: G 1/2 B, G 3/4 B or 1/2 NPT, 3/4 NPT

Option:
 Union nut: M24 x 1.5
 Process connection: M18 x 1.5
 Insertion length $l_1 = 63, 100, 160, 200, 250$ mm

Process connection	Dimensions in mm		
	G	SW	d_4
G 1/2 B	27	26	14
G 3/4 B	32	32	16
M18 x 1.5	24	23	12
1/2 NPT	22	-	19
3/4 NPT	30	-	20

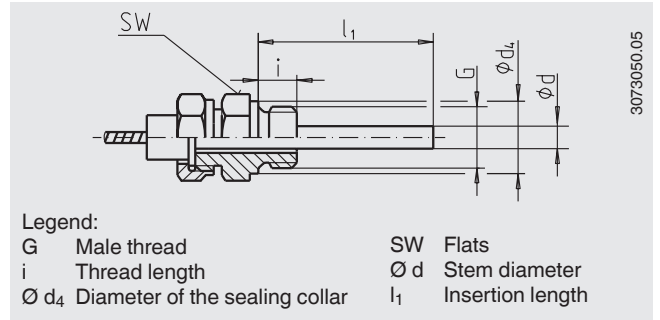

Legend:
 G Male thread
 i Thread length
 ϕd_4 Diameter of the sealing collar
 SW Flats
 ϕd Stem diameter
 l_1 Insertion length

Design 6, compression fitting (sliding on capillary)

Process connection: G 1/2 B, G 3/4 B or 1/2 NPT, 3/4 NPT
 Insertion length $l = 100, 140, 200, 240, 290$ mm

Process connection	Dimensions in mm		
	G	SW	d_4
G 1/2 B	27	26	14
G 3/4 B	32	32	16
1/2 NPT	22	-	19
3/4 NPT	30	-	20

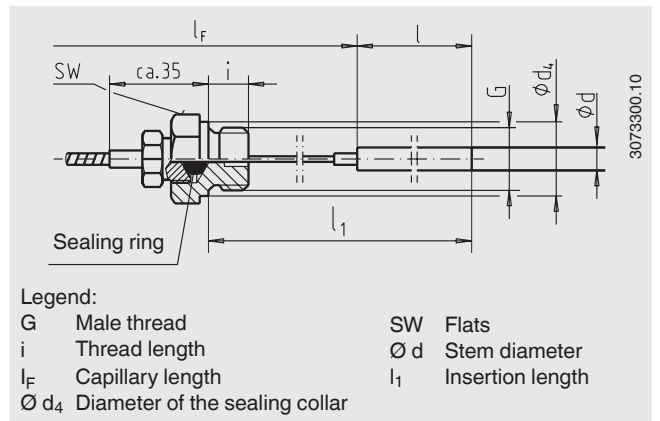

Legend:
 G Male thread
 i Thread length
 l_F Capillary length
 ϕd_4 Diameter of the sealing collar
 SW Flats
 ϕd Stem diameter
 l_1 Insertion length

Dimensions in mm

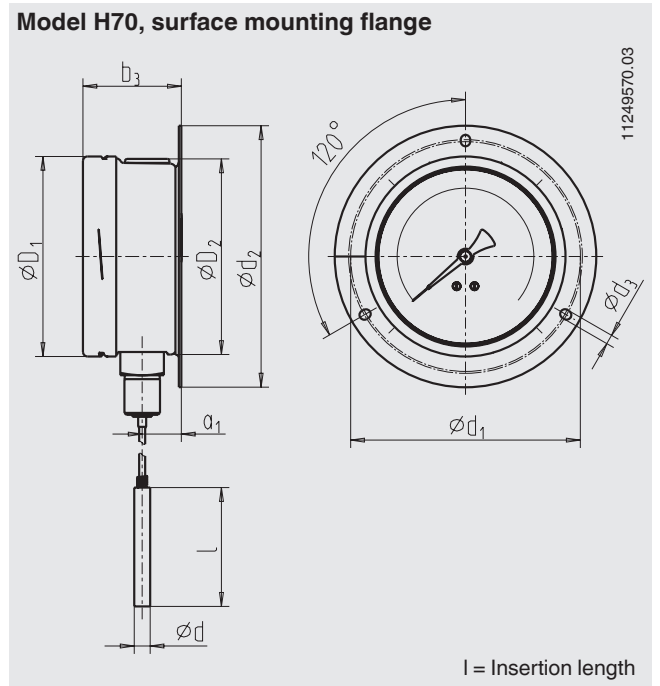
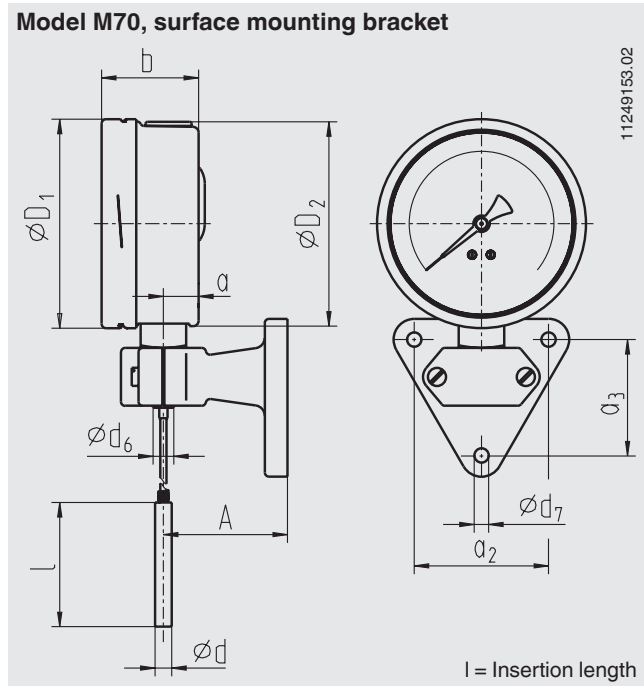

NS	Dimensions in mm															Weight in kg	
	a	a ₁	a ₂	a ₃	b	b ₁	b ₃	ϕd	ϕd_1	ϕd_2	ϕd_3	ϕd_6	ϕd_7	A	ϕD_1		ϕD_2
63	10.5	13	65	56	32.5	32.5	34.5	8	75	85	3.6	14	7	60	63.5	62	0.4
100	15.5	22	65	56	49.5	49.5	50.0	8	116	132	4.8	18	7	60	101.0	99	0.9
160	15.5	22	65	56	49.5	-	50.0	8	178	196	6.0	18	7	60	161.0	159	1.40

Model V70, panel mounting flange

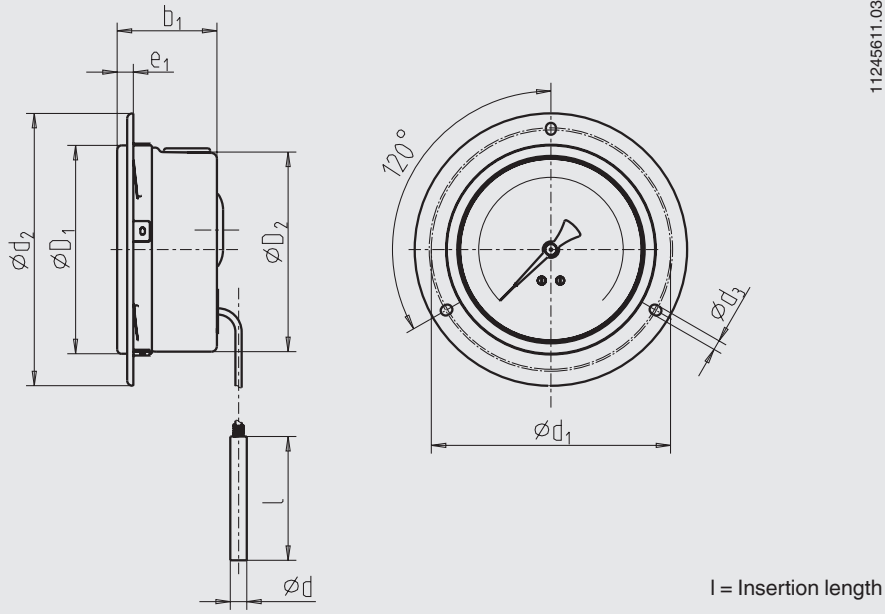

NS	Dimensions in mm								Weight in kg
	b ₁	Ø d	Ø d ₁	Ø d ₂	Ø d ₃	e ₁	Ø D ₁	Ø D ₂	
63	32.5	8	75	85	3.6	5	63.5	62	0.4
100	49.5	8	116	132	4.8	8	101.0	99	0.9
160	-	8	178	196	6.0	8	161.0	159	1.40

Model B70, triangular bezel with bracket

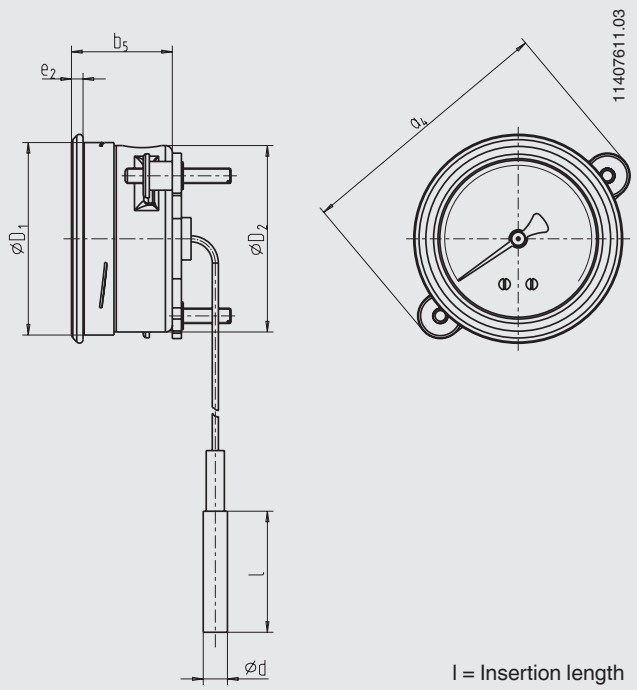

NS	Dimensions in mm						Weight in kg
	a ₄	b ₅	Ø d	e ₂	Ø D ₁	Ø D ₂	
63	87	33.5	8	4	63.5	62	0.4

Model R70, lower mount

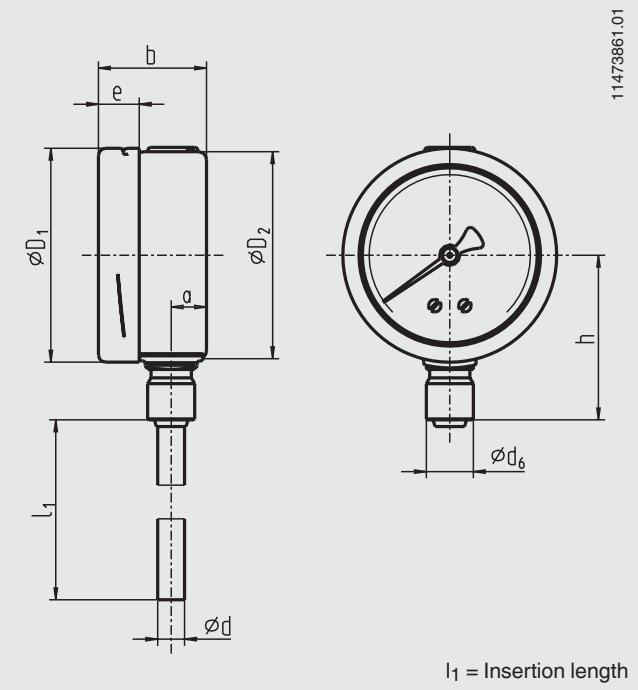

NS	Dimensions in mm								Weight in kg
	a	b	Ø d	Ø d ₆	e	h	Ø D ₁	Ø D ₂	
63	10.5	32.5	8	14	12.2	49.0	63.5	62	0.4
100	15.5	49.5	8	18	16.8	68.5	101.0	99	0.9

Model S70, case swivelling approx. 90 °

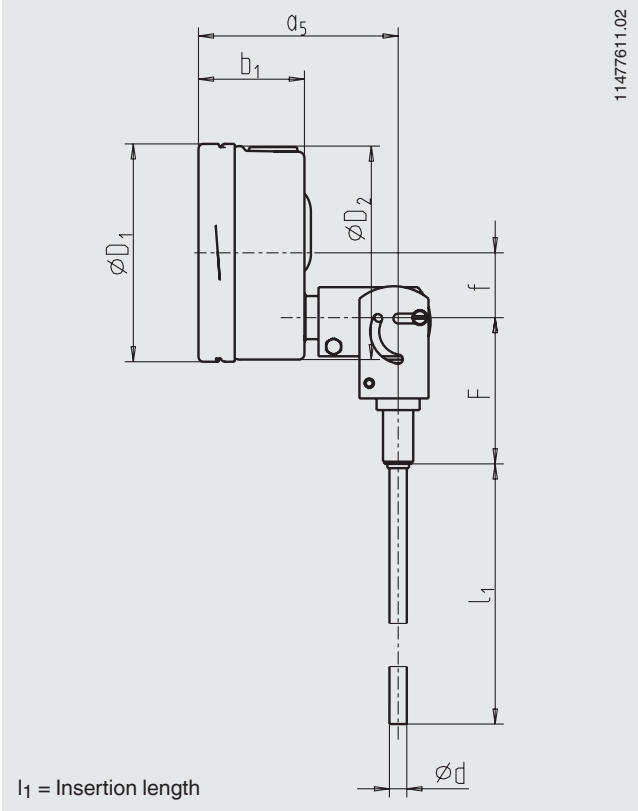

NS	Dimensions in mm							Weight in kg
	a_5	b_1	$\varnothing d$	f	$\varnothing D_1$	$\varnothing D_2$	F	
63	83	32.5	8	0	63.5	62	68	0.4
100	93	49.5	8	30	101.0	99	68	0.9

Model A70, back mount (NS 63)

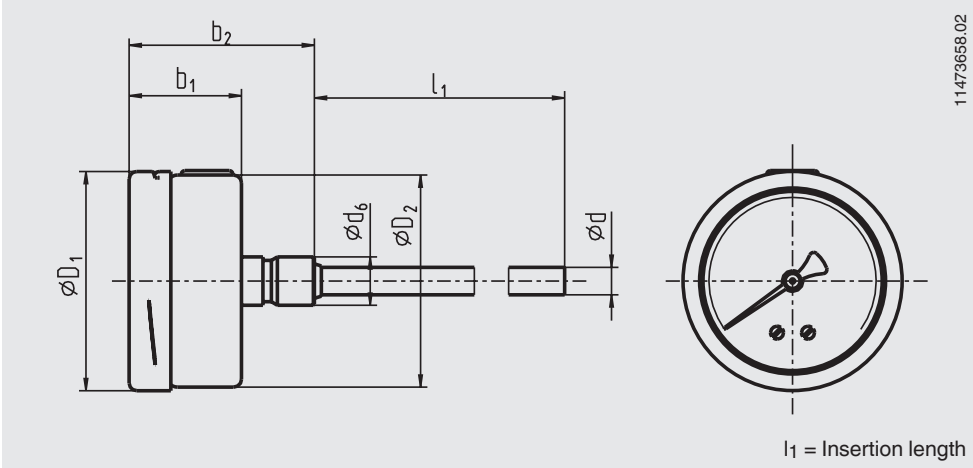

NS	Dimensions in mm						Weight in kg
	b_1	b_2	$\varnothing d$	$\varnothing d_6$	$\varnothing D_1$	$\varnothing D_2$	
63	32.5	54.0	8	14	63.5	62	0.4

Model A70, back mount (NS 100)

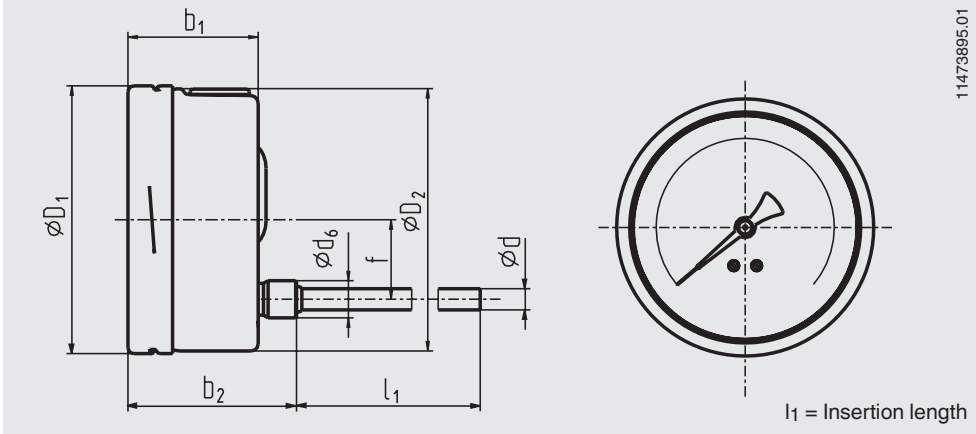

NS	Dimensions in mm							Weight in kg
	b_1	b_2	$\varnothing d$	$\varnothing d_6$	f	$\varnothing D_1$	$\varnothing D_2$	
100	49.5	63.5	8	18	30	101.0	99	0.9

Approvals

- GOST-R, import certificate, Russia
- GOST, metrology/measurement technology, Russia
- CRN, safety (e.g. electr. safety, overpressure, ...), Canada,

Approvals and certificates, see website

Ordering information

Model / Nominal size / Type of mounting / Design of connection / Scale range / Process connection / Stem diameter / Insertion length / Capillary design and length / Options

© 2009 WIKA Alexander Wiegand SE & Co. KG, all rights reserved.
The specifications given in this document represent the state of engineering at the time of publishing.
We reserve the right to make modifications to the specifications and materials.



WIKAI Alexander Wiegand SE & Co. KG
Alexander-Wiegand-Straße 30
63911 Klingenberg/Germany
Tel. +49 9372 132-0
Fax +49 9372 132-406
info@wika.de
www.wika.de

X-ON Electronics

Largest Supplier of Electrical and Electronic Components

Click to view similar products for [Environmental Test Equipment](#) category:

Click to view products by [Wika](#) manufacturer:

Other Similar products are found below :

[CW40](#) [F150C10E3DRT](#) [F150LTC20](#) [F150CD10E2](#) [F150L75](#) [F150LRS](#) [2837806](#) [4328074](#) [4366444](#) [S-11](#) [382153](#) [700PTP-1](#) [GEO-](#)
[CABLE-REEL-50M](#) [H115](#) [H300](#) [F150-SLC50](#) [AW-CO-1000](#) [AW-H2S-100](#) [AW-NmHc-100](#) [ES1-CO-1000-01](#) [ES4-CO-1000-01](#) [TM-414](#)
[HS115](#) [SHG-02](#) [SHS-05](#) [SHG-01](#) [RH520-220](#) [TESTO 175-H1 0572 1754](#) [TESTO 830-T1 0560 8311](#) [AX-5002](#) [AX-5003](#) [AX-B150](#) [AX-](#)
[B180](#) [AX-B350](#) [AX-L230](#) [AX-PH02](#) [12227021](#) [12228657](#) [12229067](#) [12230090](#) [7358958](#) [12226653](#) [12230146](#) [12230171](#) [12229190](#)
[12228801](#) [12228665](#) [12228819](#) [12229360](#) [12230502](#)