

1-Line Bidirectional ESD Protection Diode

General description

Low capacitance bidirectional ElectroStatic Discharge (ESD) protection diode in a DFN1006(SOD882) leadless ultra small Surface-Mounted Device (SMD) plastic package designed to protect one signal line from the damage caused by ESD and other transients.

Features and benefits

- . Femtofarad capacitance: $C_j = 8\text{pF}$ (Typ)
- . Ultra Low Leakage: nA Level
- . Low clamping voltage $V_C = 21\text{ V}$
- . IEC 61000-4-2:
Air discharge: $\pm 15\text{KV}$, Contact discharge: $\pm 30\text{KV}$
- . IEC 61000-4-5 (8/20 μs): $I_{PPM} = 8.0\text{ A}$
- . RoHS Compliant

Application information

- . Cellular Handsets and Accessories
- . Keypads, Side Keys, LCD Displays
- . Notebooks and Handhelds
- . Personal Digital Assistants
- . Portable Instrumentation
- . Digital Cameras
- . Audio Players
- . Peripherals

Ordering information

| Device | Package | Marking | Packaging |
|----------|------------|---------|-------------------|
| ESD8D12C | DFN1006-2L | AA | 10000/Tape & Reel |

Schematic & Pin configuration

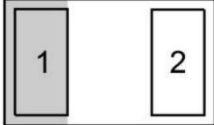
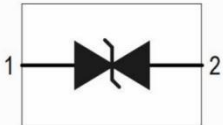
| Simplified outline | Graphic symbol |
|---|--|
|  |  |

Maximum Ratings ($T_{OP} = 25 \text{ } ^\circ\text{C}$, unless otherwise specified)

| Parameter | Symbol | Value | Unit |
|--|-----------|-------------|------------------|
| Peak Pulse Power ($T_p = 8/20 \text{ } \mu\text{s}$) | P_{PPM} | 136 | W |
| Rated Peak Pulse Current ($T_p = 8/20 \text{ } \mu\text{s}$) | I_{PPM} | 8.0 | A |
| Maximum lead temperature for soldering during 10s | T_L | 260 | $^\circ\text{C}$ |
| Storage Temperature Range | T_{stg} | -55 to +150 | $^\circ\text{C}$ |
| Operating Temperature Range | T_{OP} | -40 to +125 | $^\circ\text{C}$ |
| Maximum junction temperature | T_j | 150 | $^\circ\text{C}$ |
| ESD voltage IEC 61000-4-2 (air discharge) | V_{ESD} | 30 | kV |
| ESD voltage IEC 61000-4-2 (contact discharge) | V_{ESD} | 30 | kV |

Electrical Characteristics ($T_{OP} = 25 \text{ } ^\circ\text{C}$, unless otherwise specified)

| Parameter | Symbol | Min | Typ | Max | Unit | Condition |
|----------------------------|-----------|------|-----|------|------|---|
| Reverse Working Voltage | V_{RWM} | -- | -- | 12.0 | V | |
| Breakdown Voltage | V_{BR} | 13.0 | -- | 15.5 | V | $I_T=1\text{mA}$ |
| Leakage Current I_{Leak} | I_r | -- | -- | 200 | nA | $V_{RWM}=12\text{V}$ |
| Clamping Voltage | V_C | -- | -- | 17.0 | V | $I_{PP}=8.0\text{A}, T_p=8/20\mu\text{s}$ |
| Junction Capacitance | C_j | -- | 8 | 12 | pF | $V_R=0\text{V}, f=1\text{MHz}$ |

Typical Electrical and Thermal Characteristics (Curves)

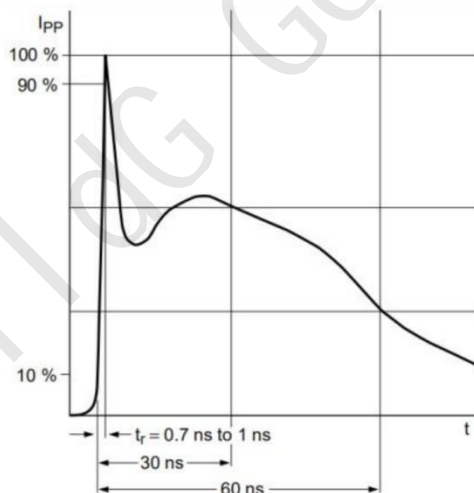

IEC61000-4-2 Waveform

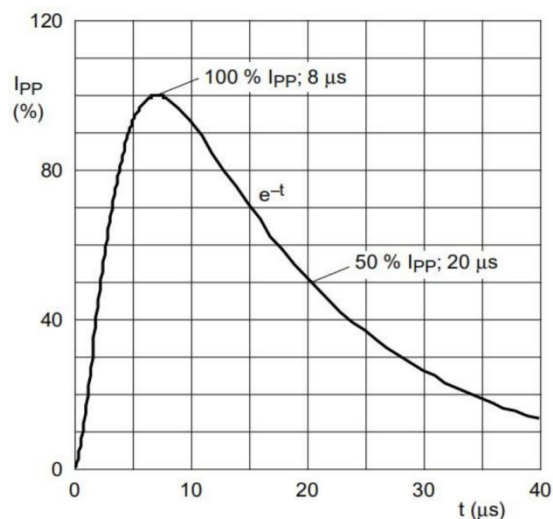

IEC 61000-4-5 Waveform (8/20 μs pulse)

Package Outline Dimensions

DFN1006-2L

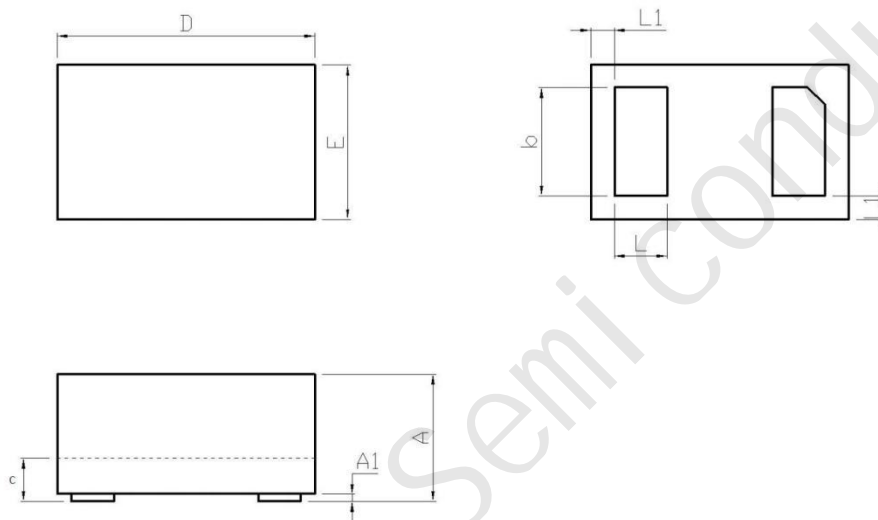

| DFN1006-2L (mm) | | | |
|-----------------|-------|------|-------|
| Dim | Min | Typ. | Max |
| A | 0.45 | 0.50 | 0.55 |
| A1 | 0 | 0.02 | 0.05 |
| b | 0.45 | 0.5 | 0.55 |
| c | 0.1 | 0.15 | 0.18 |
| D | 0.95 | 1.00 | 1.05 |
| E | 0.55 | 0.60 | 0.65 |
| L | 0.20 | 0.25 | 0.30 |
| L1 | 0.035 | 0.05 | 0.065 |

X-ON Electronics

Largest Supplier of Electrical and Electronic Components

Click to view similar products for [ESD Suppressors / TVS Diodes](#) category:

Click to view products by [Wild Goose](#) manufacturer:

Other Similar products are found below :

[60KS200C](#) [D18V0L1B2LP-7B](#) [D5V0F4U5P5-7](#) [NTE4902](#) [P4KE27CA](#) [P6KE11CA](#) [P6KE8.2A](#) [SA60CA](#) [SA64CA](#) [SMBJ12CATR](#)
[SMBJ33CATR](#) [SMBJ6.5A](#) [SMBJ8.0A](#) [ESD101-B1-02ELS E6327](#) [ESD112-B1-02EL E6327](#) [ESD7451N2T5G](#) [19180-510](#) [CPDT-5V0USP-](#)
[HF](#) [3.0SMCJ33CA-F](#) [3.0SMCJ36A-F](#) [HSPC16701B02TP](#) [JANTX1N6126A](#) [D3V3Q1B2DLP3-7](#) [D55V0M1B2WS-7](#) [SCM1293A-04SO](#)
[ESD200-B1-CSP0201 E6327](#) [SM12-7](#) [CEN955 W/DATA](#) [VESD12A1A-HD1-GS08](#) [CPDQC5V0-HF](#) [D1213A-01LP4-7B](#) [ESD101-B1-02EL](#)
[E6327](#) [AOZ8808DI-03](#) [5KP15A](#) [5KP48A](#) [5KP90A](#) [ESD3V3D7-TP](#) [15KPA36A-LF](#) [P4KE56CA](#) [P4KE68A](#) [P4KE91CATR](#) [P6KE120A](#)
[P6KE13CA](#) [P6KE43CA](#) [P6KE6.8CA](#) [P6KE8.2](#) [P6SMBJ20CA](#) [JANTX1N6072A](#) [SR2835ESKG](#) [SA90CA](#)