

MUR3020PT - MUR3060PT  
30A SUPER FAST RECOVERY



MUR3020PT - MUR3060PT

Features:

- High Surge Capability
- Low Forward Voltage Drop
- High Current Capability
- Super Fast Switching Speed For High Efficiency



TO-247

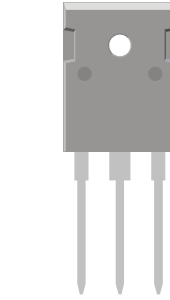

1. Anode 2. Cathode 3. Anode

**Absolute Maximum Ratings** (Ta=25°C unless otherwise noted)

Parameter	Symbol	MUR3020PT	MUR3040PT	MUR3060PT	Unit
Maximum Recurrent Peak Reverse Voltage	VRRM	200	400	600	V
Maximum RMS Voltage	VRMS	140	280	420	
Maximum DC Blocking Voltage	VR(DC)	200	400	600	
Maximum Average Forward Current	IF(AV)	30			A
Peak Forward Surge Current: 8.3ms single half sine-wave superimposed on rated load (JEDEC method)	IFSM	250			
Maximum Forward Voltage at 15A per leg	VF	0.9	1.3	1.7	V
Maximum DC Reverse Current at Rated DC Blocking Voltage	Tj=25°C	0.2			mA
	Tj=125°C	5			
Maximum Operating Junction Temperature	Tj	150			°C
Storage Temperature	Tstg	-35 ~ +150			
Typical Thermal Resistance	RθJC	1.5			°C/W

Typical Characteristics

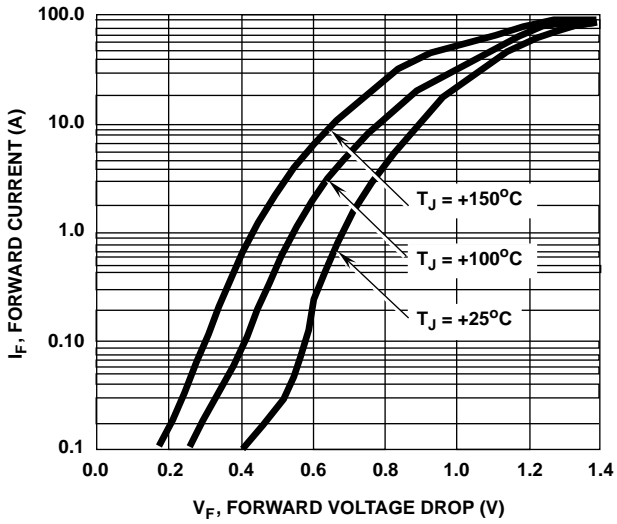

FIGURE 3. FORWARD VOLTAGE vs FORWARD CURRENT CHARACTERISTIC

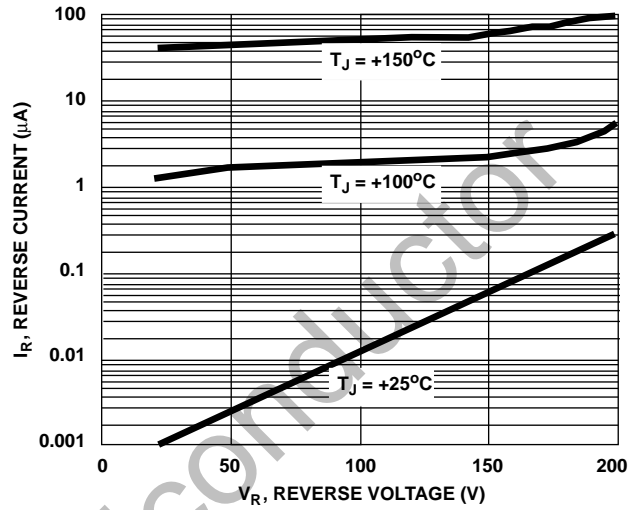

FIGURE 4. REVERSE VOLTAGE vs REVERSE CURRENT CHARACTERISTIC

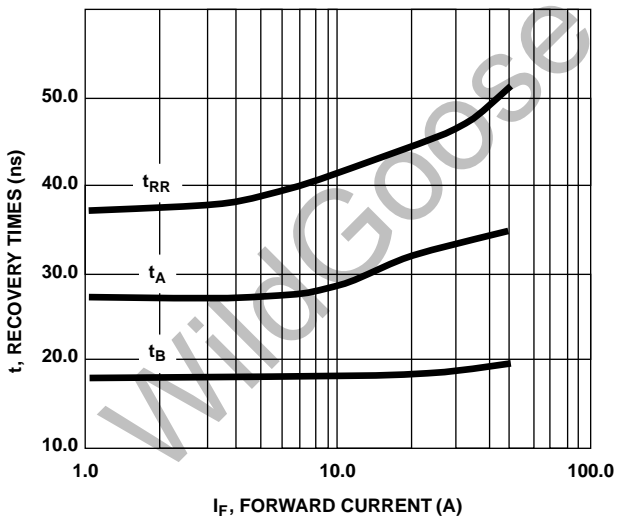

FIGURE 5. TYPICAL  $t_{RR}$ ,  $t_A$  AND  $t_B$  CURVES vs FORWARD CURRENT

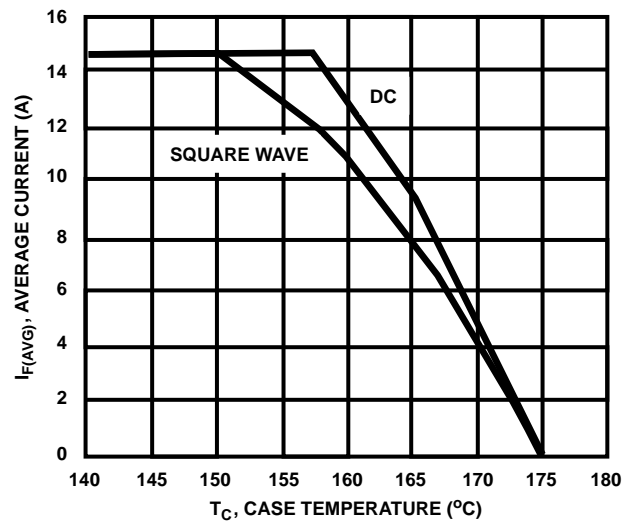
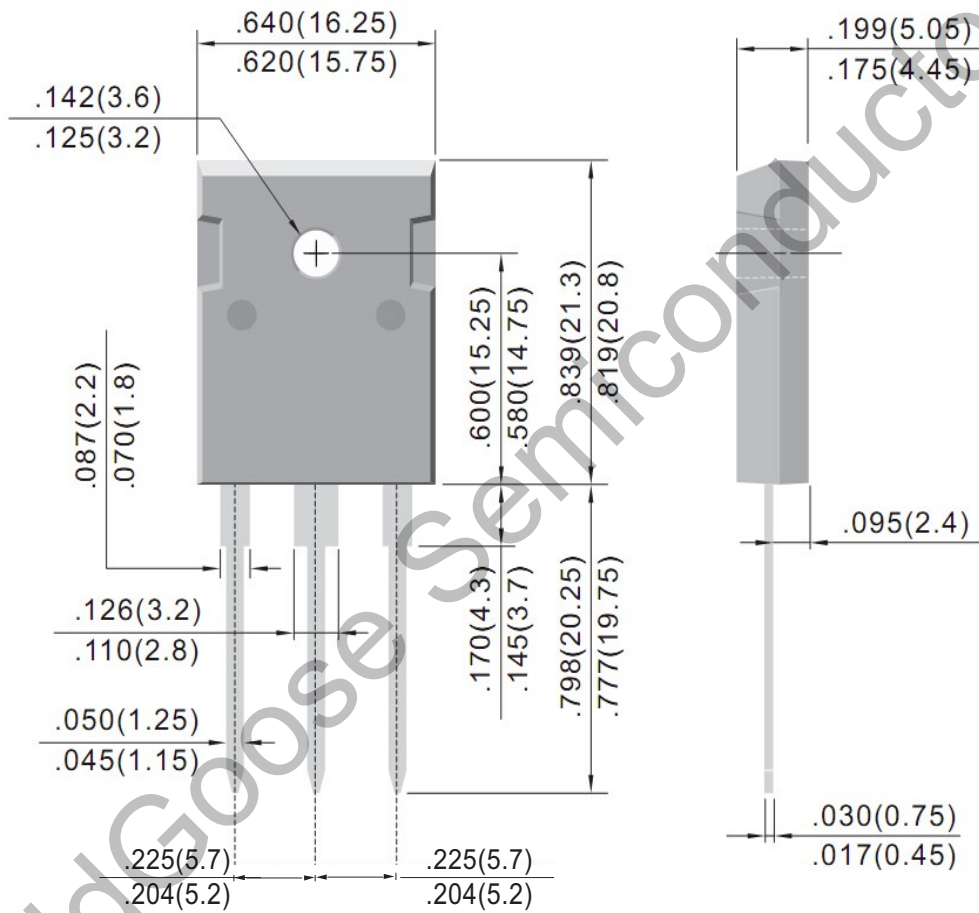

FIGURE 6. TYPICAL CURRENT DERATING CURVE vs CASE TEMPERATURE

Package Dimension

TO-247

Units: mm



## X-ON Electronics

Largest Supplier of Electrical and Electronic Components

*Click to view similar products for [Rectifiers](#) category:*

*Click to view products by [Wild Goose](#) manufacturer:*

Other Similar products are found below :

[70HFR40](#) [FR105 R0](#) [RL252-TP](#) [1N5397](#) [1N4005-TR](#) [1N4007-BP](#) [UFS120Je3/TR13](#) [20ETS12S](#) [RRE02VS6SGTR](#) [MS306](#) [A1N5404G-G](#)  
[CRF02\(T5L,TEMQ\)](#) [ACGRB207-HF](#) [CLH07\(TE16L,Q\)](#) [CLH03\(TE16L,Q\)](#) [1N5395-TP](#) [UES1302](#) [ACGRC307-HF](#) [ACEFC304-HF](#) [DZ-](#)  
[1380](#) [85HFR60](#) [40HFR60](#) [70HF120](#) [85HFR80](#) [SCF7500](#) [SM100](#) [ACGRA4001-HF](#) [SKN70/08](#) [NTE5819](#) [NTE5827](#) [NTE5828](#) [NTE5911](#)  
[NTE5915](#) [NTE6104](#) [NTE6163](#) [NTE6164](#) [NTE6165](#) [NTE6364](#) [TSD3G](#) [SET130312](#) [NRVUS110VT3G](#) [UES1106](#) [UES1306](#)  
[NRVUS240VT3G](#) [D5FE60-5063](#) [R4000GPS-TP](#) [D4015L56TP](#) [UES1306HR2](#) [FX20K120](#) [D20XB60-7101](#)