

MUR6020PT - MUR6060PT
60A SUPER FAST RECOVERY



MUR6020PT - MUR6060PT

Features:

- High Surge Capability
- Low Forward Voltage Drop
- High Current Capability
- Super Fast Switching Speed For High Efficiency



TO-247

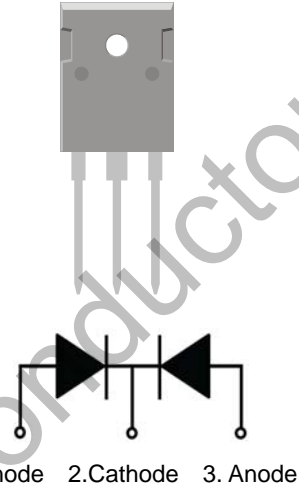

Absolute Maximum Ratings (Ta=25°C unless otherwise noted)

Rating	Symbol	MUR6020PT	MUR6040PT	MUR6060PT	Unit
Maximum Repetitive Reverse Voltage	VRRM	200	400	600	V
DC Blocking Voltage	VDC	200	400	600	V
Maximum Average Forward Current	I _{AV}	60			A
Peak Forward Surge Current ,8.3ms single half sine-wave superimposed on rated load(JEDEC method)	I _{FSM}	400			A
Maximum Forward Voltage at 30A,per element	V _F	1.05	1.40	1.80	V
Maximum DC Reverse Current at T _A =25°C	I _R	5			μA
Rated DC Blocking Voltage T _A =100°C		500			
Maximum Reverse Recovery Time (Note 1)	T _{RR}	50			ns
Maximum Thermal Resistance(Note 2)	R _{θ-JC}	3.5			°C/W
Operating Junction and Storage Temperature Range	T _J ,T _{STG}	-55 to +150			°C

NOTES:

1. Reverse Recovery Test Conditions: I_F=.5A, I_R=1A, I_{rr}=.25A.
2. Thermal resistance from junction to case.

Typical Characteristics

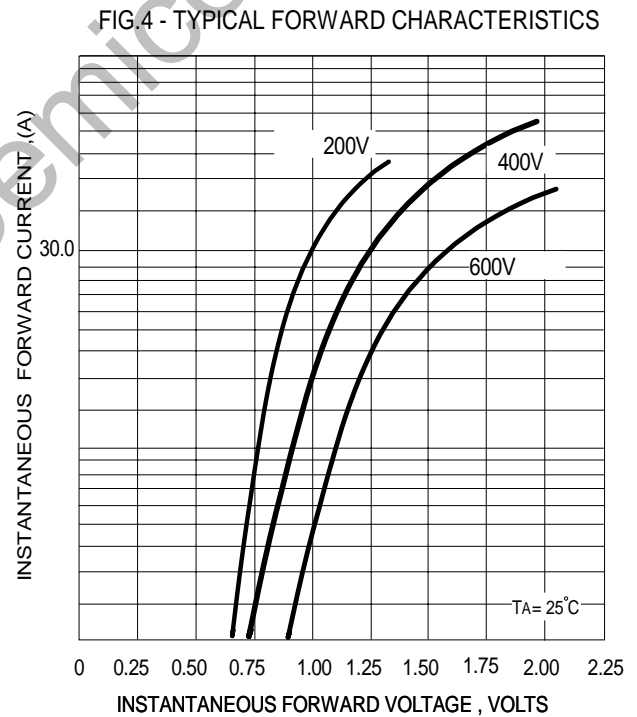
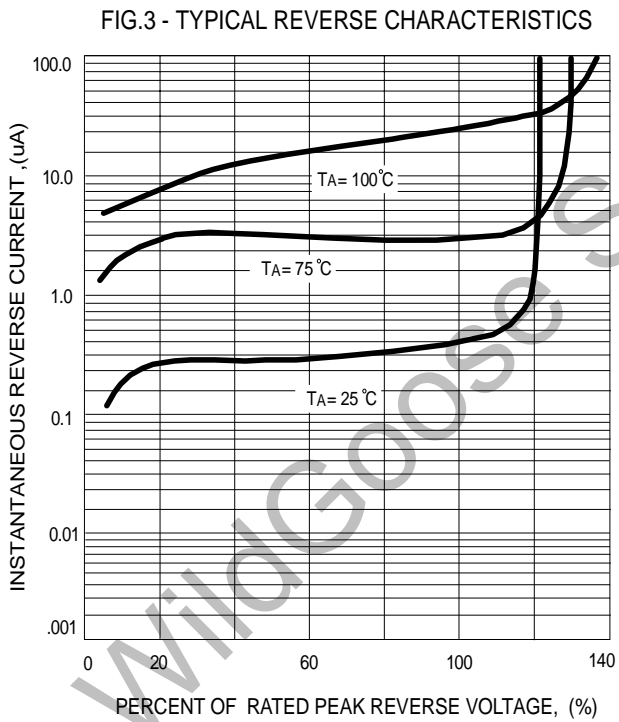
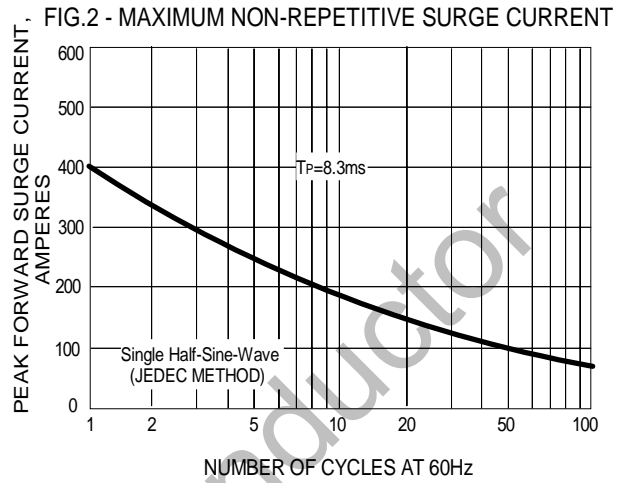
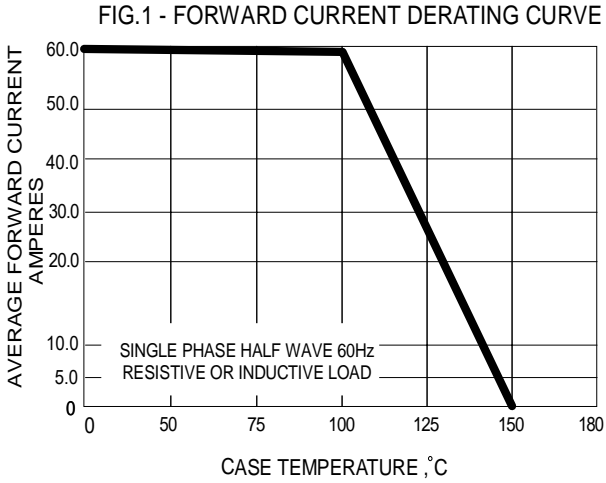

Package Dimension

TO-247

Units: mm

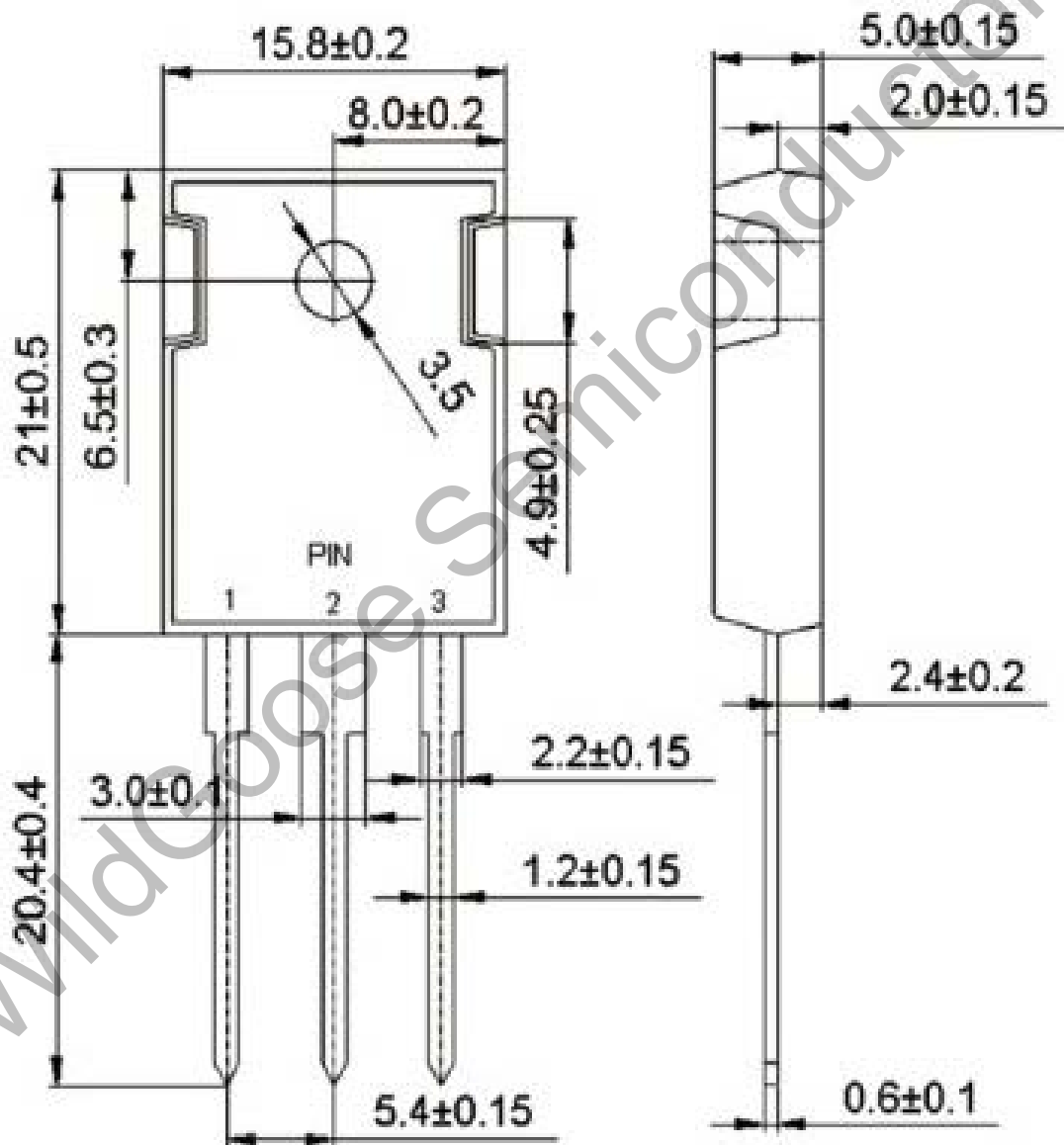

X-ON Electronics

Largest Supplier of Electrical and Electronic Components

Click to view similar products for [Rectifiers](#) category:

Click to view products by [Wild Goose](#) manufacturer:

Other Similar products are found below :

[70HFR40](#) [FR105 R0](#) [RL252-TP](#) [1N5397](#) [1N4005-TR](#) [1N4007-BP](#) [UFS120Je3/TR13](#) [20ETS12S](#) [RRE02VS6SGTR](#) [MS306](#) [A1N5404G-G](#)
[CRF02\(T5L,TEMQ\)](#) [ACGRB207-HF](#) [CLH07\(TE16L,Q\)](#) [CLH03\(TE16L,Q\)](#) [1N5395-TP](#) [UES1302](#) [ACGRC307-HF](#) [ACEFC304-HF](#) [DZ-](#)
[1380](#) [85HFR60](#) [40HFR60](#) [70HF120](#) [85HFR80](#) [SCF7500](#) [SM100](#) [ACGRA4001-HF](#) [SKN70/08](#) [NTE5819](#) [NTE5827](#) [NTE5828](#) [NTE5911](#)
[NTE5915](#) [NTE6104](#) [NTE6163](#) [NTE6164](#) [NTE6165](#) [NTE6364](#) [TSD3G](#) [SET130312](#) [NRVUS110VT3G](#) [UES1106](#) [UES1306](#)
[NRVUS240VT3G](#) [D5FE60-5063](#) [R4000GPS-TP](#) [D4015L56TP](#) [UES1306HR2](#) [FX20K120](#) [D20XB60-7101](#)