

WGC6820

Features:

- High Switching Speed
- High Breakdown Voltage- $V(BR)_{CBO}=1200V(\text{Min})$
- Minimum Lot-to-Lot variations for robust device performance and reliable operation

TO-264 

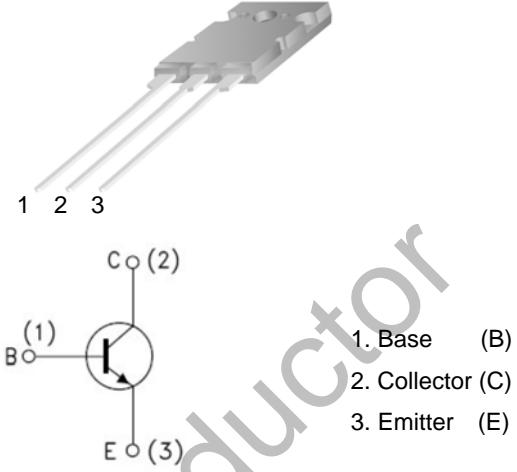

1. Base (B)
2. Collector (C)
3. Emitter (E)

ABSOLUTE RATINGS (T_c=25 °C)

Parameter		Symbol	Value	Unit
Collector-Base Voltage		BV_{CBO}	1200	V
Collector-Emitter Voltage		BV_{CEO}	750	V
Emitter-Base Voltage		BV_{EBO}	6	V
Collector Current	DC	I_C	20	A
	Pulse	I_{CP}	35	
Base Current		I_B	11	A
Collector Power Dissipation		P_C	140	W
Max. Junction Temperature		T_j	150	
Storage Temperature Range		T_{STG}	-55~+150	

ELECTRICAL CHARACTERISTICS (T_c=25)

Parameter	Tests conditions	Min	Max	Unit
V(BR) _{CEO}	I _C =5mA, I _B =0	750		V
V(BR) _{CBO}	I _C =500uA, I _E =0	1200		V
V(BR) _{EBO}	I _E =500uA, I _C =0	6		V
I _{CBO}	V _{CB} =800V, I _E =0		10	μA
I _{EBO}	V _{EB} = 4V, I _C =0		1	mA
H _{FE}	V _{CE} = 5 V, I _C = 1A	8		
	V _{CE} = 5 V, I _C = 11 A	5.5	8.5	
V _{CE(sat)}	I _C =11A, I _B =2.75A		3	V
V _{BE(sat)}	I _C =11A, I _B =2.75A		1.5	V
tf	V _{CC} =200V, I _C =10A, R _L =20Ω		0.2	μs
ts	I _{B1} =2.0A, I _{B2} =-4.0A		3	μs

Thermal Characteristics

Symbol	Parameter	Typ.	Max.	Unit
R _{θJC}	Thermal Resistance, Junction to Case	-	2.08	°C/W

Typical Characteristics

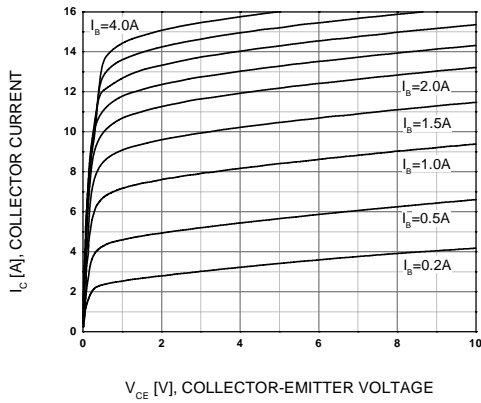

Figure 1. Static Characteristics

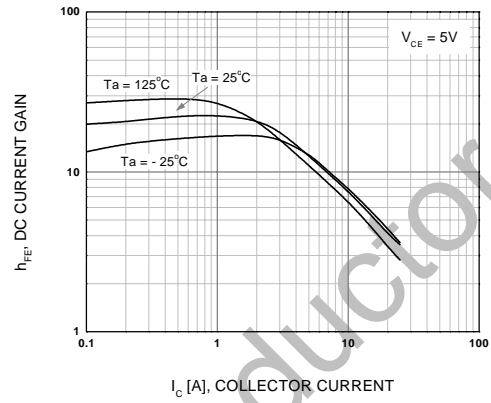

Figure 2. DC Current Gain

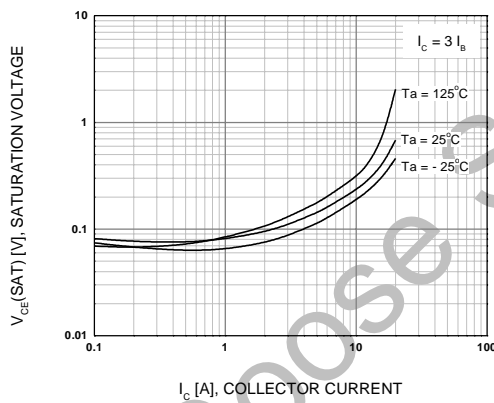

Figure 3. Collector-Emitter Saturation Voltage

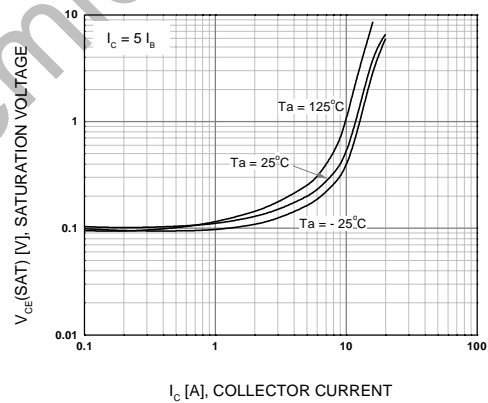

Figure 4. Collector-Emitter Saturation Voltage

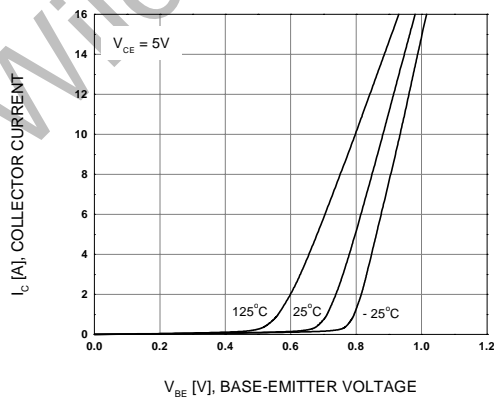

Figure 5. Base-Emitter On Voltage

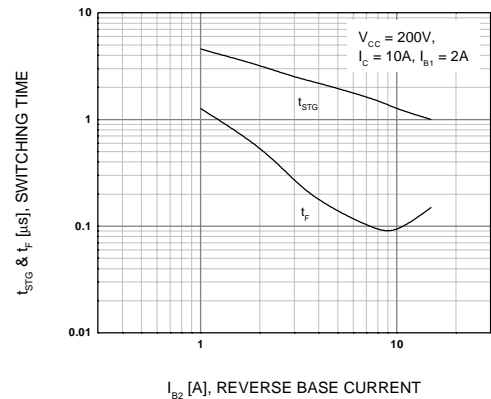

Figure 6. Resistive Load Switching Time

Typical Characteristics

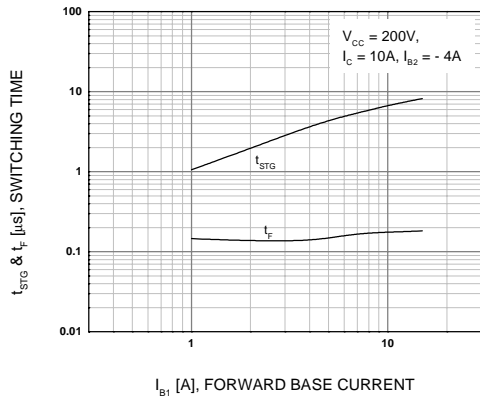

Figure 7. Resistive Load Switching Time

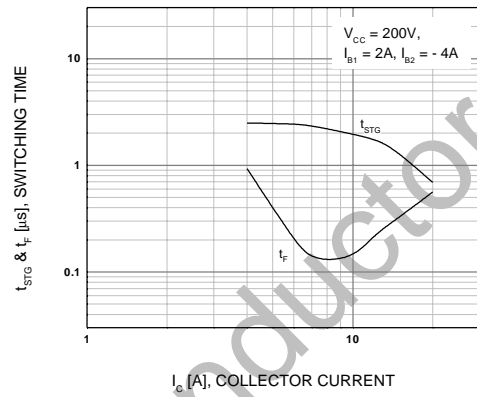

Figure 8. Resistive Load Switching Time

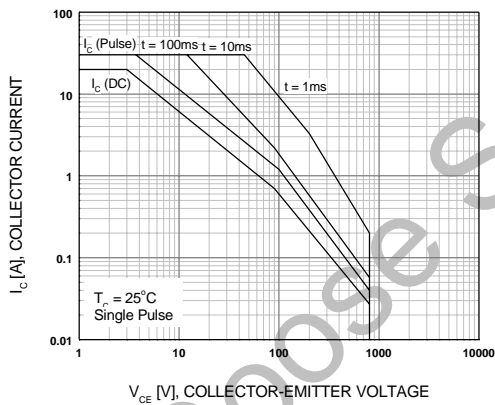

Figure 9. Forward Bias Safe Operating Area

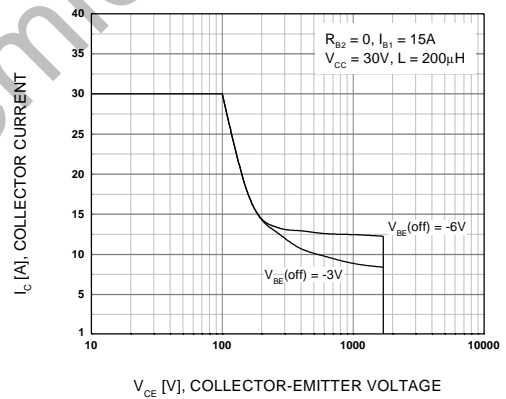

Figure 10. Reverse Bias Safe Operating Area

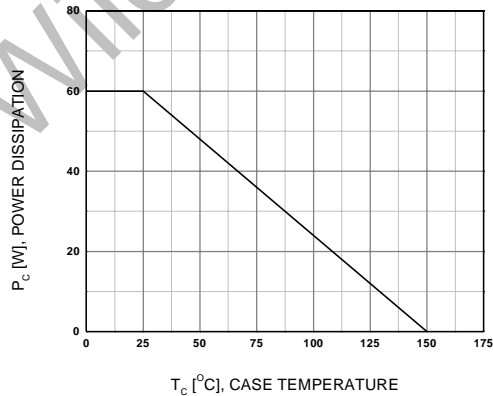
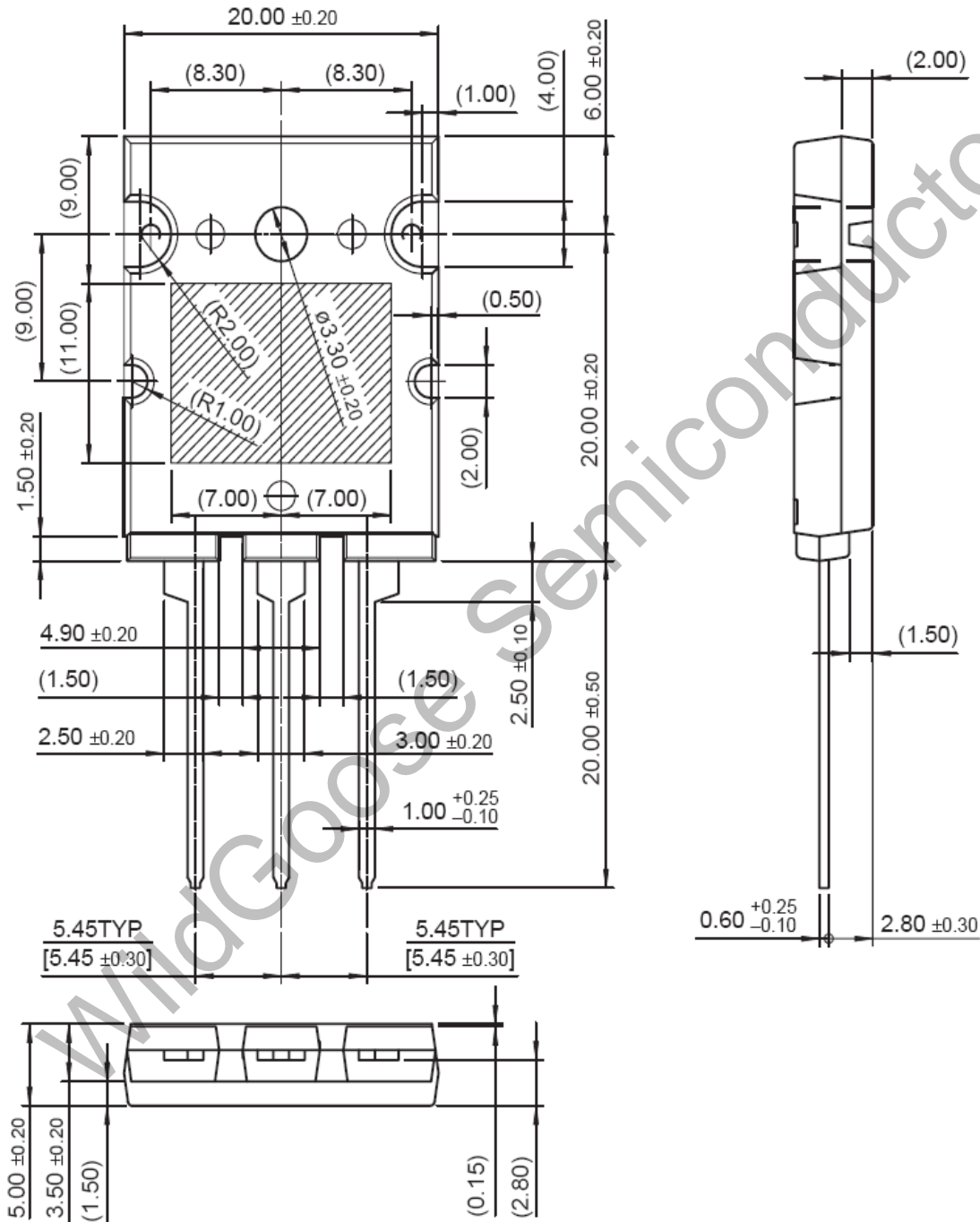

Figure 11. Power Derating

Package Dimension

TO-264

Unit: mm



X-ON Electronics

Largest Supplier of Electrical and Electronic Components

Click to view similar products for [Bipolar Transistors - BJT category](#):

Click to view products by [Wild Goose manufacturer](#):

Other Similar products are found below :

[BC559C](#) [MCH4017-TL-H](#) [MMBT-2369-TR](#) [BC546/116](#) [NJVMJD148T4G](#) [NTE16](#) [NTE195A](#) [IMX9T110](#) [2N4401-A](#) [2N6728](#) [2SA1419T-TD-H](#) [2SB1204S-TL-E](#) [2SC5488A-TL-H](#) [FMC5AT148](#) [2N2369ADCSM](#) [2N2907A](#) [2N3904-NS](#) [2N5769](#) [2SC4618TLN](#) [CPH6501-TL-E](#) [US6T6TR](#) [BAX18/A52R](#) [BC556/112](#) [IMZ2AT108](#) [MMST8098T146](#) [MCH6102-TL-E](#) [BC846B-13-F](#) [2N3879](#) [30A02MH-TL-E](#) [NTE13](#) [NTE282](#) [NTE323](#) [NTE350](#) [NTE81](#) [JANTX2N2920L](#) [JANSR2N2907AUB](#) [CMLT3946EG TR](#) [SNSS40600CF8T1G](#) [CMLT3906EG TR](#) [GRP-DATA-JANS2N2907AUB](#) [GRP-DATA-JANS2N2222AUA](#) [MMDT3946FL3-7](#) [2N4240](#) [JANS2N3019](#) [MSB30KH-13](#) [2N2221AUB](#) [2SD1815T-TL-E](#) [2N6678](#) [2N2907Ae4](#) [JAN2N3507](#)