

WGD50N03
30V N-Channel MOSFET

Features:

- Low Intrinsic Capacitances.
- Excellent Switching Characteristics.
- Extended Safe Operating Area.
- Unrivalled Gate Charge :Qg=23.6 nC (Typ.).
- BVDSS=30V, I_D=50A
- R_{DS(on)} : 7.3mΩ (Max) @V_G=10V
- 100% Avalanche Tested

TO-252 

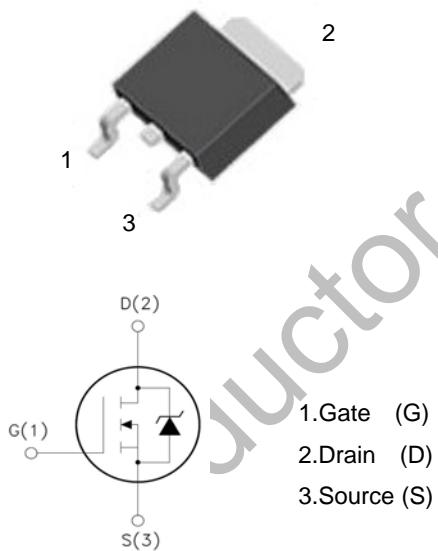

1.Gate (G)
2.Drain (D)
3.Source (S)

Absolute Maximum Ratings (T_A=25°C unless otherwise noted)

Symbol	Parameter	Maximum	Unit
V _{DSS}	Drain-to-Source Voltage	30	V
V _{GSS}	Gate-to-Source Voltage	±20	V
I _D	Continuous Drain Current	T _C =25°C	50
		T _C =100°C	35
I _{DP}	Pulsed Drain Current	T _C =25°C	150
PD	Maximum Power Dissipation	T _C =25°C	34
		T _C =100°C	17
T _J , T _{STG}	Junction & Storage Temperature Range	-55~150	°C

Thermal Characteristics

Symbol	Parameter	Typical	Unit
Rθ _{jc}	Thermal Resistance-Junction to Case	2.1	°C/W
Rθ _{ja}	Thermal Resistance-Junction to Ambient	62.5	

Electrical Characteristics (TA=25°C unless otherwise noted)

Symbol	Parameter	Test Conditions	Min.	Typ	Max.	Unit
Static Characteristics						
BV_{DSS}	Drain-Source Breakdown Voltage	$V_{GS}=0V, I_D=250\mu A$	30	—	—	V
I_{DSS}	Zero Gate Voltage Drain Current	$V_{DS}=30V, V_{GS}=0V$	—	—	1	μA
		$T_J=85^\circ C$	—	—	10	
$V_{GS(th)}$	Gate Threshold Voltage	$V_{DS}=V_{GS}, I_D=250\mu A$	1	1.5	3	V
I_{GSS}	Gate Leakage Current	$V_{GS}=\pm 20V, V_{DS}=0V$	—	—	± 100	nA
$R_{DS(on)}^1$	Drain-Source On-Resistance	$V_{GS}=10V, I_D=15A$	—	5.4	7.3	m Ω
		$V_{GS}=4.5V, I_D=15A$	—	9.5	11.5	
Diode Characteristics						
V_{SD}^1	Diode Forward Voltage	$I_{SD}=15A, V_{GS}=0V$	—	0.9	1.2	V
I_S	Diode Continuous Forward Current				50	A
t_{rr}	Reverse Recovery Time	$I_F=15A,$	—	35		ns
Q_{rr}	Reverse Recovery Charge	$di/dt=100A/\mu s$	—	23.6		nC
Dynamic Characteristics²						
R_G	Gate Resistance	$V_{GS}=0V, V_{DS}=0V,$ Frequency=1MHz	—	1.3	—	Ω
C_{iss}	Input Capacitance	$V_{GS}=0V, V_{DS}=15V$ Frequency=1MHz	—	1015		pF
C_{oss}	Output Capacitance		—	201		
C_{rss}	Reverse Transfer Capacitance		—	164		
$t_{d(on)}$	Turn-On Delay Time	$V_{DD}=20V, R_L=3\Omega$ $I_D=2A, V_{GS}=10V$ $R_G=3\Omega$	—	7.0		ns
t_r	Turn-On Rise Time		—	19		
$t_{d(off)}$	Turn-Off Delay Time		—	24		
t_f	Turn-Off Fall Time		—	24		
Gate Charge Characteristics²						
Q_g	Total Gate Charge	$V_{DS}=12.5V, V_{GS}=10V$ $I_D=20A$	—	23.6		nC
Q_{gs}	Gate-to-Source Charge		—	3.9		
Q_{gd}	Gate-to-Drain Charge		—	7.0		

Note: 1: Pulse test; pulse width $\leq 300ns$, duty cycle $\leq 2\%$.

2: Guaranteed by design, not subject to production testing.

Typical Characteristics

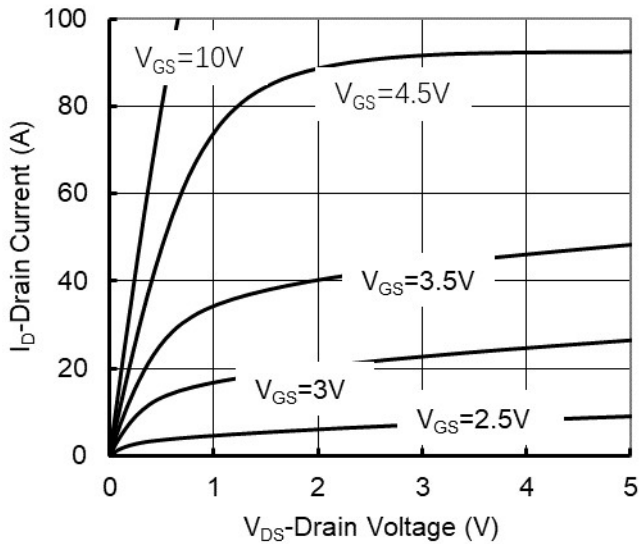

Figure 1. Output Characteristics

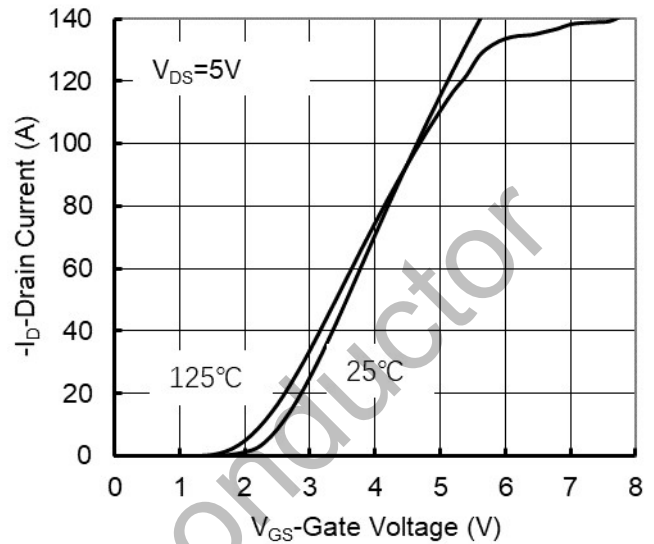

Figure 2. Transfer Characteristics

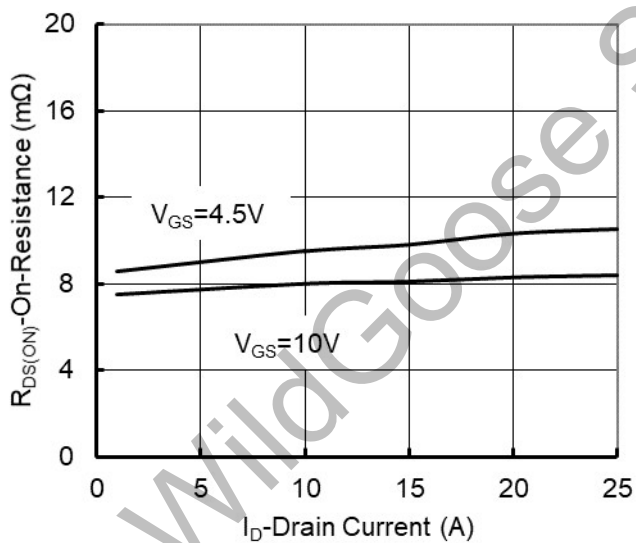

Figure 3. On-Resistance vs. Drain Current and Gate Voltage

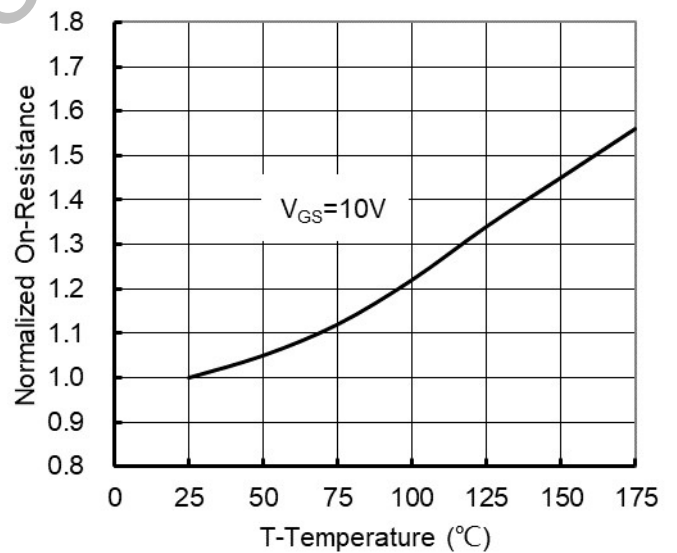

Figure 4. On-Resistance vs. Junction Temperature

Typical Characteristics

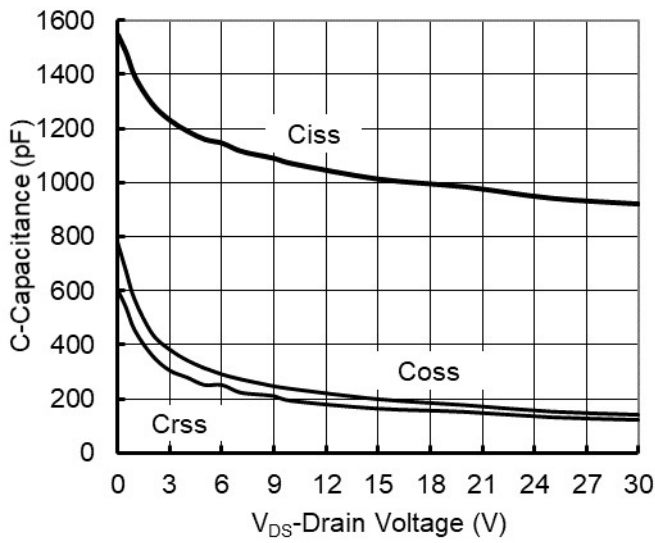

Figure 5. Capacitance Characteristics

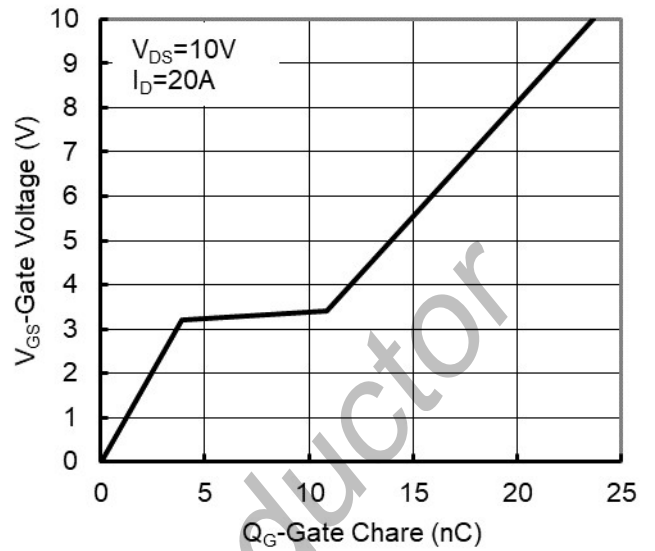

Figure 6. Gate Charge

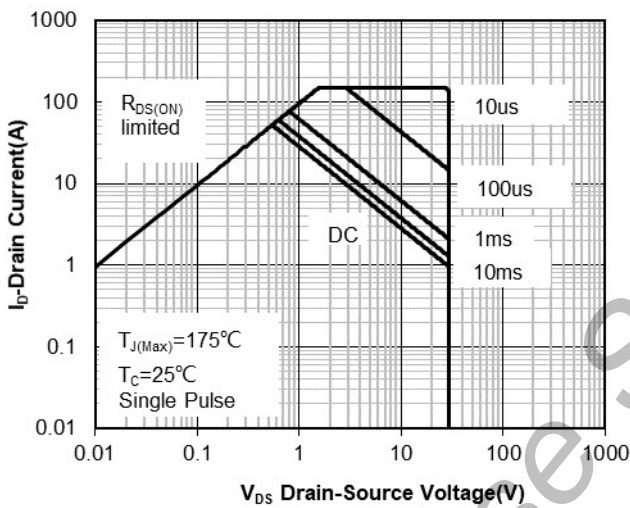

Figure 7. Safe Operation Area

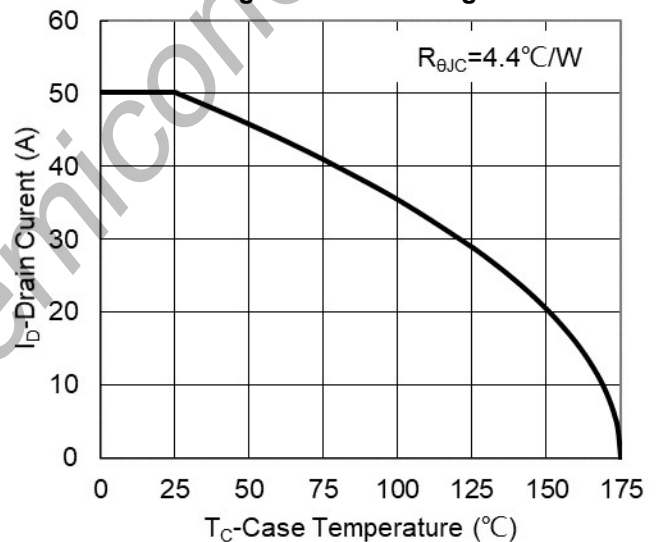

Figure 8. Maximum Continuous Drain Current vs Case Temperature

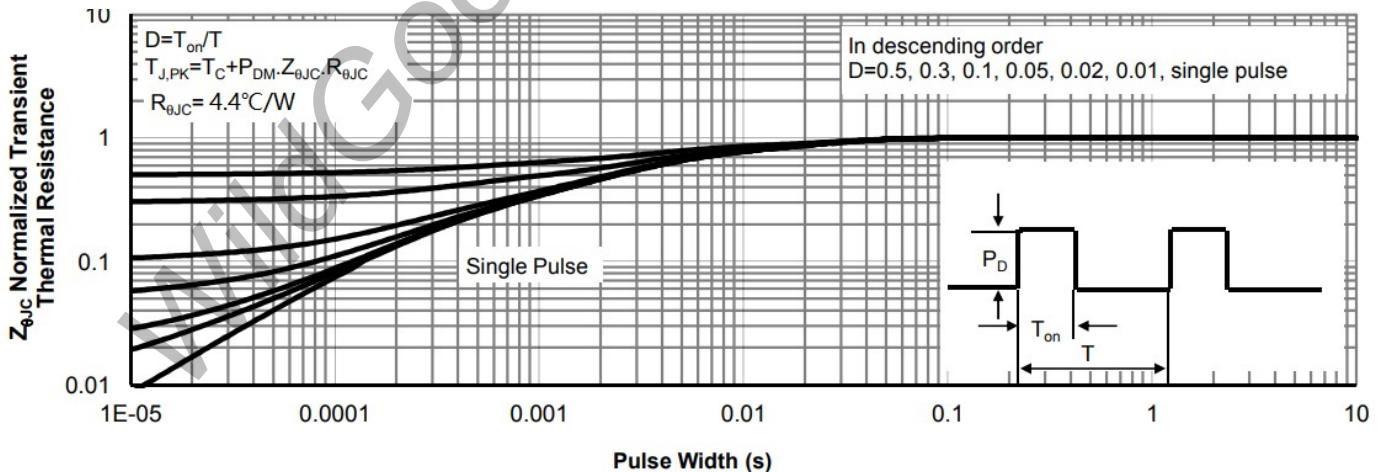
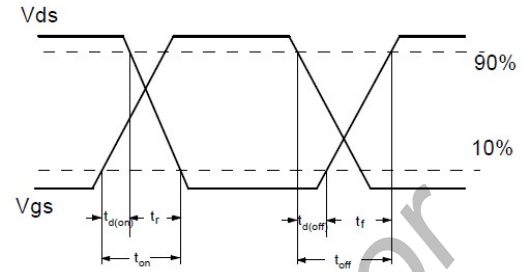
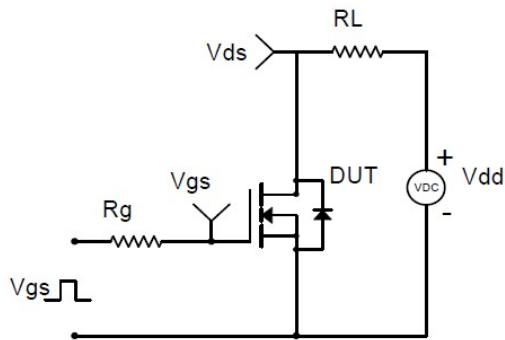
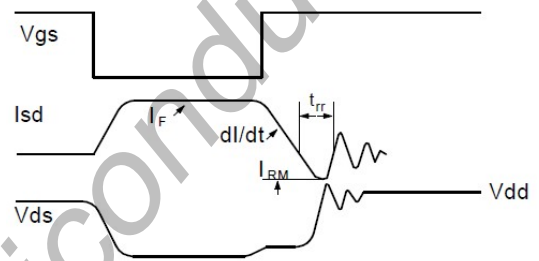
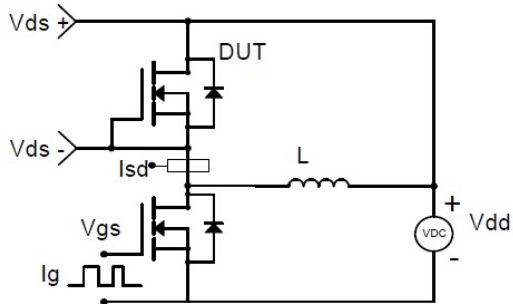

Figure 9. Normalized Maximum Transient Thermal Impedance



Resistive Switching Test Circuit & Waveforms



Diode Recovery Test Circuit & Waveforms

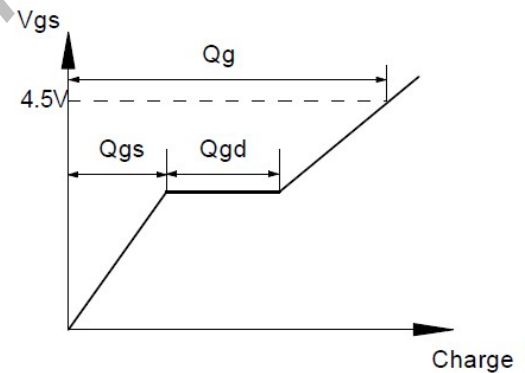
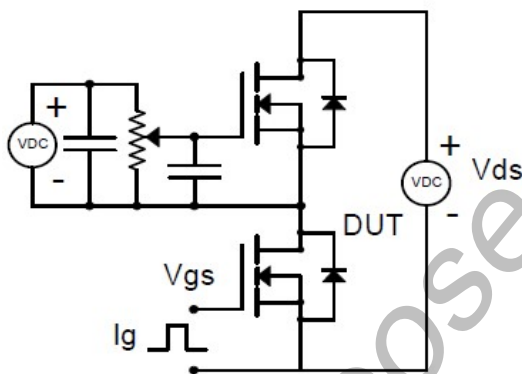

Gate Charge Test Circuit & Waveform

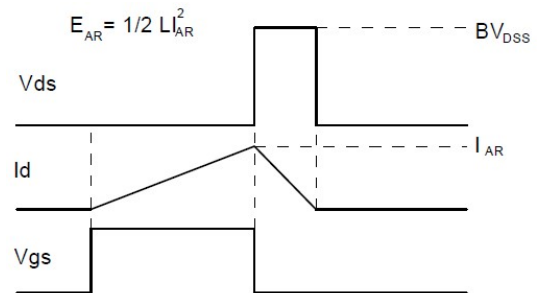
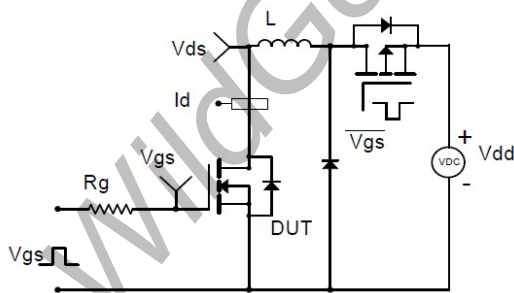

Unclamped Inductive Switching (UIS) Test Circuit & Waveforms

Package Dimension

TO-252

Unit: mm

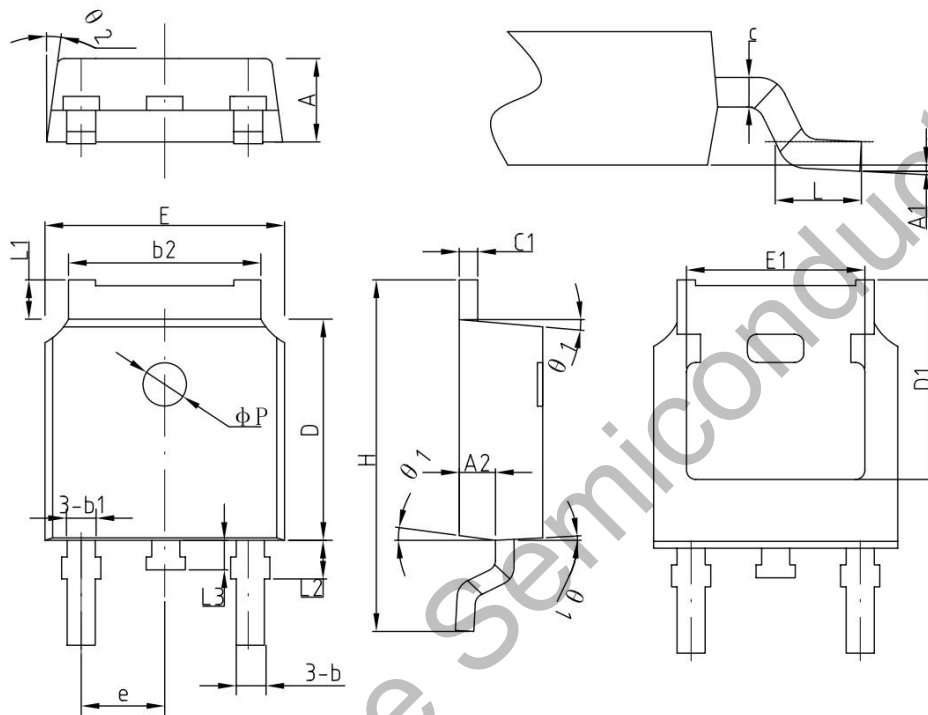

COMMON DIMENSIONS
(UNITS OF MEASURE=MILLIMETER)

SYMBOL	MIN	NOM	MAX
A	2.2	2.30	2.38
A1	0	-	0.10
A2	0.90	1.01	1.10
b	0.71	0.76	0.86
b1		0.76	
b2	5.13	5.33	5.46
c	0.47	0.50	0.60
c1	0.47	0.50	0.60
D	6.0	6.10	6.20
D1	-	5.30	-
E	6.50	6.60	6.70
E1	-	4.80	-
e	2.286BSC		
H	9.70	10.10	10.40
L	1.40	1.50	1.70
L1	0.90	-	1.25
L2		1.05	
L3		0.8	
φP		1.2	
θ	0°	-	8°
θ 1	5°	7°	9°
θ 2	5°	7°	9°

X-ON Electronics

Largest Supplier of Electrical and Electronic Components

Click to view similar products for [MOSFET](#) category:

Click to view products by [Wild Goose](#) manufacturer:

Other Similar products are found below :

[IRFD120](#) [JANTX2N5237](#) [BUK455-60A/B](#) [MIC4420CM-TR](#) [VN1206L](#) [NDP4060](#) [SI4482DY](#) [IPS70R2K0CEAKMA1](#) [SQD23N06-31L-GE3](#)
[TK16J60W,S1VQ\(O](#) [2SK2614\(TE16L1,Q\)](#) [DMN1017UCP3-7](#) [DMN1053UCP4-7](#) [SQJ469EP-T1-GE3](#) [NTE2384](#) [DMC2700UDMQ-7](#)
[DMN2080UCB4-7](#) [DMN61D9UWQ-13](#) [US6M2GTR](#) [DMN31D5UDJ-7](#) [DMP22D4UFO-7B](#) [DMN1006UCA6-7](#) [DMN16M9UCA6-7](#)
[STF5N65M6](#) [IRF40H233XTMA1](#) [STU5N65M6](#) [DMN6022SSD-13](#) [DMN13M9UCA6-7](#) [DMTH10H4M6SPS-13](#) [DMN2990UFB-7B](#)
[IPB80P04P405ATMA2](#) [2N7002W-G](#) [MCAC30N06Y-TP](#) [MCQ7328-TP](#) [BXP7N65D](#) [BXP4N65F](#) [AOL1454G](#) [WMJ80N60C4](#) [BXP2N20L](#)
[BXP2N65D](#) [BXT1150N10J](#) [BXT1700P06M](#) [TSM60NB380CP](#) [ROG](#) [RQ7L055BGTCR](#) [DMNH15H110SK3-13](#) [SLF10N65ABV2](#)
[BSO203SP](#) [BSO211P](#) [IPA60R230P6](#) [IPA60R460CE](#)