



## WGD7N65SE

## Features:

- Low Intrinsic Capacitances.
- Excellent Switching Characteristics.
- Extended Safe Operating Area.
- Unrivalled Gate Charge : $Q_g=29\text{nC}$  (Typ.).
- $V_{DSS}=650\text{ V}, I_D=7\text{ A}$
- $R_{DS(on)} : 1.35\Omega$  (Max) @ $V_G=10\text{ V}$
- 100% Avalanche Tested



TO-252

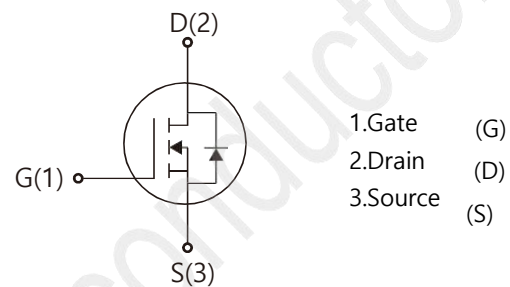
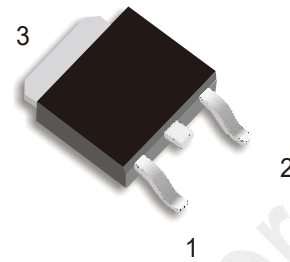

## Absolute Maximum Ratings (Ta=25°C unless otherwise noted)

Symbol	Parameter	Value	Unit
$V_{DSS}$	Drain-Source Voltage	650	V
$I_D$	Drain Current	$T_j=25^\circ\text{C}$	7.0
		$T_j=100^\circ\text{C}$	4.7
$V_{GSS}$	Gate-Source Voltage	$\pm 30$	V
$E_{AS}$	Single Pulse Avalanche Energy (note1)	300	mJ
$I_{AR}$	Avalanche Current (note2)	7.0	A
$P_D$	Power Dissipation ( $T_j=25^\circ\text{C}$ )	50	W
$T_j$	Junction Temperature(Max)	150	$^\circ\text{C}$
$T_{stg}$	Storage Temperature	-55~+150	$^\circ\text{C}$
TL	Maximum lead temperature for soldering purpose,1/8' from case for 5 seconds	300	$^\circ\text{C}$

## Thermal Characteristics

Symbol	Parameter	Typ.	Max.	Unit
$R_{\theta JC}$	Thermal Resistance,Junction to Case	-	2.4	$^\circ\text{C}/\text{W}$
$R_{\theta JA}$	Thermal Resistance,Junction to Ambient	-	62.5	$^\circ\text{C}/\text{W}$

## Electrical Characteristics (Ta=25°C unless otherwise noted)

Symbol	Parameter	Test Condition	Min.	Typ.	Max.	Unit
Off Characteristics						
$BV_{DSS}$	Drain-Source Breakdown Voltage	$I_D=250\mu A, V_{GS}=0$	650	-	-	V
$\Delta BV_{DSS}/\Delta T_J$	Breakdown Voltage Temperature Coefficient	$I_D=250\mu A$ , Reference to 25°C	-	0.67	-	V/°C
$I_{DSS}$	Zero Gate Voltage Drain Current	$V_{DS}=650V, V_{GS}=0V$	-	-	10	$\mu A$
		$V_{DS}=520V, T_J=125^\circ C$	-	-	100	
$I_{GSSF}$	Gate-body leakage Current, Forward	$V_{GS}=+30V, V_{DS}=0V$	-	-	100	nA
$I_{GSSR}$	Gate-body leakage Current, Reverse	$V_{GS}=-30V, V_{DS}=0V$	-	-	-100	
On Characteristics						
$V_{GS(TH)}$	Gate Threshold Voltage	$I_D=250\mu A, V_{DS}=V_{GS}$	2	-	4	V
$R_{DS(ON)}$	Static Drain-Source On-Resistance	$I_D=3.5A, V_{GS}=10V$	-	1.25	1.35	$\Omega$
Dynamic Characteristics						
$C_{iss}$	Input Capacitance	$V_{DS}=25V, V_{GS}=0, f=1.0MHz$	-	1000	-	$\mu F$
$C_{oss}$	Output Capacitance		-	95	-	
$C_{rss}$	Reverse Transfer Capacitance		-	2.4	-	
Switching Characteristics						
$T_d(on)$	Turn-On Delay Time	$V_{DD}=325V, I_D=7A, R_G=25\Omega$ (Note 3,4)	-	30	70	nS
$T_r$	Turn-On Rise Time		-	80	170	
$T_d(off)$	Turn-Off Delay Time		-	65	140	
$T_f$	Turn-Off Rise Time		-	60	130	
$Q_g$	Total Gate Charge	$V_{DS}=520V, V_{GS}=10V, I_D=7A$ (Note 3,4)	-	29	38	nC
$Q_{gs}$	Gate-Source Charge		-	7	-	
$Q_{gd}$	Gate-Drain Charge		-	14.5	-	
Drain-Source Diode Characteristics and Maximum Ratings						
$I_S$	Max. Diode Forward Current	-	-	-	7	A
$I_{SM}$	Max. Pulsed Forward Current	-	-	-	28	
$V_{SD}$	Diode Forward Voltage	$I_D=7A$	-	-	1.4	V
$T_{rr}$	Reverse Recovery Time	$I_S=7A, V_{GS}=0V, diF/dt=100A/\mu s$ (Note 3)	-	293	-	nS
$Q_{rr}$	Reverse Recovery Charge	(Note 3)	-	1.7	-	$\mu C$

Notes : 1, L=0.5mH, IAS= 7A, VDD=50V, RG=25 $\Omega$ , Starting T<sub>J</sub> =25°C

2, Repetitive Rating : Pulse width limited by maximum junction temperature

3, Pulse Test : Pulse Width  $\leq 300\mu s$ , Duty Cycle  $\leq 2\%$

4, Essentially Independent of Operating Temperature

Typical Characteristics

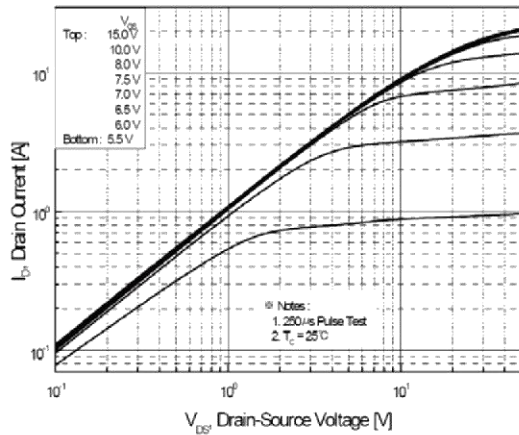

Figure 1. On-Region Characteristics

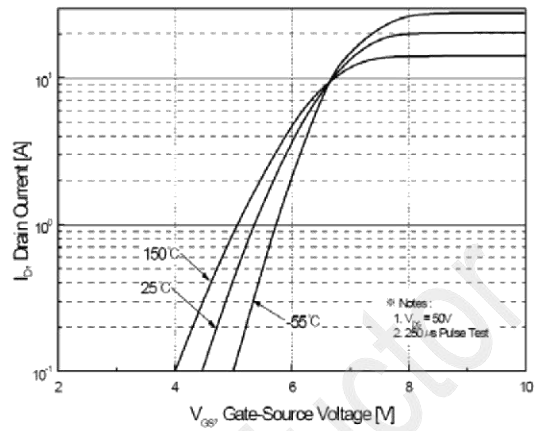

Figure 2. Transfer Characteristics

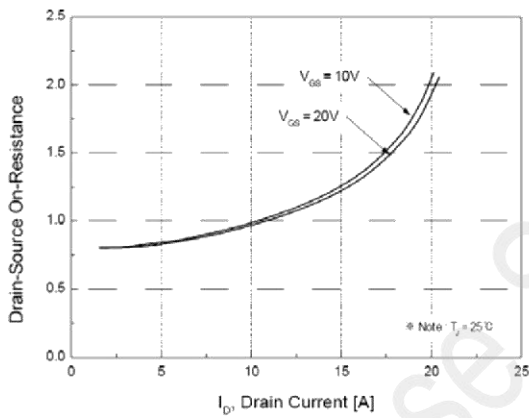

Figure 3. On-Resistance Variation vs. Drain Current and Gate Voltage

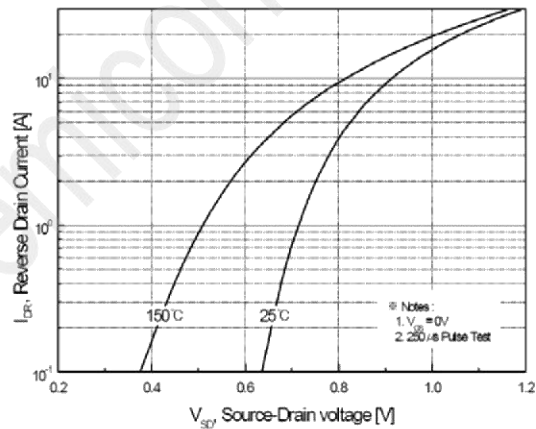

Figure 4. Body Diode Forward Voltage Variation vs. Source Current and Temperature

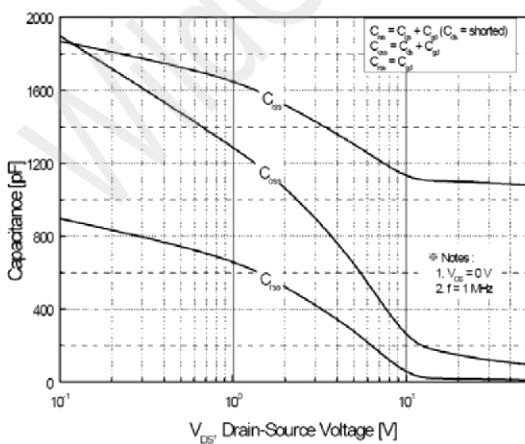

Figure 5. Capacitance Characteristics

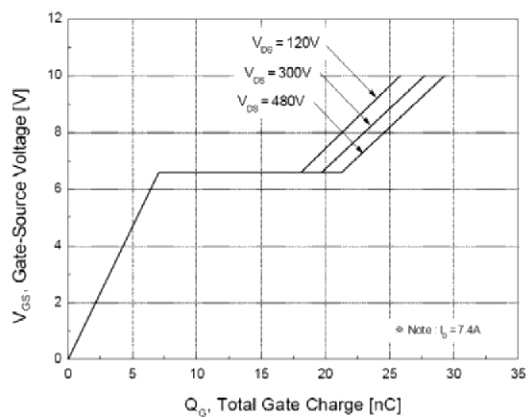

Figure 6. Gate Charge Characteristics

Typical Characteristics (Continued)

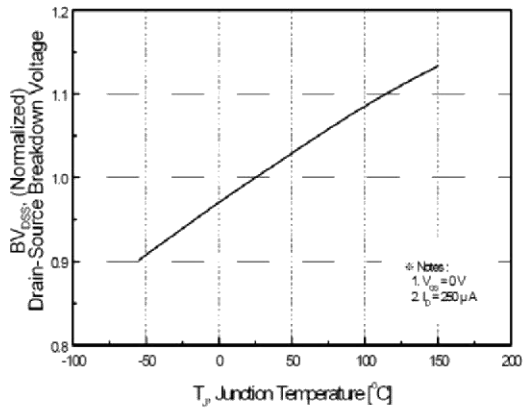

Figure 7. Breakdown Voltage Variation vs Temperature

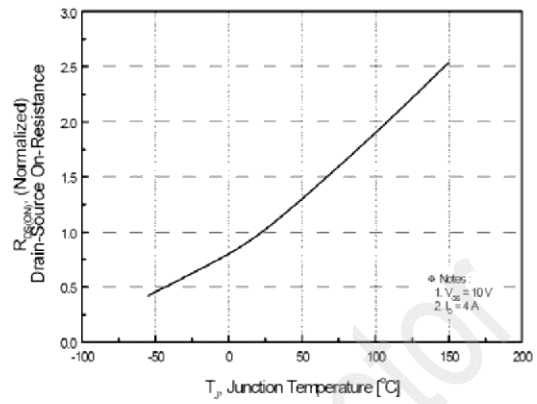

Figure 8. On-Resistance Variation vs Temperature

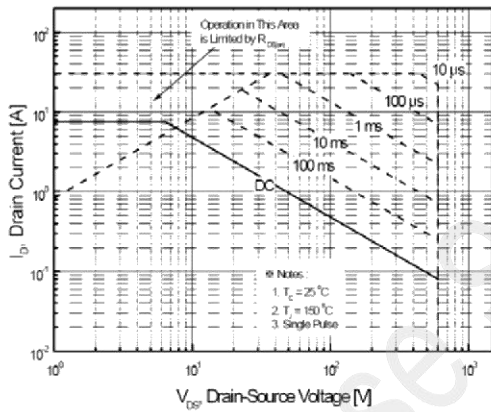

Figure 9-2. Maximum Safe Operating Area

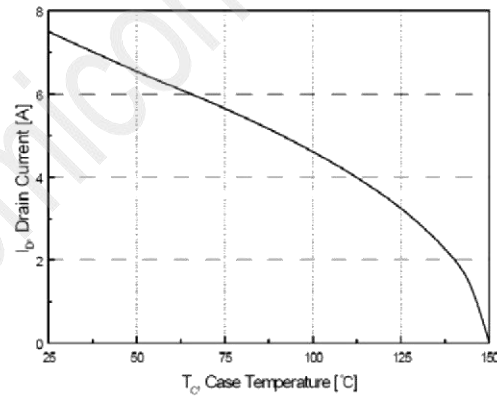

Figure 10. Maximum Drain Current vs Case Temperature

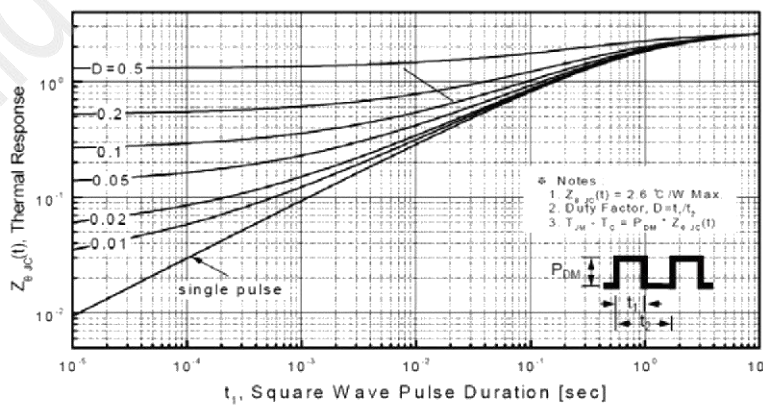
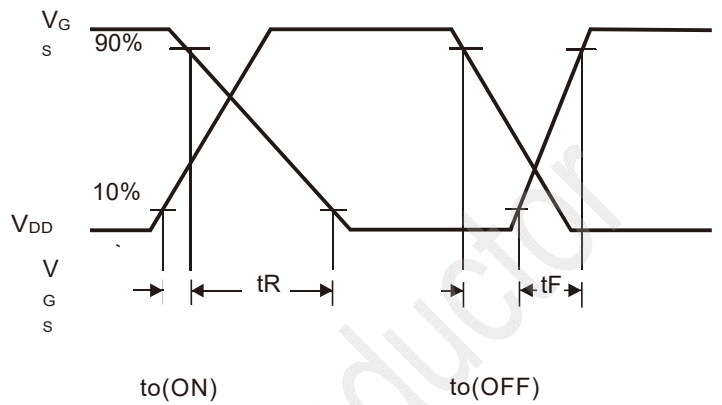
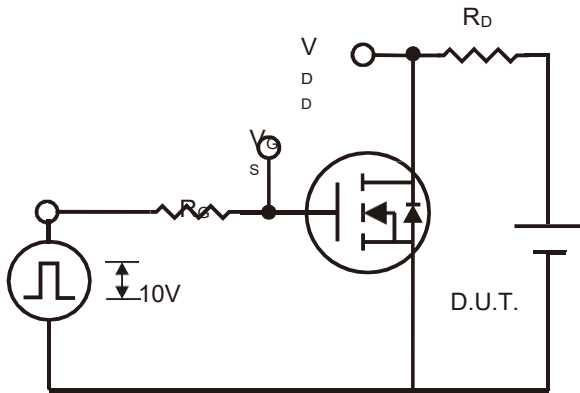
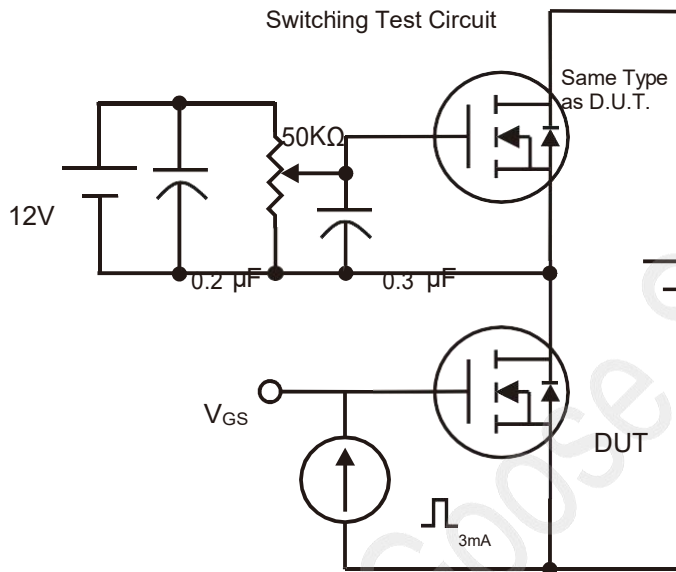

Figure 11-2. Transient Thermal Response Curve

Gate Charge Test Circuit & Waveform



Switching Test Circuit



Switching Waveforms

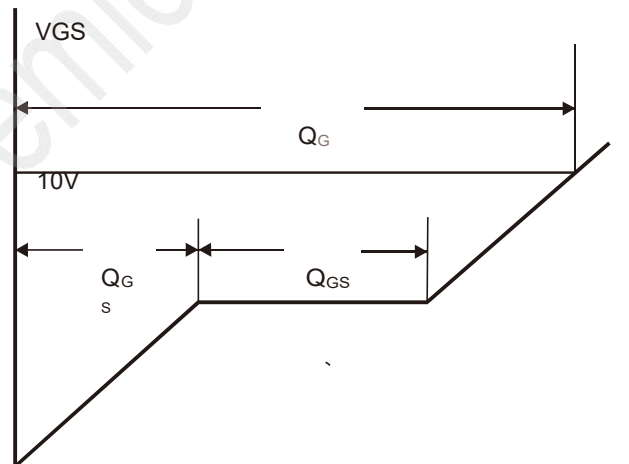

Gate Charge Test Circuit

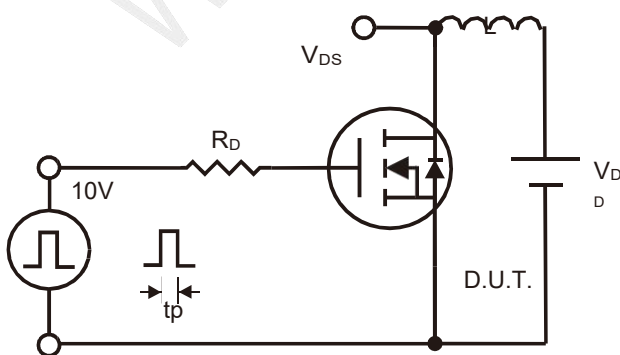

Gate Charge Waveform

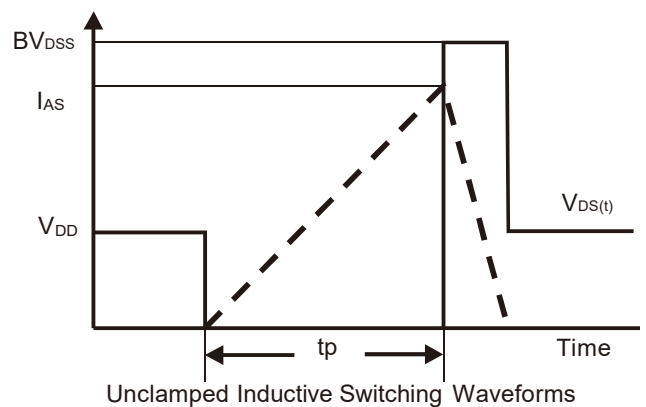

Unclamped Inductive Switching Test Circuit

Unclamped Inductive Switching Waveforms

Peak Diode Recovery dv/dt Test Circuit & Waveform

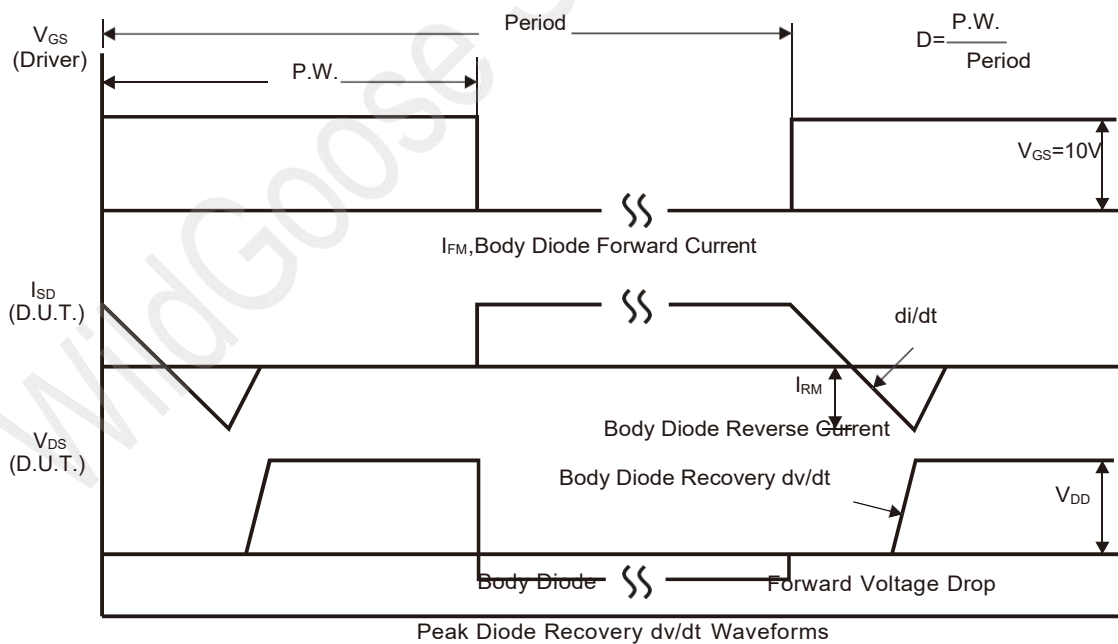
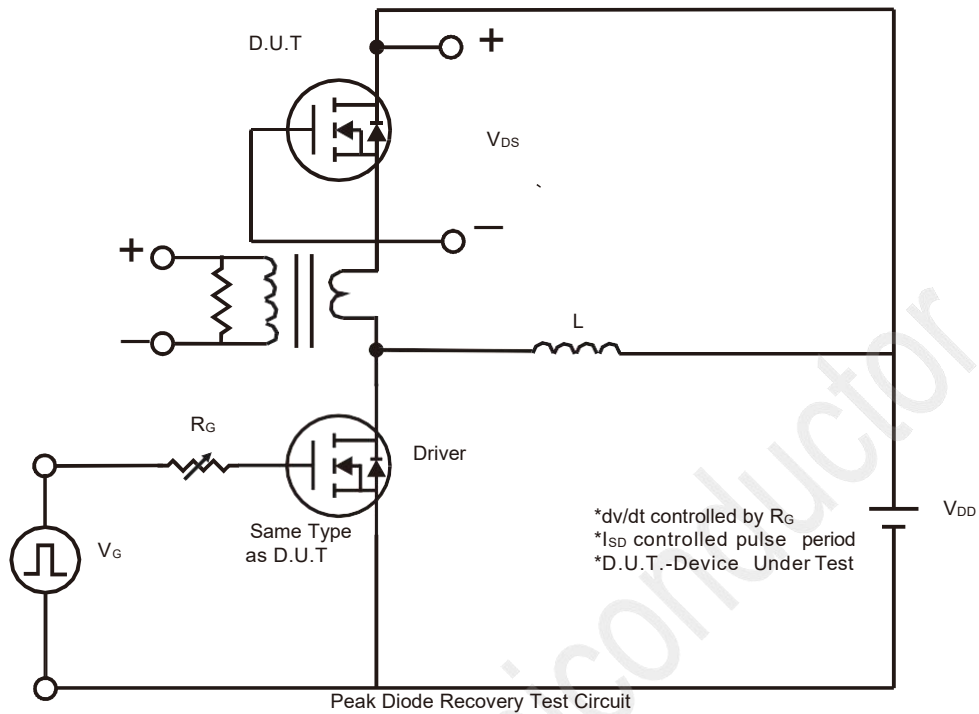

Package Dimension

TO-252

Unit: mm

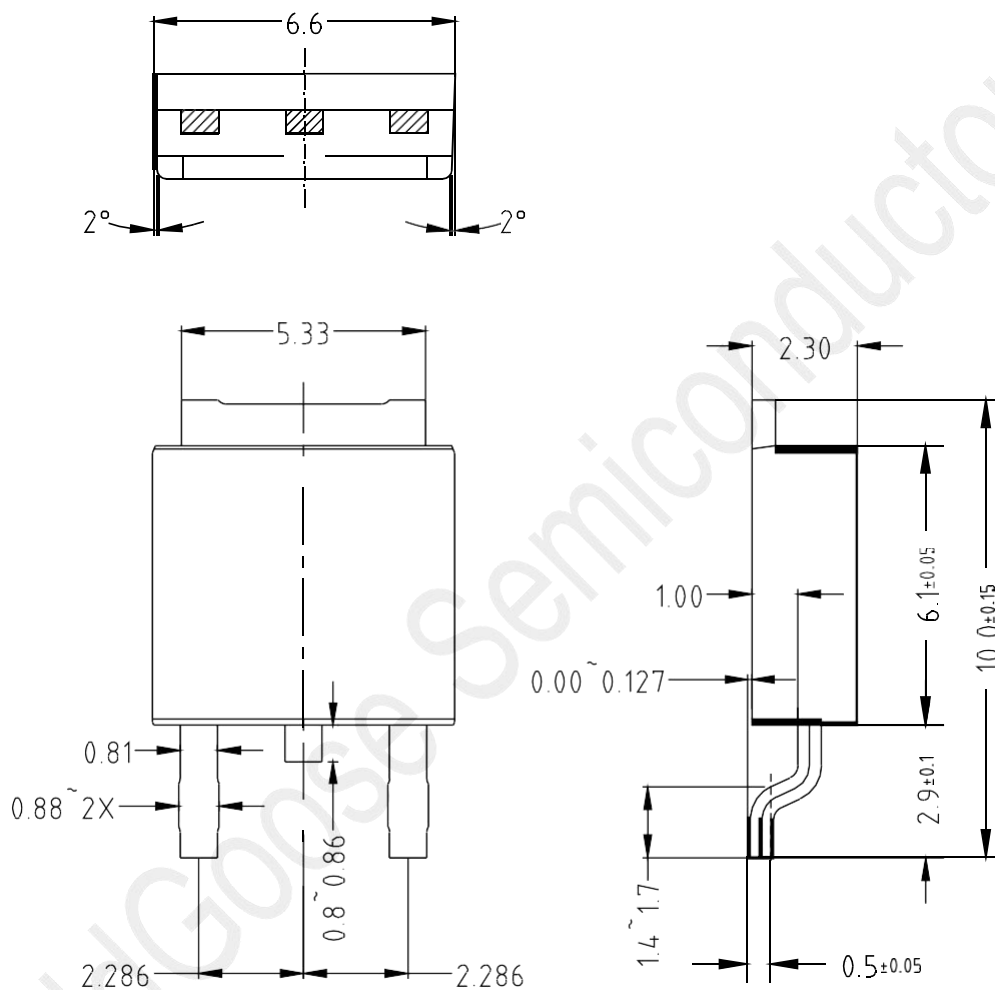

## X-ON Electronics

Largest Supplier of Electrical and Electronic Components

*Click to view similar products for [MOSFET](#) category:*

*Click to view products by [Wild Goose](#) manufacturer:*

Other Similar products are found below :

[IRFD120](#) [JANTX2N5237](#) [BUK455-60A/B](#) [MIC4420CM-TR](#) [VN1206L](#) [NDP4060](#) [SI4482DY](#) [IPS70R2K0CEAKMA1](#) [SQD23N06-31L-GE3](#)  
[TK16J60W,S1VQ\(O](#) [2SK2614\(TE16L1,Q\)](#) [DMN1017UCP3-7](#) [DMN1053UCP4-7](#) [SQJ469EP-T1-GE3](#) [NTE2384](#) [DMC2700UDMQ-7](#)  
[DMN2080UCB4-7](#) [DMN61D9UWQ-13](#) [US6M2GTR](#) [DMN31D5UDJ-7](#) [DMP22D4UFO-7B](#) [DMN1006UCA6-7](#) [DMN16M9UCA6-7](#)  
[STF5N65M6](#) [IRF40H233XTMA1](#) [STU5N65M6](#) [DMN6022SSD-13](#) [DMN13M9UCA6-7](#) [DMTH10H4M6SPS-13](#) [DMN2990UFB-7B](#)  
[IPB80P04P405ATMA2](#) [2N7002W-G](#) [MCAC30N06Y-TP](#) [MCQ7328-TP](#) [BXP7N65D](#) [BXP4N65F](#) [AOL1454G](#) [WMJ80N60C4](#) [BXP2N20L](#)  
[BXP2N65D](#) [BXT1150N10J](#) [BXT1700P06M](#) [TSM60NB380CP](#) [ROG](#) [RQ7L055BGTCR](#) [DMNH15H110SK3-13](#) [SLF10N65ABV2](#)  
[BSO203SP](#) [BSO211P](#) [IPA60R230P6](#) [IPA60R460CE](#)