



## WGF2N65SE

### Features:

- Low Intrinsic Capacitances.
- Excellent Switching Characteristics.
- Extended Safe Operating Area.
- Unrivalled Gate Charge : $Q_g=6.7nC$  (Typ.).
- $BVDSS=650V, I_D=2A$
- $R_{DS(on)} : 4.5\Omega$  (Typ) @  $V_G=10V$
- 100% Avalanche Tested

TO-220F

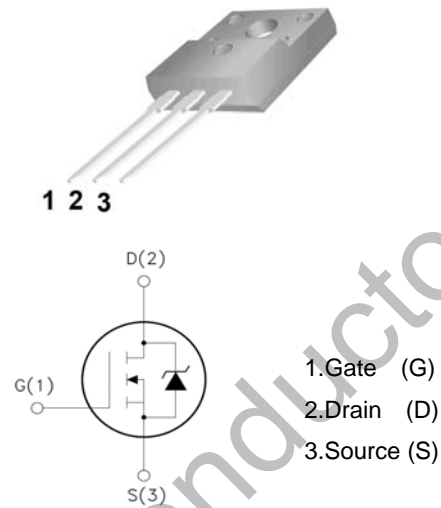

### Absolute Maximum Ratings ( $T_a=25^\circ C$ unless otherwise noted)

| Symbol    | Parameter  | Value             | Unit       |
|-----------|--|-------------------|------------|
| $V_{DSS}$ | Drain-Source Voltage   | 650               | V          |
| $I_D$     | Drain Current  | $T_j=25^\circ C$  | 2.0        |
|           |  | $T_j=100^\circ C$ | 1.25       |
| $V_{GSS}$ | Gate - Source voltage  | $\pm 30$          | V          |
| $E_{AS}$  | Single Pulse Avalanche Energy (note1)  | 120               | mJ         |
| $I_{AR}$  | Avalanche Current (note2)  | 2                 | A          |
| $P_D$     | Power Dissipation ( $T_j=25^\circ C$ )                                       | 28                | W          |
| $T_j$     | Junction Temperature(Max)  | 150               | $^\circ C$ |
| $T_{stg}$ | Storage Temperature  | -55~+150          | $^\circ C$ |
| TL        | Maximum lead temperature for soldering purpose, 1/8" from case for 5 seconds | 300               | $^\circ C$ |

### Thermal Characteristics

| Symbol          | Parameter                               | Typ. | Max. | Unit         |
|-----------------|---|------|------|--------------|
| $R_{\theta JC}$ | Thermal Resistance, Junction to Case    | -    | 4.46 | $^\circ C/W$ |
| $R_{\theta JA}$ | Thermal Resistance, Junction to Ambient | -    | 62.5 | $^\circ C/W$ |

**Electrical Characteristics** (Ta=25°C unless otherwise noted)

| Symbol  | Parameter                                 | Test Condition  | Min. | Typ. | Max. | Unit |
|---|---|---|------|------|------|------|
| <b>Off Characteristics</b>                                    |   |   |      |      |      |      |
| BV <sub>DSS</sub>   | Drain-Source Breakdown Voltage            | I <sub>D</sub> =250μA, V <sub>GS</sub> =0                                   | 650  | -    | -    | V    |
| ΔBV <sub>DSS</sub> /ΔT <sub>J</sub>                           | Breakdown Voltage Temperature Coefficient | I <sub>D</sub> =250μA, Reference to 25°C                                    | -    | 0.6  | -    | V/°C |
| I <sub>DSS</sub>  | Zero Gate Voltage Drain Current           | V <sub>DS</sub> =650V, V <sub>GS</sub> =0V                                  | -    | -    | 1    | μA   |
|   |   | V <sub>DS</sub> =520V, T <sub>J</sub> =125°C                                | -    | -    | 10   |      |
| I <sub>GSSF</sub>   | Gate-body leakage Current, Forward        | V <sub>GS</sub> =+30V, V <sub>DS</sub> =0V                                  | -    | -    | 100  | nA   |
| I <sub>GSSR</sub>   | Gate-body leakage Current, Reverse        | V <sub>GS</sub> =-30V, V <sub>DS</sub> =0V                                  | -    | -    | -100 |      |
| <b>On Characteristics</b>                                     |   |   |      |      |      |      |
| V <sub>GS(TH)</sub>   | Date Threshold Voltage                    | I <sub>D</sub> =250μA, V <sub>DS</sub> =V <sub>GS</sub>                     | 2    | -    | 4    | V    |
| R <sub>DS(ON)</sub>   | Static Drain-Source On-Resistance         | I <sub>D</sub> =1A, V <sub>GS</sub> =10V                                    | -    | 4.5  | 4.8  | Ω    |
| <b>Dynamic Characteristics</b>                                |   |   |      |      |      |      |
| C <sub>iss</sub>  | Input Capacitance                         | V <sub>DS</sub> =25V, V <sub>GS</sub> =0, f=1.0MHz                          | -    | 320  | -    | pF   |
| C <sub>oss</sub>  | Output Capacitance                        |   | -    | 40   | -    |      |
| C <sub>rss</sub>  | Reverse Transfer Capacitance              |   | -    | 5    | -    |      |
| <b>Switching Characteristics</b>                              |   |   |      |      |      |      |
| T <sub>d(on)</sub>  | Turn-On Delay Time                        | V <sub>DD</sub> =325V, I <sub>D</sub> =2A<br>R <sub>G</sub> =25Ω (Note 3,4) | -    | 10   | -    | ns   |
| T <sub>r</sub>  | Turn-On Rise Time                         |   | -    | 25   | -    |      |
| T <sub>d(off)</sub>   | Turn-Off Delay Time                       |   | -    | 20   | -    |      |
| T <sub>f</sub>  | Turn-Off Rise Time                        |   | -    | 24   | -    |      |
| Q <sub>g</sub>  | Total Gate Charge                         | V <sub>DS</sub> =520V, V <sub>GS</sub> =10V, I <sub>D</sub> =2A (Note 3,4)  | -    | 6.7  | -    | nC   |
| Q <sub>gs</sub>   | Gate-Source Charge                        |   | -    | 1.9  | -    |      |
| Q <sub>gd</sub>   | Gate-Drain Charge                         |   | -    | 1.8  | -    |      |
| <b>Drain-Source Diode Characteristics and Maximum Ratings</b> |   |   |      |      |      |      |
| I <sub>S</sub>  | Max. Diode Forward Current                | -   | -    | -    | 2    | A    |
| I <sub>SM</sub>   | Max. Pulsed Forward Current               | -   | -    | -    | 8    |      |
| V <sub>SD</sub>   | Diode Forward Voltage                     | I <sub>D</sub> =2A  | -    | -    | 1.5  | V    |
| T <sub>rr</sub>   | Reverse Recovery Time                     | I <sub>S</sub> =2A, V <sub>GS</sub> =0V<br>diF/dt=100A/μs                   | -    | 368  | -    | nS   |
| Q <sub>rr</sub>   | Reverse Recovery Charge                   | (Note3)   | -    | 1.0  | -    | μC   |

Notes : 1, L=55mH, I<sub>AS</sub>=2A, V<sub>DD</sub>=50V, R<sub>G</sub>=25Ω, Starting T<sub>J</sub>=25°C

2, Repetitive Rating : Pulse width limited by maximum junction temperature

3, Pulse Test : Pulse Width ≤ 300μs, Duty Cycle ≤ 2%

4, Essentially Independent of Operating Temperature

Typical Characteristics

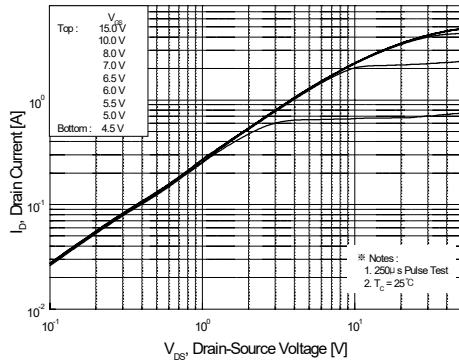

Figure 1. On-Region Characteristics

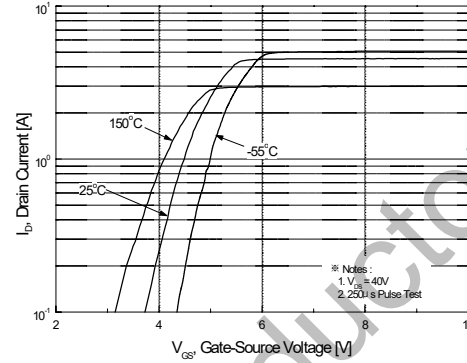

Figure 2. Transfer Characteristics

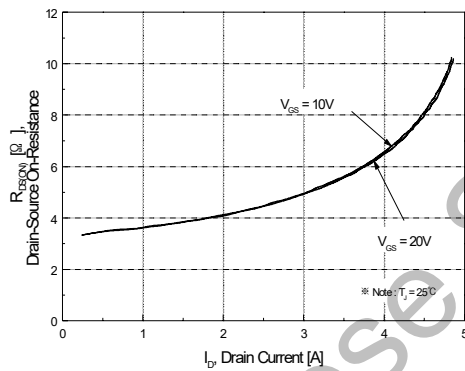

Figure 3. On-Resistance Variation vs Drain Current and Gate Voltage

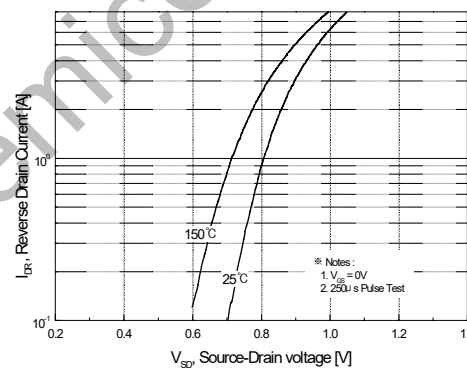

Figure 4. Body Diode Forward Voltage Variation with Source Current and Temperature

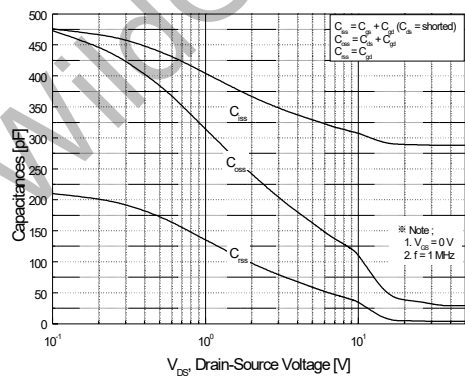

Figure 5. Capacitance Characteristics

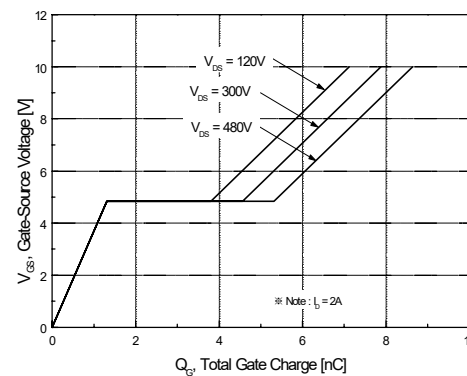

Figure 6. Gate Charge Characteristics

Typical Characteristics (Continued)

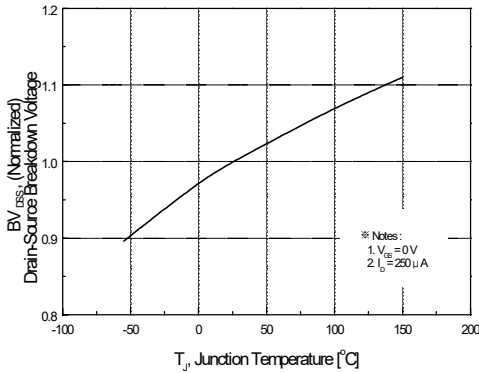

Figure 7. Breakdown Voltage Variation vs Temperature

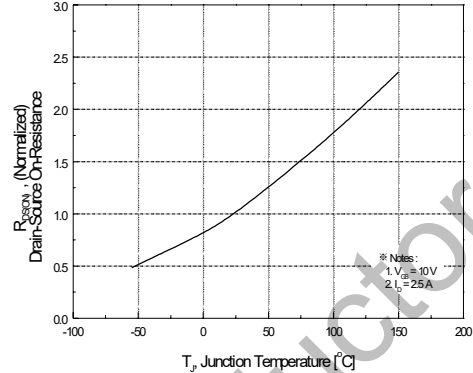

Figure 8. On-Resistance Variation vs Temperature

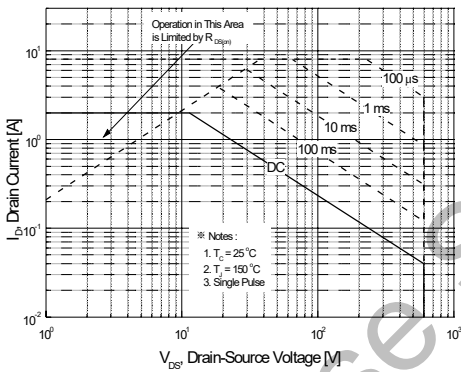

Figure 9-2. Maximum Safe Operating Area

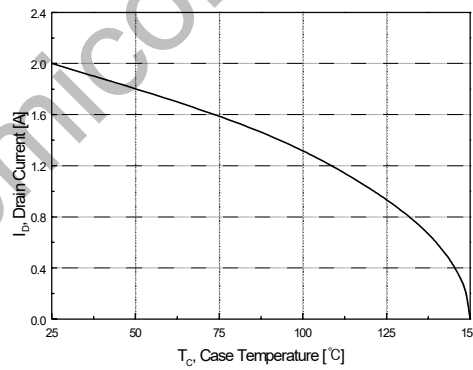

Figure 10. Maximum Drain Current vs Case Temperature

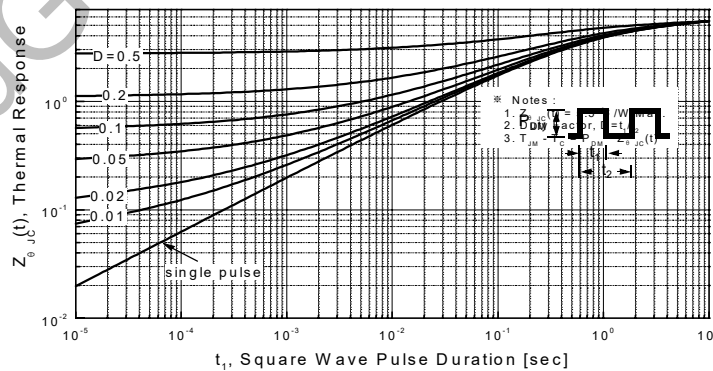
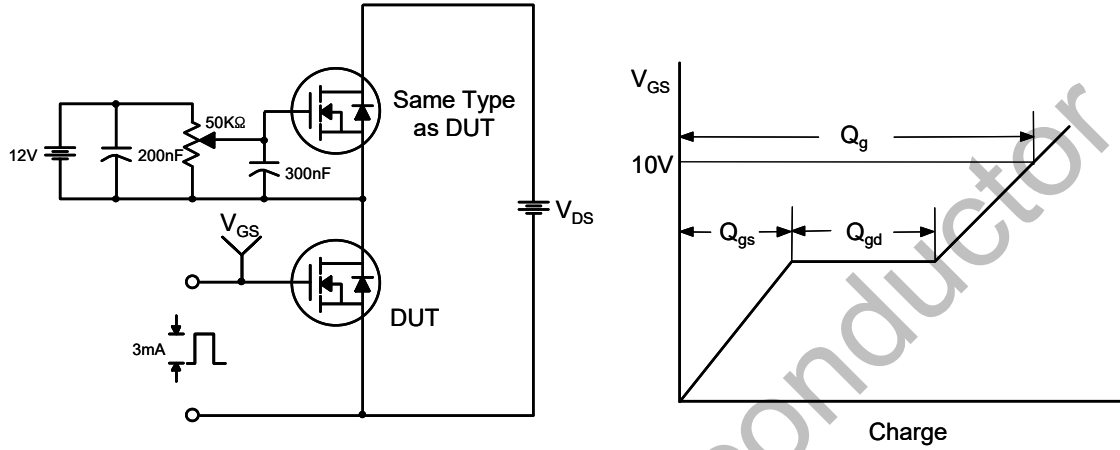
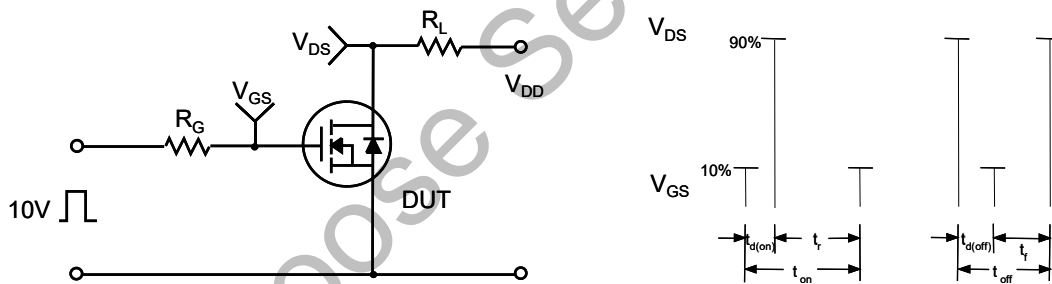

Figure 11-2. Transient Thermal Response Curve

### Gate Charge Test Circuit & Waveform



### Resistive Switching Test Circuit & Waveforms



### Unclamped Inductive Switching Test Circuit & Waveforms

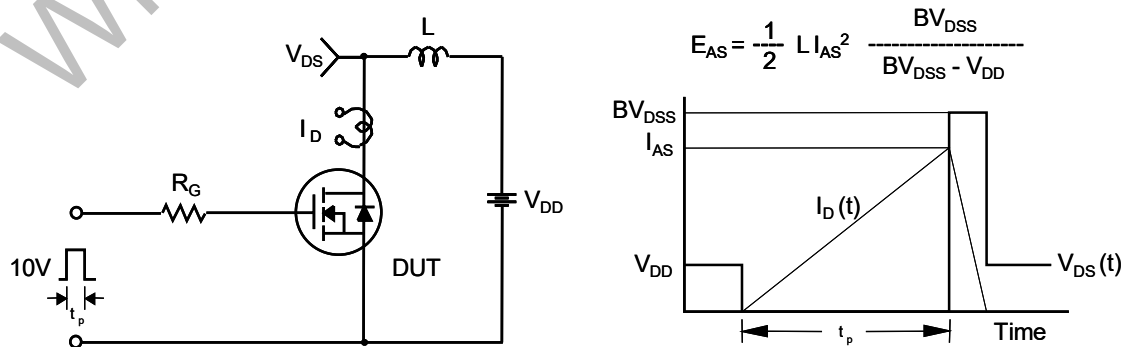

Peak Diode Recovery dv/dt Test Circuit & Waveforms

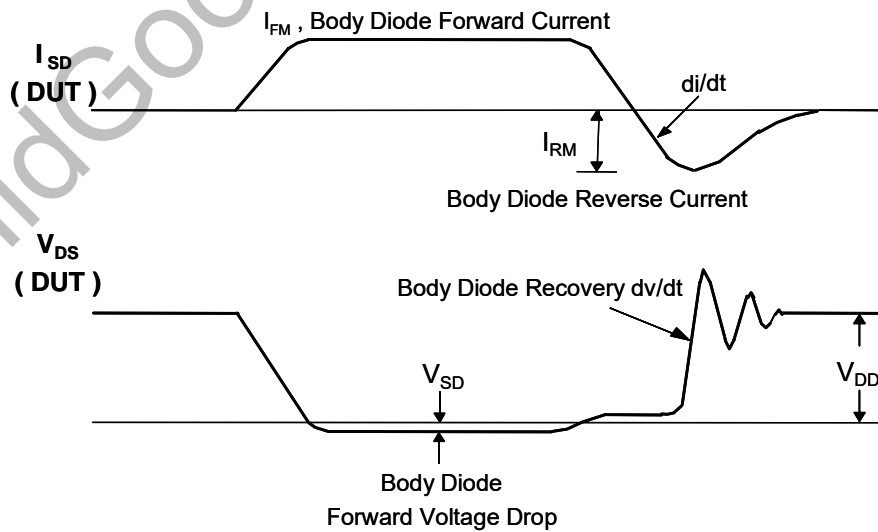
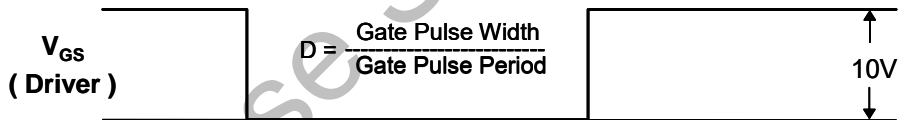
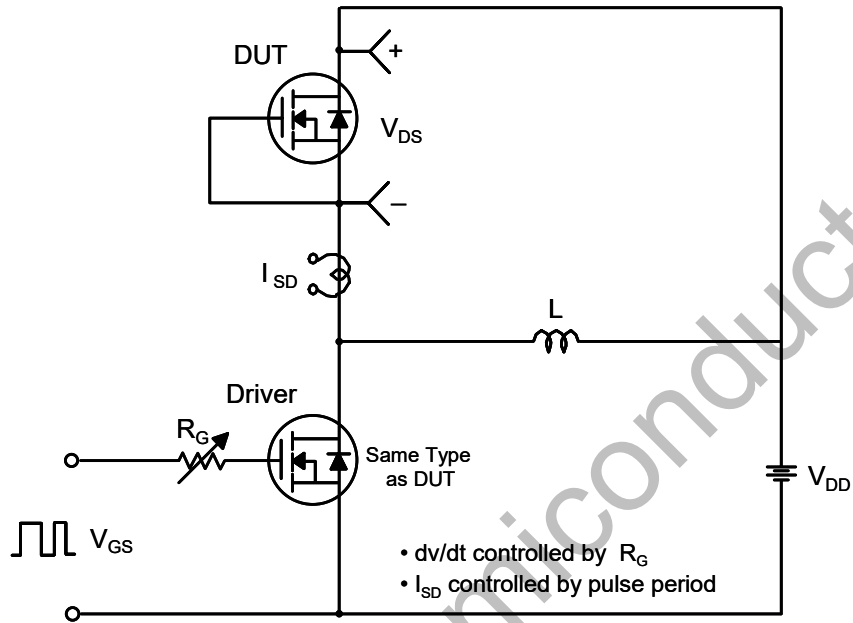

**Package Dimension**

TO-220F

Unit: mm

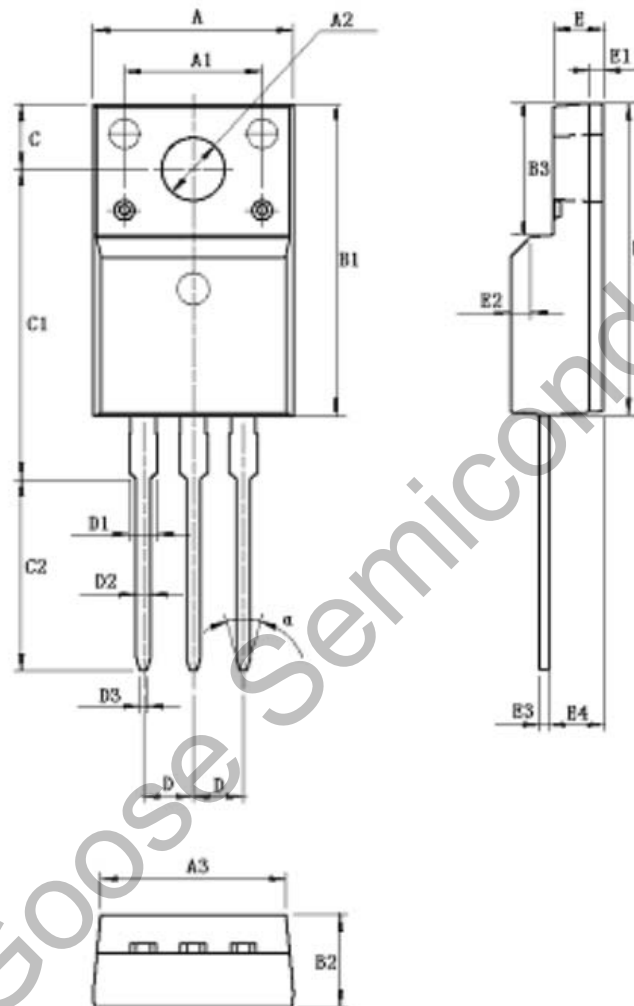

| Symbol | Min   | Max   | Symbol    | Min     | Max  |
|--------|-------|-------|-----------|---------|------|
| A      | 9.96  | 10.36 | D         | 2.54    |      |
| A1     | 7.00  |       | D1        | 1.15    | 1.35 |
| A2     | 3.08  | 3.28  | D2        | 0.70    | 0.90 |
| A3     | 9.25  | 9.65  | D3        | 0.28    | 0.48 |
| B1     | 15.70 | 16.10 | E         | 2.34    | 2.74 |
| B2     | 4.50  | 4.90  | E1        | 0.70    |      |
| B3     | 6.20  | 6.80  | E2        | 1.0×45° |      |
| C      | 3.20  | 3.40  | E3        | 0.36    | 0.65 |
| C1     | 15.20 | 16.00 | E4        | 2.55    | 2.95 |
| C2     | 9.75  | 10.15 | a (angle) | 30°     |      |

## X-ON Electronics

Largest Supplier of Electrical and Electronic Components

*Click to view similar products for [MOSFET](#) category:*

*Click to view products by [Wild Goose](#) manufacturer:*

Other Similar products are found below :

[IRFD120](#) [JANTX2N5237](#) [BUK455-60A/B](#) [MIC4420CM-TR](#) [VN1206L](#) [NDP4060](#) [SI4482DY](#) [IPS70R2K0CEAKMA1](#) [SQD23N06-31L-GE3](#)  
[TK16J60W,S1VQ\(O](#) [2SK2614\(TE16L1,Q\)](#) [DMN1017UCP3-7](#) [DMN1053UCP4-7](#) [SQJ469EP-T1-GE3](#) [NTE2384](#) [DMC2700UDMQ-7](#)  
[DMN2080UCB4-7](#) [DMN61D9UWQ-13](#) [US6M2GTR](#) [DMN31D5UDJ-7](#) [DMP22D4UFO-7B](#) [DMN1006UCA6-7](#) [DMN16M9UCA6-7](#)  
[STF5N65M6](#) [IRF40H233XTMA1](#) [STU5N65M6](#) [DMN6022SSD-13](#) [DMN13M9UCA6-7](#) [DMTH10H4M6SPS-13](#) [DMN2990UFB-7B](#)  
[IPB80P04P405ATMA2](#) [2N7002W-G](#) [MCAC30N06Y-TP](#) [MCQ7328-TP](#) [BXP7N65D](#) [BXP4N65F](#) [AOL1454G](#) [WMJ80N60C4](#) [BXP2N20L](#)  
[BXP2N65D](#) [BXT1150N10J](#) [BXT1700P06M](#) [TSM60NB380CP](#) [ROG](#) [RQ7L055BGTCR](#) [DMNH15H110SK3-13](#) [SLF10N65ABV2](#)  
[BSO203SP](#) [BSO211P](#) [IPA60R230P6](#) [IPA60R460CE](#)