



WGP10N65SE

Features:

- Low Intrinsic Capacitances.
- Excellent Switching Characteristics.
- Extended Safe Operating Area.
- Unrivalled Gate Charge : $Q_g=35\text{nC}$ (Typ.).
- $BV_{DSS}=650\text{ V}$, $I_D=10\text{ A}$
- $R_{DS(on)} : 0.9\ \Omega$ (Max) @ $V_G=10\text{ V}$
- 100% Avalanche Tested

TO-220

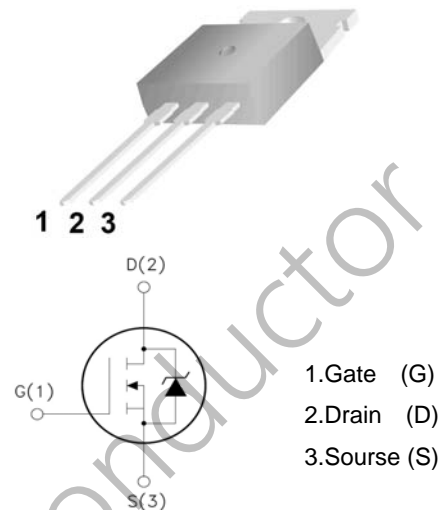

Absolute Maximum Ratings (Ta=25°C unless otherwise noted)

Symbol	Parameter	Value	Unit
V_{DSS}	Drain-Source Voltage	650	V
I_D	Drain Current	$T_j=25^\circ\text{C}$	10
		$T_j=100^\circ\text{C}$	6.7
$V_{GS(TH)}$	Gate Threshold Voltage	30	V
E_{AS}	Single Pulse Avalanche Energy (note1)	380	mJ
I_{AR}	Avalanche Current (note2)	10	A
P_D	Power Dissipation ($T_j=25^\circ\text{C}$)	65	W
T_j	Junction Temperature(Max)	150	$^\circ\text{C}$
T_{stg}	Storage Temperature	-55~+150	$^\circ\text{C}$
TL	Maximum lead temperature for soldering purpose, 1/8' from case for 5 seconds	300	$^\circ\text{C}$

Thermal Characteristics

Symbol	Parameter	Typ.	Max.	Unit
$R_{\theta JC}$	Thermal Resistance, Junction to Case	-	2.4	$^\circ\text{C}/\text{W}$
$R_{\theta JA}$	Thermal Resistance, Junction to Ambient	-	62.5	$^\circ\text{C}/\text{W}$

Electrical Characteristics (Ta=25°C unless otherwise noted)

Symbol	Parameter	Test Condition	Min.	Typ.	Max.	Unit
Off Characteristics						
BV_{DSS}	Drain-Source Breakdown Voltage	$I_D=250\mu A, V_{GS}=0$	650	-	-	V
$\Delta BV_{DSS}/\Delta T_J$	Breakdown Voltage Temperature Coefficient	$I_D=250\mu A$, Reference to 25°C	-	0.67	-	V/°C
I_{DSS}	Zero Gate Voltage Drain Current	$V_{DS}=650V, V_{GS}=0V$	-	-	10	μA
		$V_{DS}=520V, T_J=125^\circ C$			100	
I_{GSSF}	Gate-body leakage Current, Forward	$V_{GS}=+30V, V_{DS}=0V$	-	-	100	nA
I_{GSSR}	Gate-body leakage Current, Reverse	$V_{GS}=-30V, V_{DS}=0V$	-	-	-100	
On Characteristics						
$V_{GS(TH)}$	Gate Threshold Voltage	$I_D=250\mu A, V_{DS}=V_{GS}$	2	-	4	V
$R_{DS(ON)}$	Static Drain-Source On-Resistance	$I_D=5.0A, V_{GS}=10V$	-	0.8	0.9	Ω
Dynamic Characteristics						
C_{iss}	Input Capacitance	$V_{DS}=25V, V_{GS}=0, f=1.0MHz$	-	1500	-	pF
C_{oss}	Output Capacitance		-	194	-	
C_{rss}	Reverse Transfer Capacitance		-	18	-	
Switching Characteristics						
$T_d(on)$	Turn-On Delay Time	$V_{DD}=325V, I_D=10A, R_G=25\Omega$ (Note 3,4)	-	23		nS
T_r	Turn-On Rise Time			15		
$T_d(off)$	Turn-Off Delay Time			90		
T_f	Turn-Off Rise Time			30		
Q_g	Total Gate Charge	$V_{DS}=520V, V_{GS}=10V, I_D=10A$ (Note3,4)	-	35		nC
Q_{gs}	Gate-Source Charge			7	-	
Q_{gd}	Gate-Drain Charge			18	-	
Drain-Source Diode Characteristics and Maximum Ratings						
I_S	Max. Diode Forward Current	-		-	10	A
I_{SM}	Max. Pulsed Forward Current	-		-	40	
V_{SD}	Diode Forward Voltage	$I_D=10A$	-	-	1.4	V
T_{rr}	Reverse Recovery Time	$I_S=10A, V_{GS}=0V, diF/dt=100A/\mu s$ (Note3)	-	320	-	nS
Q_{rr}	Reverse Recovery Charge		-	4.2	-	μC

- Notes : 1, L=0.5mH, IAS= 10A, VDD=50V, RG=25 Ω , Starting T_J =25°C
 2, Repetitive Rating : Pulse width limited by maximum junction temperature
 3, Pulse Test : Pulse Width $\leq 300\mu s$, Duty Cycle $\leq 2\%$
 4, Essentially Independent of Operating Temperature

Typical Characteristics

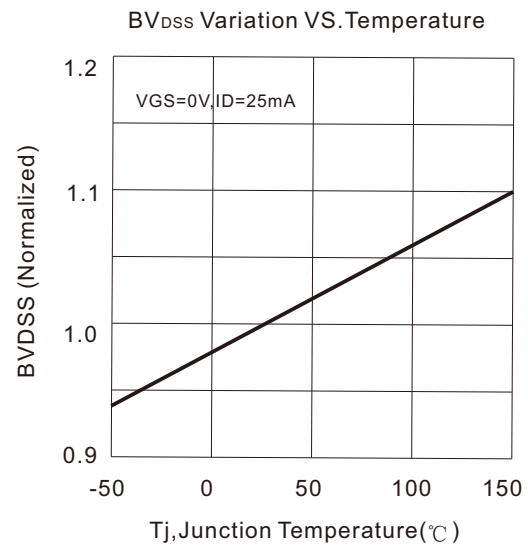
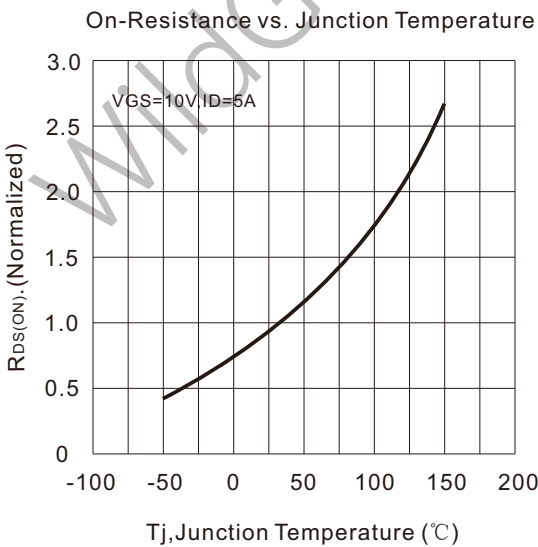
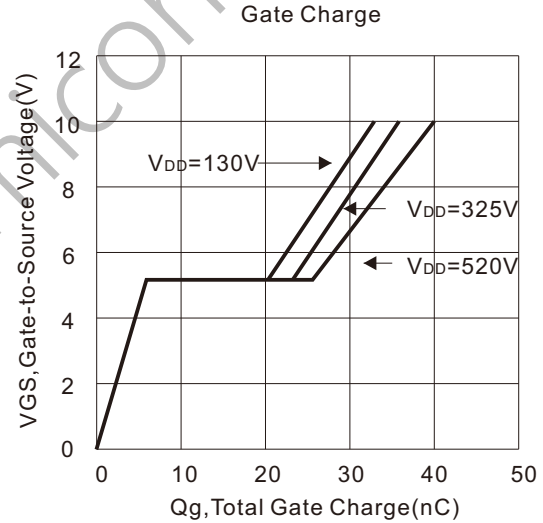
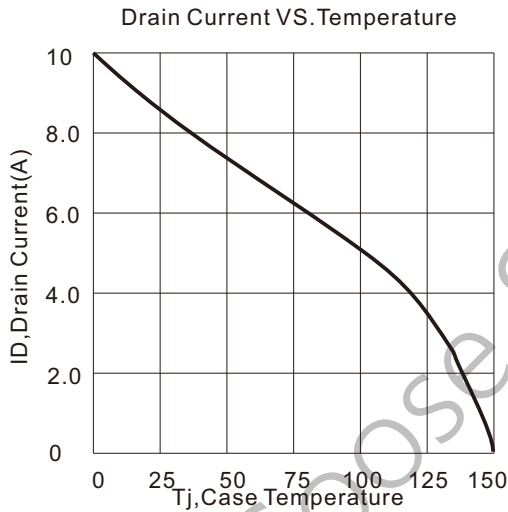
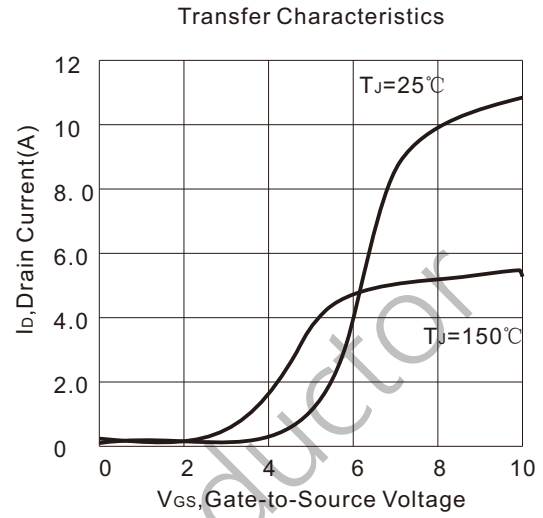
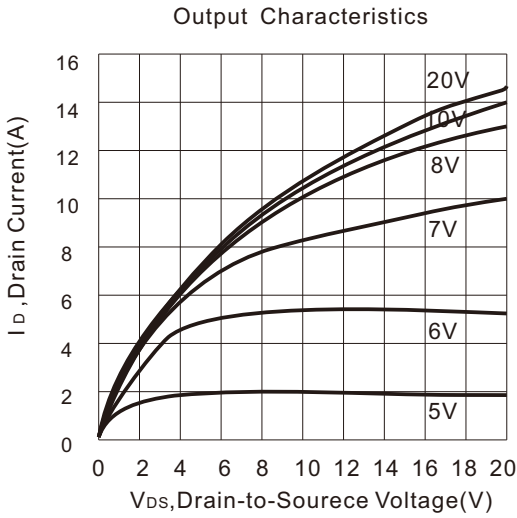

Typical Characteristics (Continued)

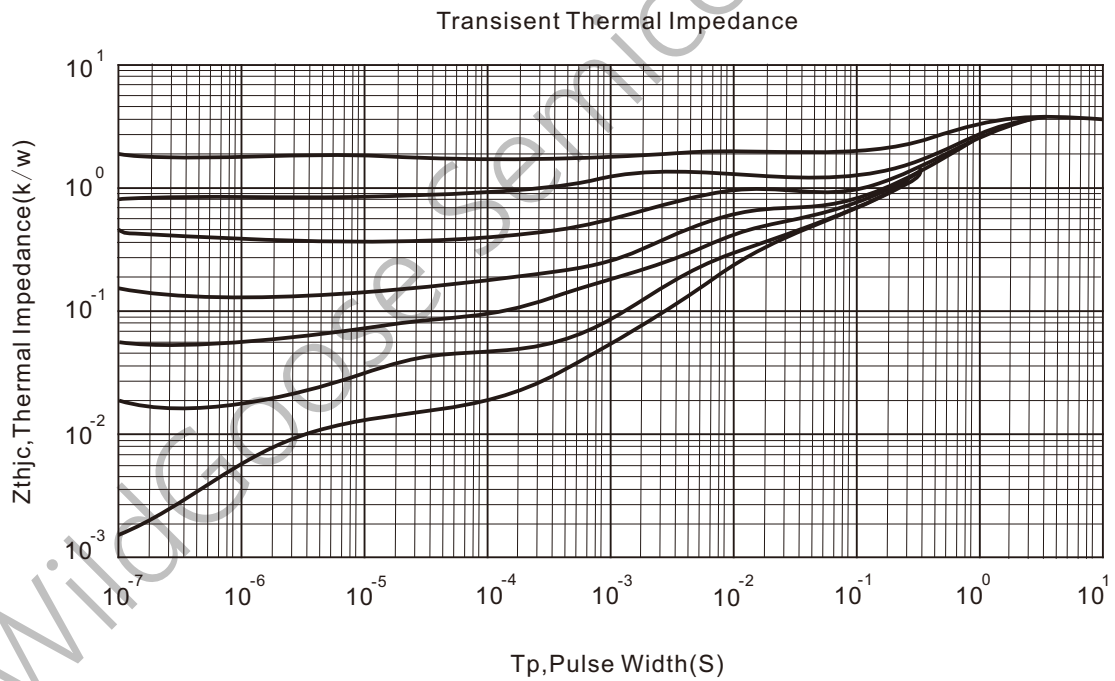
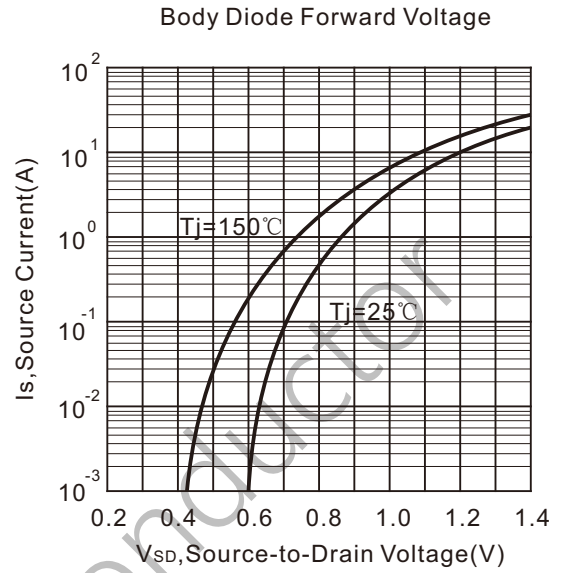
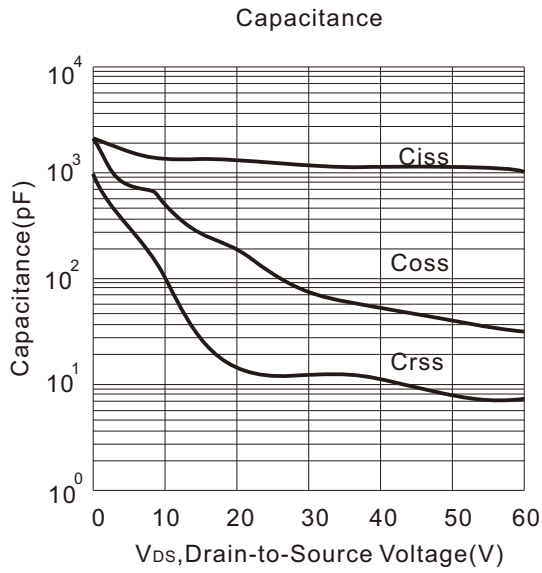

Gate Charge Test Circuit & Waveform

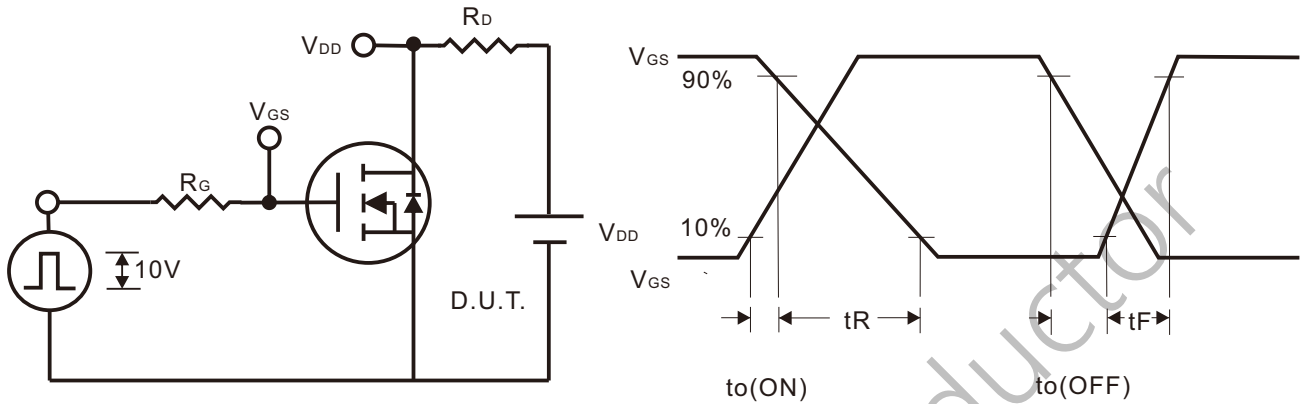

Switching Test Circuit

Switching Waveforms

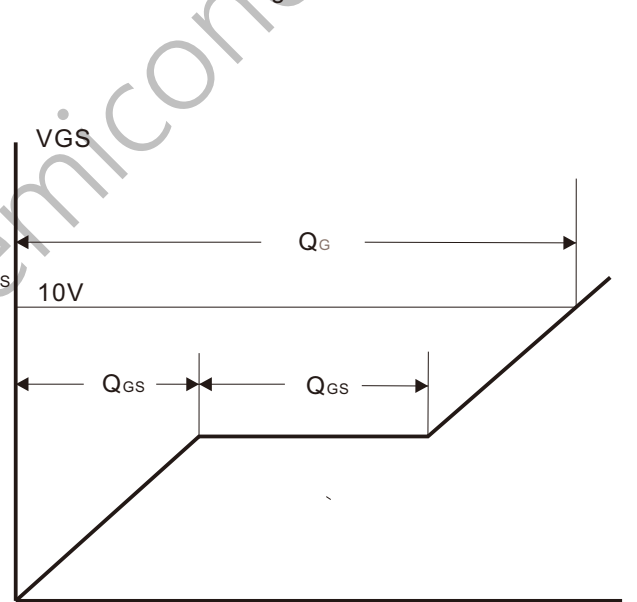
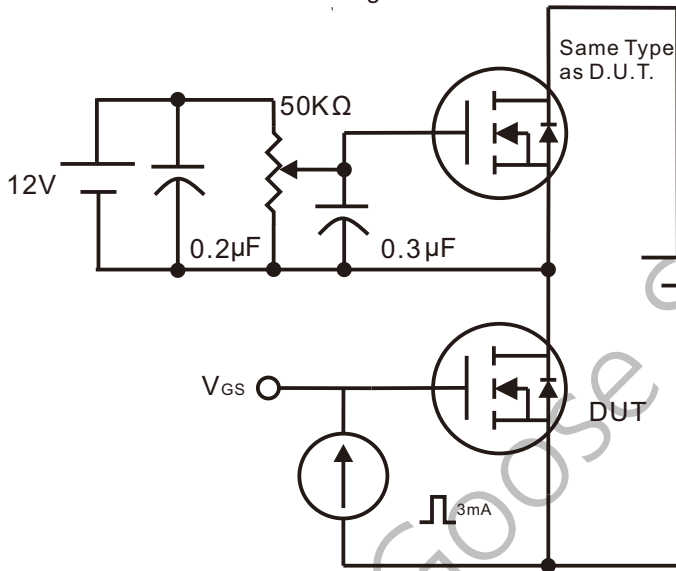

Gate Charge Test Circuit

Gate Charge Waveform

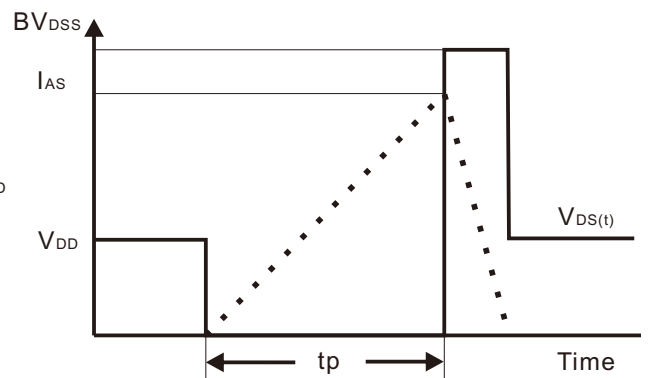
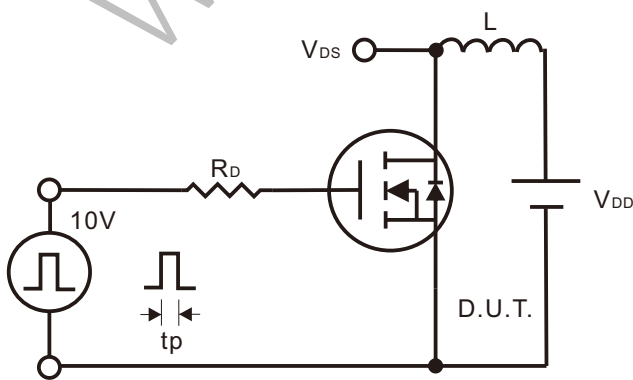

Unclamped Inductive Switching Test Circuit

Unclamped Inductive Switching Waveforms

Peak Diode Recovery dv/dt Test Circuit & Waveform

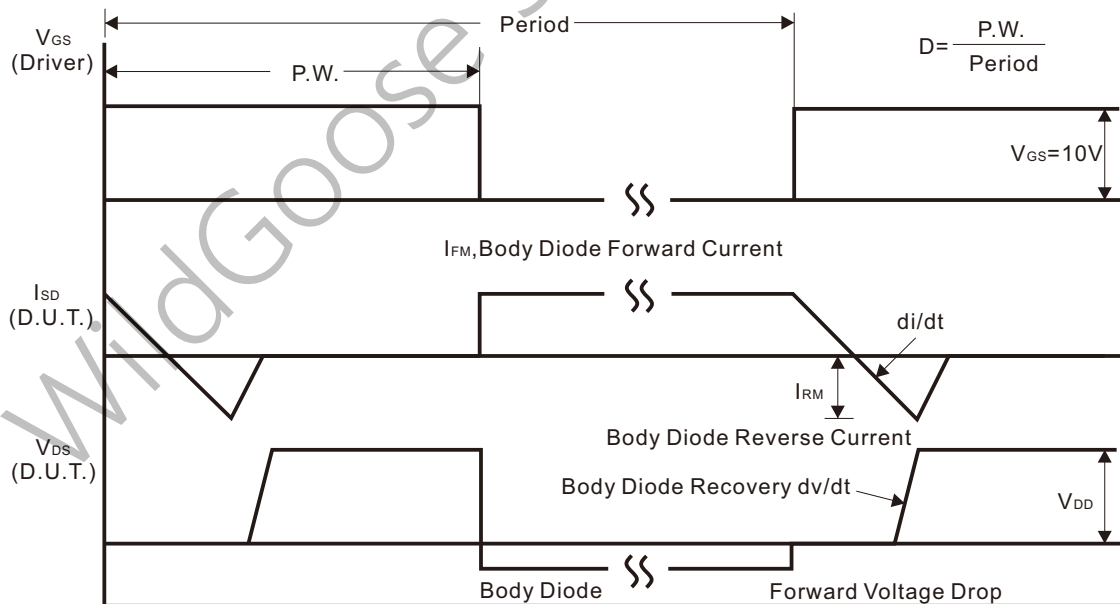
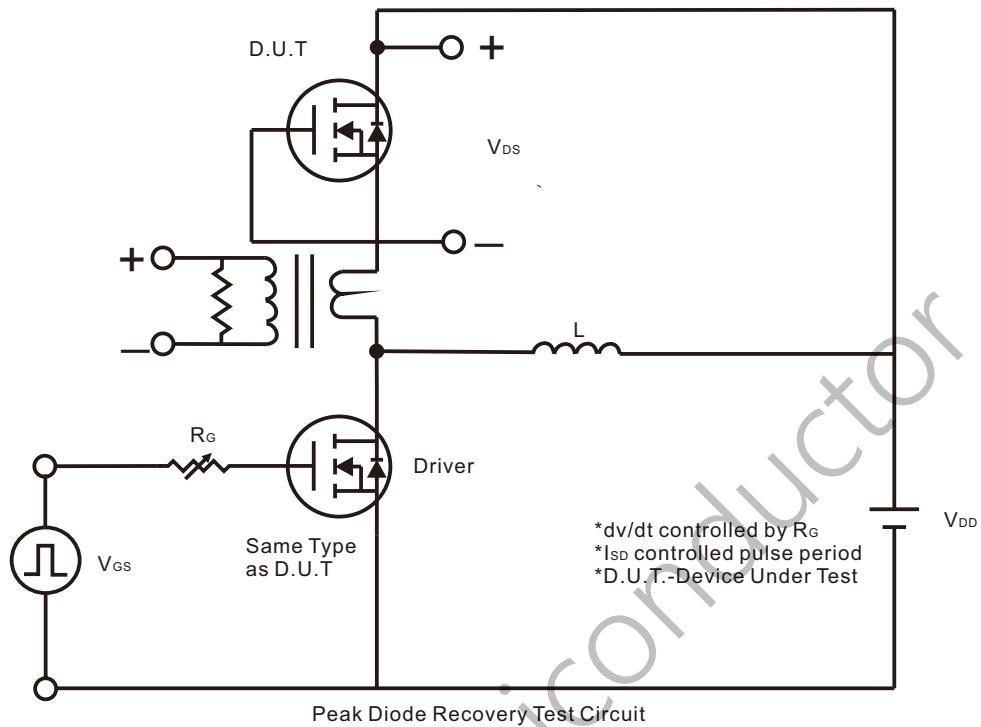

Package Dimension

TO-220

Unit:mm

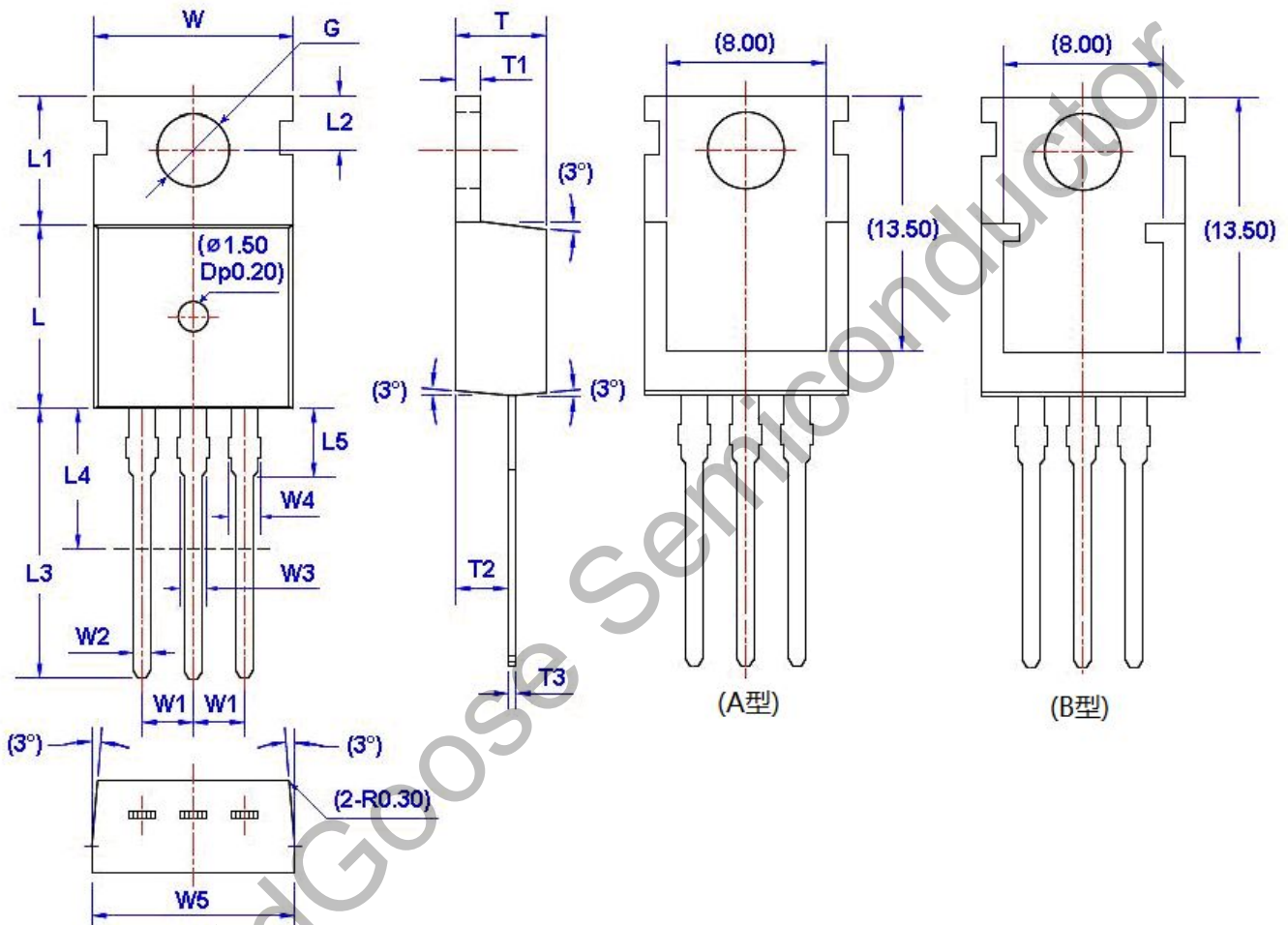

符号	尺寸		符号	尺寸		符号	尺寸		符号	尺寸	
	Min	Max		Min	Max		Min	Max		Min	Max
W	9.66	10.28	W5	9.80	10.20	L4**	6.20	6.60	T3	0.45	0.60
W1	2.54 (TYP)		L	9.00	9.40	L5	2.79	3.30	G(Φ)	3.50	3.70
W2	0.70	0.95	L1	6.40	6.80	T	4.30	4.70			
W3	1.17	1.37	L2	2.70	2.90	T1	1.15	1.40			
W4*	1.32	1.72	L3	12.70	14.27	T2	2.20	2.60			

X-ON Electronics

Largest Supplier of Electrical and Electronic Components

Click to view similar products for [MOSFET](#) category:

Click to view products by [Wild Goose](#) manufacturer:

Other Similar products are found below :

[IRFD120](#) [JANTX2N5237](#) [BUK455-60A/B](#) [MIC4420CM-TR](#) [VN1206L](#) [NDP4060](#) [SI4482DY](#) [IPS70R2K0CEAKMA1](#) [SQD23N06-31L-GE3](#)
[TK16J60W,S1VQ\(O](#) [2SK2614\(TE16L1,Q\)](#) [DMN1017UCP3-7](#) [DMN1053UCP4-7](#) [SQJ469EP-T1-GE3](#) [NTE2384](#) [DMC2700UDMQ-7](#)
[DMN2080UCB4-7](#) [DMN61D9UWQ-13](#) [US6M2GTR](#) [DMN31D5UDJ-7](#) [DMP22D4UFO-7B](#) [DMN1006UCA6-7](#) [DMN16M9UCA6-7](#)
[STF5N65M6](#) [IRF40H233XTMA1](#) [STU5N65M6](#) [DMN6022SSD-13](#) [DMN13M9UCA6-7](#) [DMTH10H4M6SPS-13](#) [DMN2990UFB-7B](#)
[IPB80P04P405ATMA2](#) [2N7002W-G](#) [MCAC30N06Y-TP](#) [MCQ7328-TP](#) [BXP7N65D](#) [BXP4N65F](#) [AOL1454G](#) [WMJ80N60C4](#) [BXP2N20L](#)
[BXP2N65D](#) [BXT1150N10J](#) [BXT1700P06M](#) [TSM60NB380CP ROG](#) [RQ7L055BGTCR](#) [DMNH15H110SK3-13](#) [SLF10N65ABV2](#)
[BSO203SP](#) [BSO211P](#) [IPA60R230P6](#) [IPA60R460CE](#)