



## WGP7N70SE

## Features:

- Low Intrinsic Capacitances.
- Excellent Switching Characteristics.
- Extended Safe Operating Area.
- Unrivalled Gate Charge : $Q_g=30nC$  (Typ.).
- $BVDSS=700V, I_D=7A$
- $R_{DS(on)} : 1.5\Omega$  (Max) @  $V_G=10V$
- 100% Avalanche Tested

TO-220

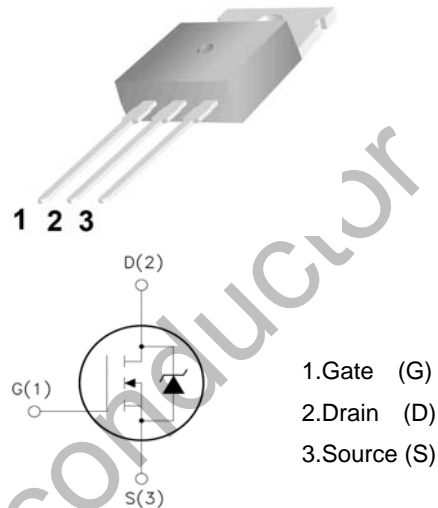

- 1.Gate (G)
- 2.Drain (D)
- 3.Source (S)

**Absolute Maximum Ratings** ( $T_a=25^\circ C$  unless otherwise noted)

Symbol	Parameter	Value	Unit
$V_{DSS}$	Drain-Source Voltage	700	V
$I_D$	Drain Current	$T_j=25^\circ C$	7
		$T_j=100^\circ C$	3.9
$V_{GS(TH)}$	Gate Threshold Voltage	$\pm 30$	V
$E_{AS}$	Single Pulse Avalanche Energy (note1)	300	mJ
$I_{AR}$	Avalanche Current (note2)	7	A
$P_D$	Power Dissipation ( $T_j=25^\circ C$ )	40	W
$T_j$	Junction Temperature(Max)	150	$^\circ C$
$T_{stg}$	Storage Temperature	-55~+150	$^\circ C$
TL	Maximum lead temperature for soldering purpose, 1/8" from case for 5 seconds	300	$^\circ C$

**Thermal Characteristics**

Symbol	Parameter	Typ.	Max.	Unit
$R_{\theta JC}$	Thermal Resistance, Junction to Case	-	3.2	$^\circ C/W$
$R_{\theta JA}$	Thermal Resistance, Junction to Ambient	-	62.5	$^\circ C/W$

**Electrical Characteristics** (Ta=25°C unless otherwise noted)

Symbol	Parameter	Test Condition	Min.	Typ.	Max.	Unit
<b>Off Characteristics</b>						
BV <sub>DSS</sub>	Drain-Source Breakdown Voltage	I <sub>D</sub> =250μA, V <sub>GS</sub> =0	700	-	-	V
ΔBV <sub>DSS</sub> /ΔT <sub>J</sub>	Breakdown Voltage Temperature Coefficient	I <sub>D</sub> =250μA, Reference to 25°C	-	0.6	-	V/°C
I <sub>DSS</sub>	Zero Gate Voltage Drain Current	V <sub>DS</sub> =700V, V <sub>GS</sub> =0V	-	-	1	μA
		V <sub>DS</sub> =560V, T <sub>J</sub> =125°C	-	-	10	
I <sub>GSSF</sub>	Gate-body leakage Current, Forward	V <sub>GS</sub> =+30V, V <sub>DS</sub> =0V	-	-	100	nA
I <sub>GSSR</sub>	Gate-body leakage Current, Reverse	V <sub>GS</sub> =-30V, V <sub>DS</sub> =0V	-	-	-100	
<b>On Characteristics</b>						
V <sub>GS(TH)</sub>	Gate Threshold Voltage	I <sub>D</sub> =250μA, V <sub>DS</sub> =V <sub>GS</sub>	3	-	4	V
R <sub>DS(ON)</sub>	Static Drain-Source On-Resistance	I <sub>D</sub> =3A, V <sub>GS</sub> =10V	-	-	1.5	Ω
<b>Dynamic Characteristics</b>						
C <sub>iss</sub>	Input Capacitance	V <sub>DS</sub> =25V, V <sub>GS</sub> =0, f=1.0MHz	-	1100	-	pF
C <sub>oss</sub>	Output Capacitance		-	125	-	
C <sub>rss</sub>	Reverse Transfer Capacitance		-	15	-	
<b>Switching Characteristics</b>						
T <sub>d(on)</sub>	Turn-On Delay Time	V <sub>DD</sub> =350V, I <sub>D</sub> =6A R <sub>G</sub> =25Ω (Note 3,4)	-	13	35	ns
T <sub>r</sub>	Turn-On Rise Time		-	45	100	
T <sub>d(off)</sub>	Turn-Off Delay Time		-	25	60	
T <sub>f</sub>	Turn-Off Rise Time		-	35	80	
Q <sub>g</sub>	Total Gate Charge	V <sub>DS</sub> =560V, V <sub>GS</sub> =10V, I <sub>D</sub> =6A (Note 3,4)	-	30	40	nC
Q <sub>gs</sub>	Gate-Source Charge		-	3.5	-	
Q <sub>gd</sub>	Gate-Drain Charge		-	6.5	-	
<b>Drain-Source Diode Characteristics and Maximum Ratings</b>						
I <sub>S</sub>	Max. Diode Forward Current	-	-	-	7	A
I <sub>SM</sub>	Max. Pulsed Forward Current	-	-	-	24	
V <sub>SD</sub>	Diode Forward Voltage	I <sub>D</sub> =7A	-	-	1.25	V
T <sub>rr</sub>	Reverse Recovery Time	I <sub>S</sub> =7A, V <sub>GS</sub> =0V diF/dt=100A/μs	-	310	-	nS
Q <sub>rr</sub>	Reverse Recovery Charge	(Note3)	-	2.1	-	μC

Notes : 1, L=27.5mH, I<sub>AS</sub>=7A, V<sub>DD</sub>=50V, R<sub>G</sub>=25Ω, Starting T<sub>J</sub>=25°C

2, Repetitive Rating : Pulse width limited by maximum junction temperature

3, Pulse Test : Pulse Width ≤ 300μs, Duty Cycle ≤ 2%

4, Essentially Independent of Operating Temperature

Typical Characteristics

Figure 1. On-Region Characteristics

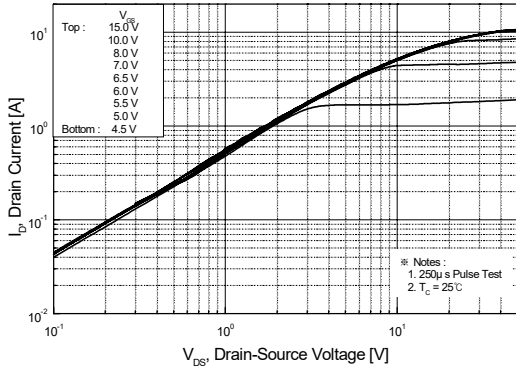

Figure 2. Transfer Characteristics

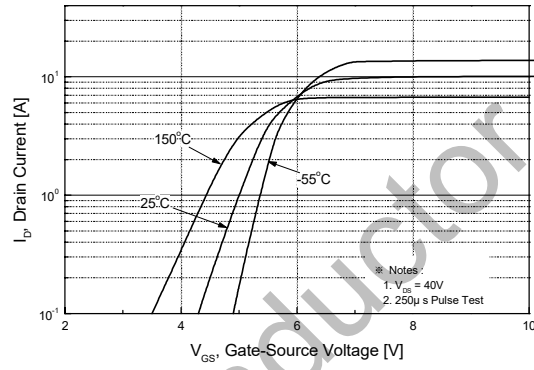

Figure 3. On-Resistance Variation vs. Drain Current and Gate Voltage

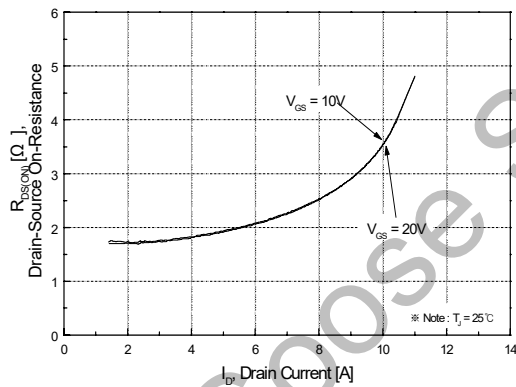

Figure 4. Body Diode Forward Voltage Variation vs. Source Current and Temperature

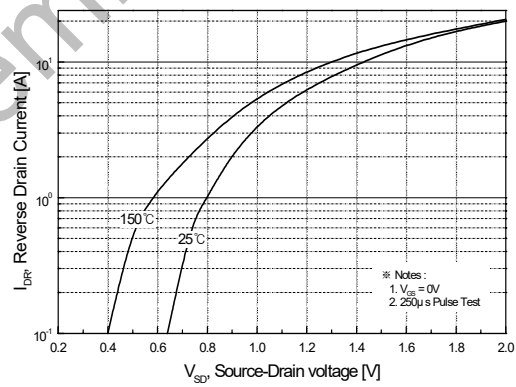

Figure 5. Capacitance Characteristics

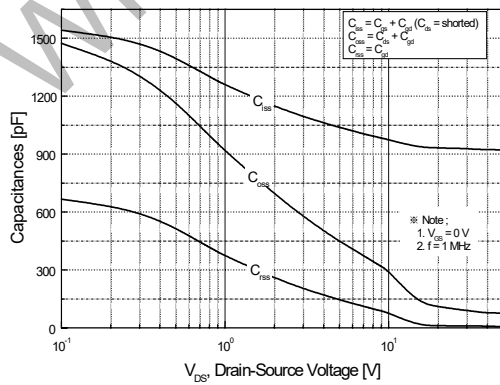
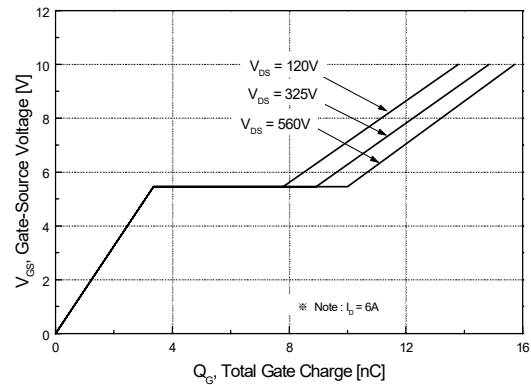

Figure 6. Gate Charge Characteristics



Typical Characteristics (Continued)

Figure 7. Breakdown Voltage Variation vs. Temperature

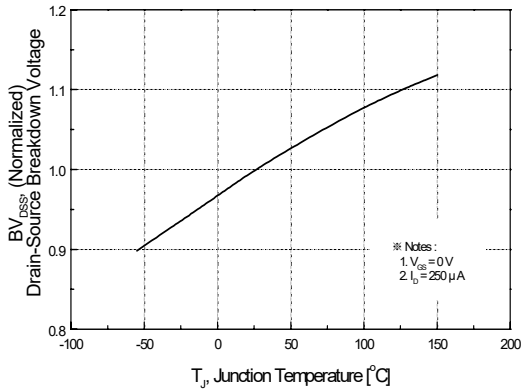

Figure 8. On-Resistance Variation vs. Temperature

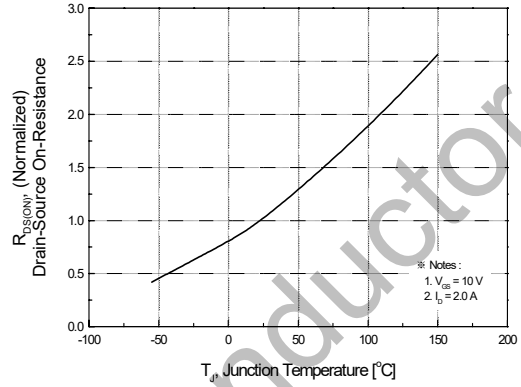

Figure 9. Maximum Safe Operating Area

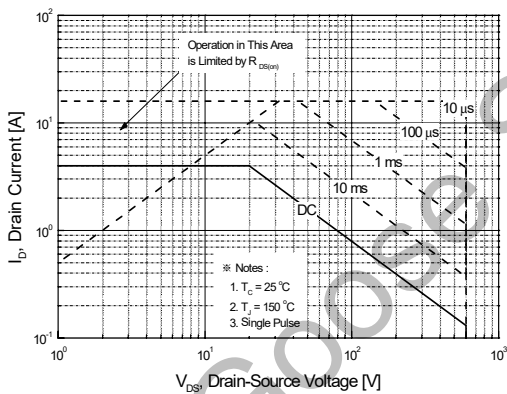

Figure 10. Maximum Drain Current vs. Case Temperature

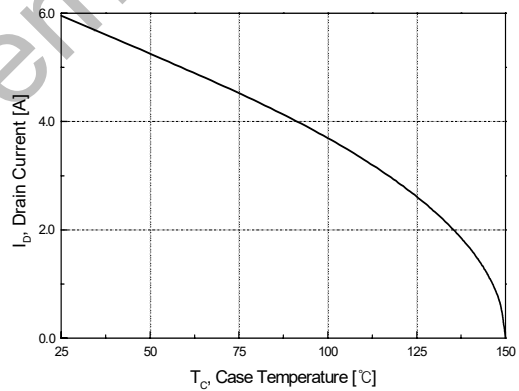
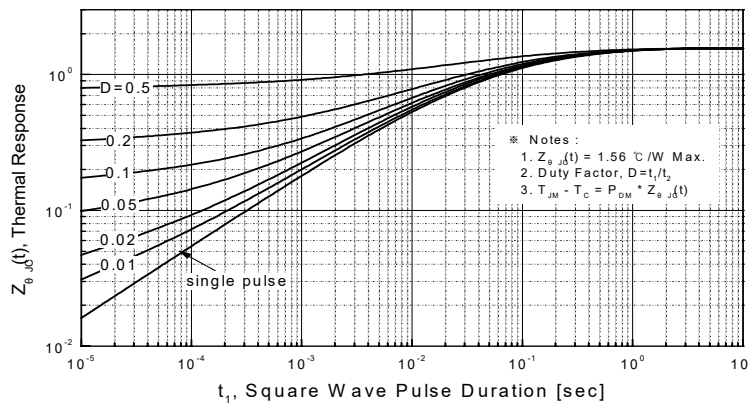
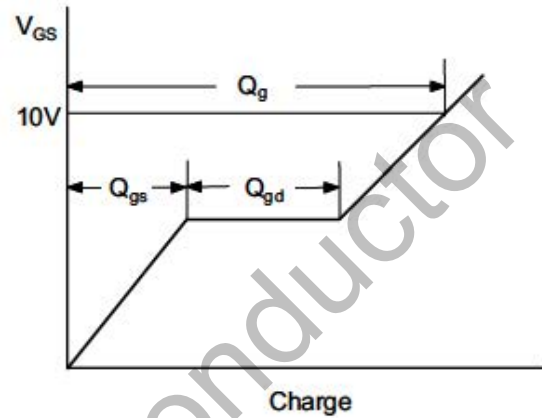
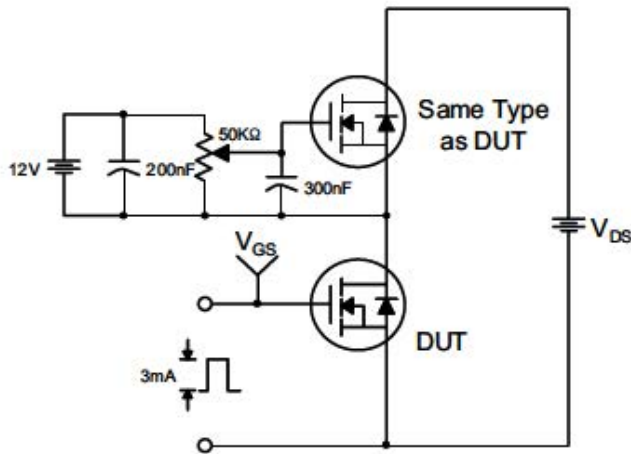

Figure 11 Transient Thermal Response Curve



Gate Charge Test Circuit & Waveform



Resistive Switching Test Circuit & Waveforms

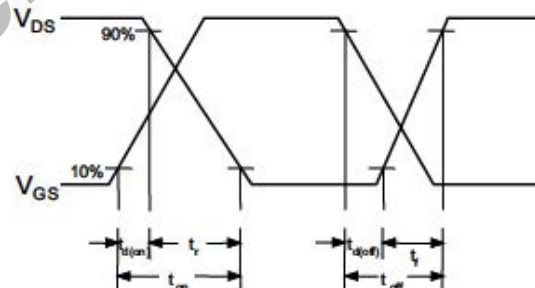
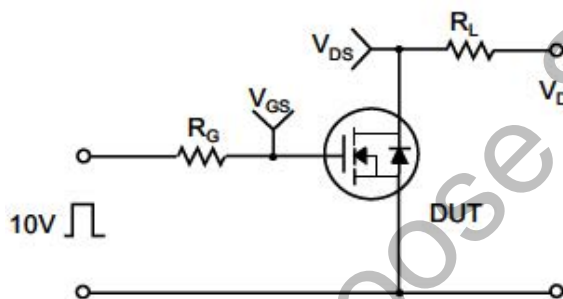

Unclamped Inductive Switching Test Circuit & Waveforms

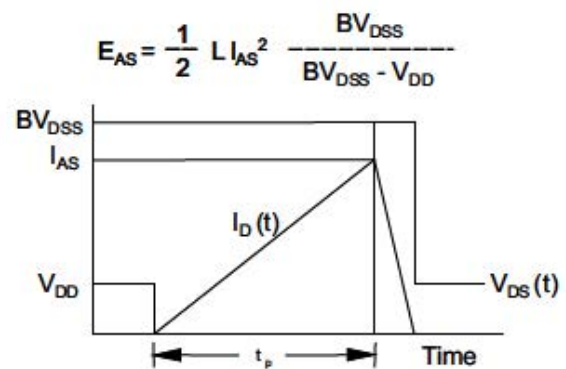
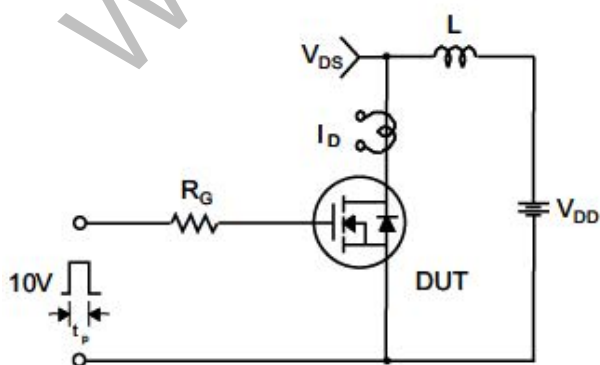

Peak Diode Recovery dv/dt Test Circuit & Waveforms

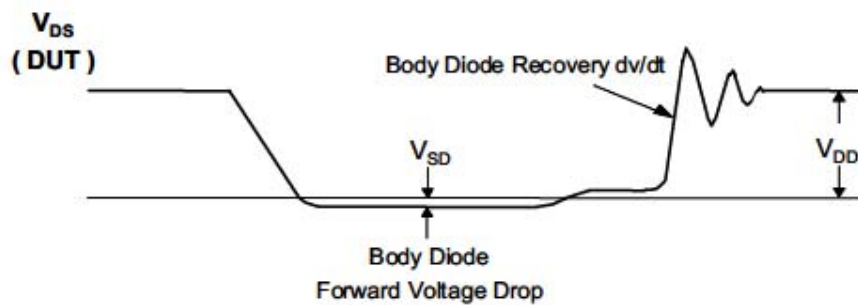
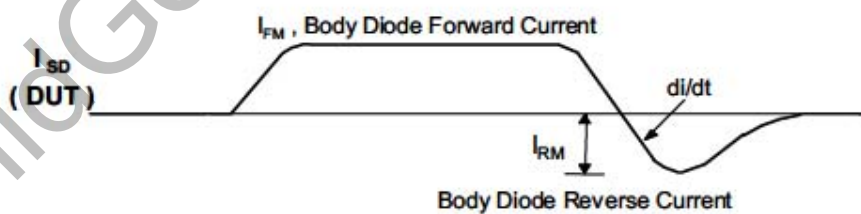
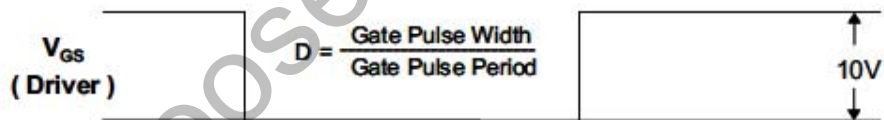
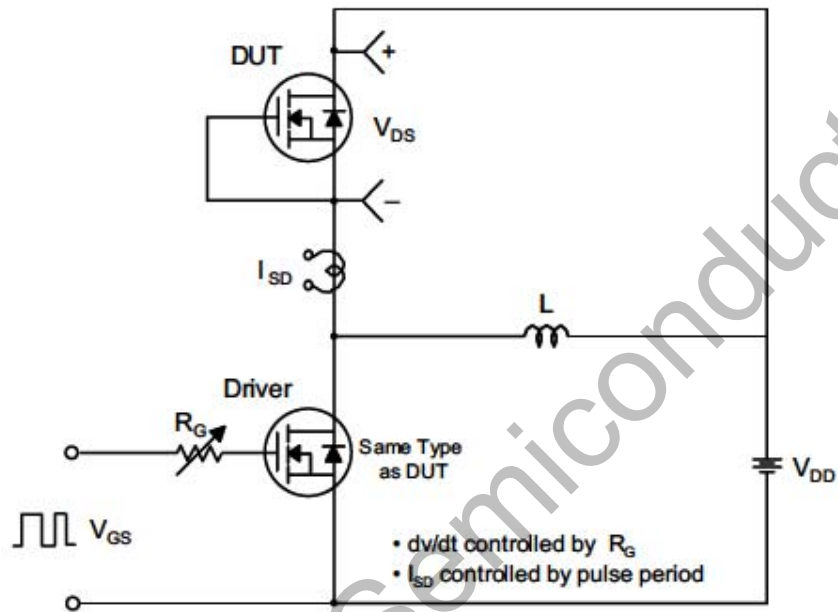

**Package Dimension**

TO-220

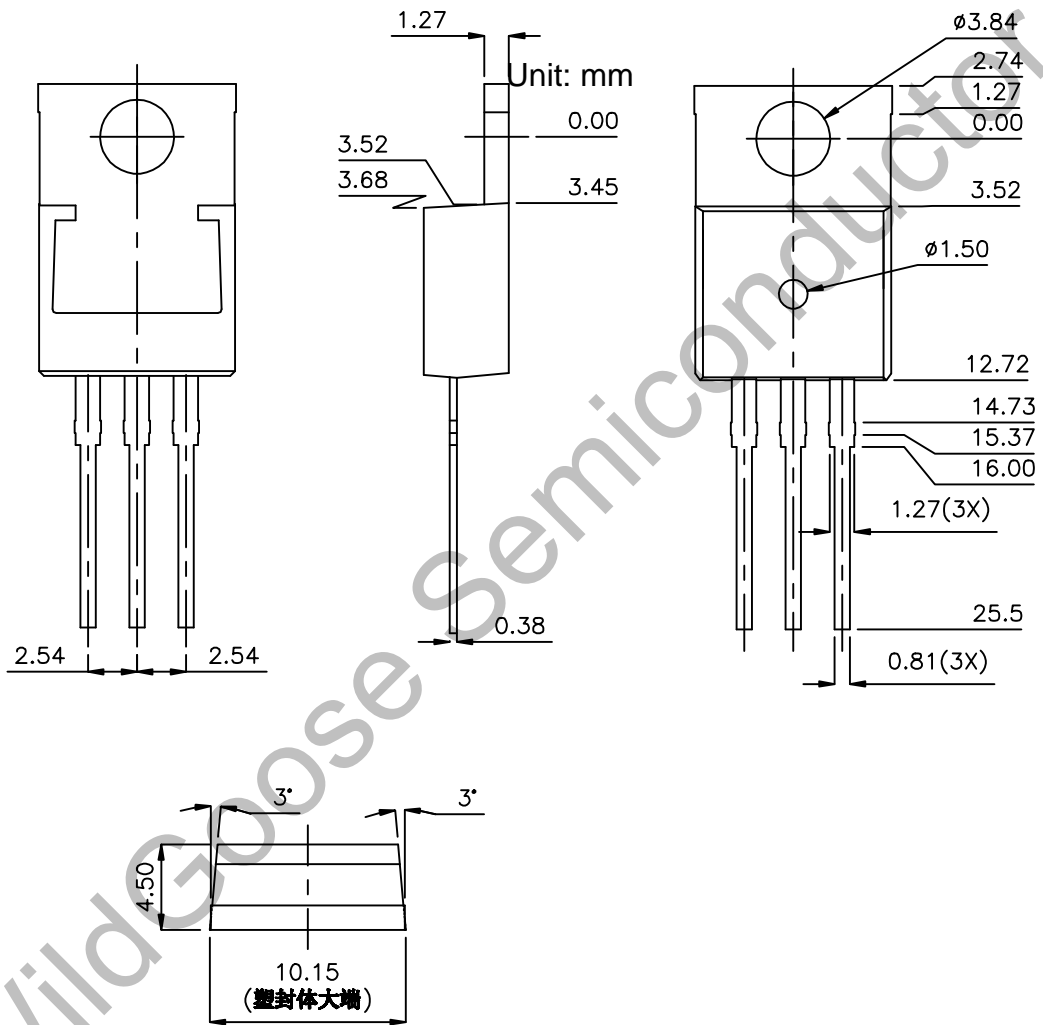

## X-ON Electronics

Largest Supplier of Electrical and Electronic Components

*Click to view similar products for [MOSFET](#) category:*

*Click to view products by [Wild Goose](#) manufacturer:*

Other Similar products are found below :

[IRFD120](#) [JANTX2N5237](#) [BUK455-60A/B](#) [MIC4420CM-TR](#) [VN1206L](#) [NDP4060](#) [SI4482DY](#) [IPS70R2K0CEAKMA1](#) [SQD23N06-31L-GE3](#)  
[TK16J60W,S1VQ\(O](#) [2SK2614\(TE16L1,Q\)](#) [DMN1017UCP3-7](#) [DMN1053UCP4-7](#) [SQJ469EP-T1-GE3](#) [NTE2384](#) [DMC2700UDMQ-7](#)  
[DMN2080UCB4-7](#) [DMN61D9UWQ-13](#) [US6M2GTR](#) [DMN31D5UDJ-7](#) [DMP22D4UFO-7B](#) [DMN1006UCA6-7](#) [DMN16M9UCA6-7](#)  
[STF5N65M6](#) [IRF40H233XTMA1](#) [STU5N65M6](#) [DMN6022SSD-13](#) [DMN13M9UCA6-7](#) [DMTH10H4M6SPS-13](#) [DMN2990UFB-7B](#)  
[IPB80P04P405ATMA2](#) [2N7002W-G](#) [MCAC30N06Y-TP](#) [MCQ7328-TP](#) [BXP7N65D](#) [BXP4N65F](#) [AOL1454G](#) [WMJ80N60C4](#) [BXP2N20L](#)  
[BXP2N65D](#) [BXT1150N10J](#) [BXT1700P06M](#) [TSM60NB380CP ROG](#) [RQ7L055BGTCR](#) [DMNH15H110SK3-13](#) [SLF10N65ABV2](#)  
[BSO203SP](#) [BSO211P](#) [IPA60R230P6](#) [IPA60R460CE](#)