

**ESD5302F**
**2-Lines, Uni-directional, Ultra-low Capacitance  
Transient Voltage Suppressors**
**Descriptions**

The ESD5302F is an ultra-low capacitance TVS (Transient Voltage Suppressor) array designed to protect high speed data interfaces. It has been specifically designed to protect sensitive electronic components which are connected to data and transmission lines from over-stress caused by ESD (Electrostatic Discharge).

The ESD5302F incorporates two pairs of ultra- low capacitance steering diodes plus a TVS diode.

The ESD5302F may be used to provide ESD protection up to  $\pm 20\text{kV}$  (contact and air discharge) according to IEC61000-4-2, and withstand peak pulse current up to 4A ( $8/20\mu\text{s}$ ) according to IEC61000-4-5.

The ESD5302F is available in SOT-23 package. Standard products are Pb-free and Halogen-free.

**Features**

- Stand-off voltage: 5V Max
- Transient protection for each line according to IEC61000-4-2 (ESD):  $\pm 20\text{kV}$  (contact and air discharge)  
IEC61000-4-4 (EFT): 40A (5/50ns)  
IEC61000-4-5 (surge): 4A ( $8/20\mu\text{s}$ )
- Ultra-low capacitance:  $C_J = 0.4\text{pF}$  typ.
- Ultra-low leakage current:  $I_R < 1\text{nA}$  typ.
- Low clamping voltage:  $V_{CL} = 20\text{V}$  @  $I_{PP} = 16\text{A}$ (TLP)
- Solid-state silicon technology

**Applications**

- USB 2.0 and USB 3.0
- HDMI 1.3 and HDMI 1.4
- SATA and eSATA
- DVI
- IEEE 1394
- PCI Express
- Portable Electronics
- Notebooks

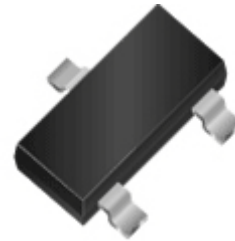
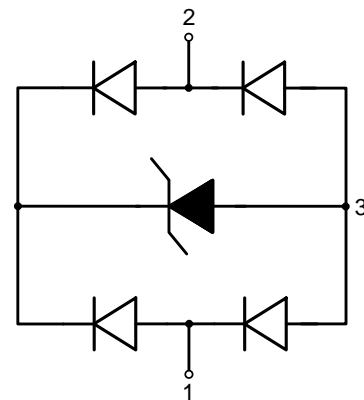
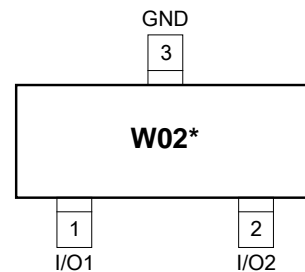
<http://www.sh-willsemi.com>

**SOT-23 (Top View)**

**Circuit diagram**

W = Will

02 = Device code

\* = Month code ( A~Z)

**Marking (Top View)**
**Order information**

Device	Package	Shipping
ESD5302F-3/TR	SOT-23	3000/Tape&Reel

**Absolute maximum ratings**

Parameter	Symbol	Rating	Unit
Peak pulse power ( $t_p = 8/20\mu s$ )	$P_{pk}$	60	W
Peak pulse current ( $t_p = 8/20\mu s$ )	$I_{PP}$	4	A
ESD according to IEC61000-4-2 air discharge	$V_{ESD}$	$\pm 20$	kV
ESD according to IEC61000-4-2 contact discharge		$\pm 20$	
Junction temperature	$T_J$	125	$^{\circ}C$
Operating temperature	$T_{OP}$	-40~85	$^{\circ}C$
Lead temperature	$T_L$	260	$^{\circ}C$
Storage temperature	$T_{STG}$	-55~150	$^{\circ}C$

**Electrical characteristics ( $T_A=25^{\circ}C$ , unless otherwise noted)**

Parameter	Symbol	Condition	Min.	Typ.	Max.	Unit
Reverse maximum working voltage	$V_{RWM}$				5.0	V
Reverse leakage current	$I_R$	$V_{RWM} = 5V$		<1	100	nA
Reverse breakdown voltage	$V_{BR}$	$I_T = 1mA$	7.0	8.0	9.0	V
Forward voltage	$V_F$	$I_T = 10mA$	0.6	0.9	1.2	V
Clamping voltage <sup>1)</sup>	$V_{CL}$	$I_{PP} = 16A, t_p = 100ns$		20		V
Dynamic resistance <sup>1)</sup>	$R_{DYN}$			0.65		$\Omega$
Clamping voltage <sup>2)</sup>	$V_{CL}$	$I_{PP} = 1A, t_p = 8/20\mu s$			11	V
		$I_{PP} = 4A, t_p = 8/20\mu s$			15	V
Junction capacitance	$C_J$	$V_R = 0V, f = 1MHz$ Any I/O pin to GND		0.40	0.65	pF
		$V_R = 0V, f = 1MHz$ Between any I/O pin		0.25	0.40	pF

Notes:

- 1) TLP parameter:  $Z_0 = 50 \Omega$ ,  $t_p = 100ns$ ,  $t_r = 2ns$ , averaging window from 60ns to 80ns.  $R_{DYN}$  is calculated from 4A to 16A.
- 2) According to IEC61000-4-5.

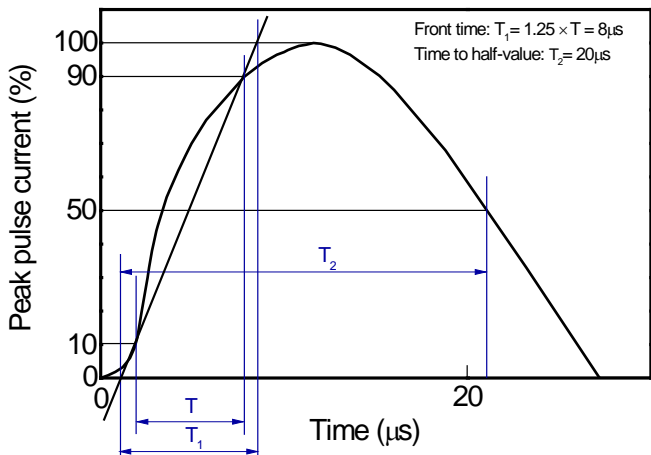
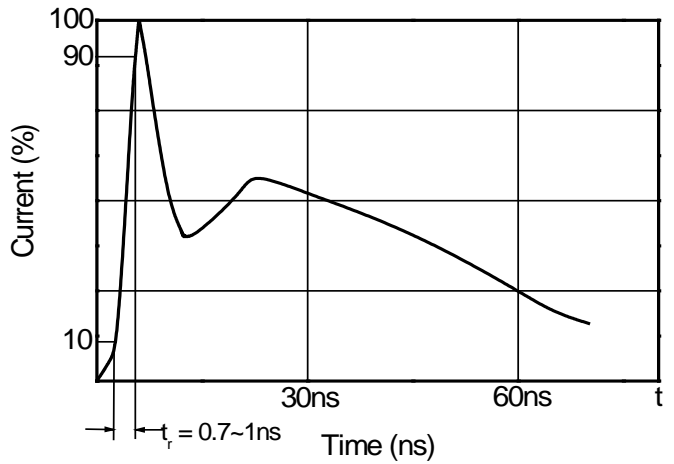
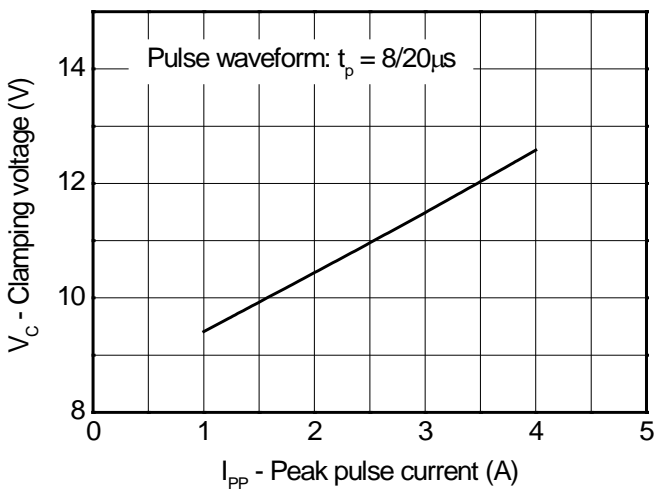
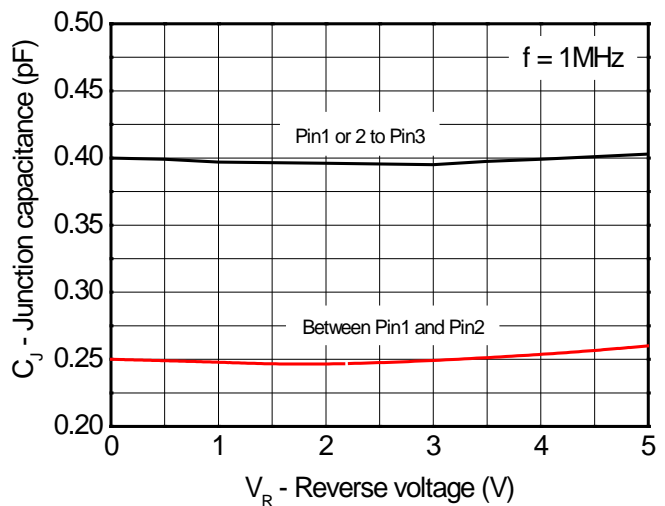
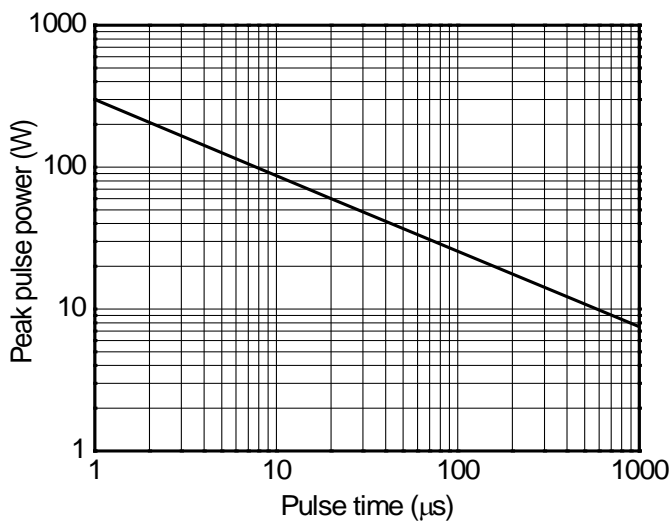
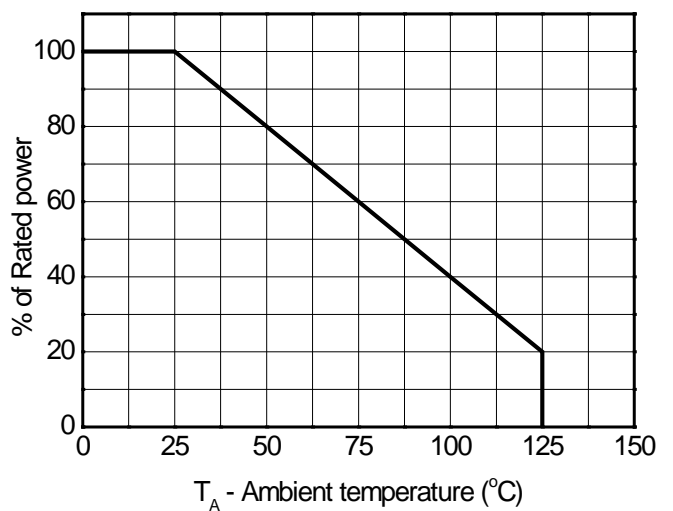
**Typical characteristics ( $T_A=25^\circ\text{C}$ , unless otherwise noted)**

**8/20μs waveform per IEC61000-4-5**

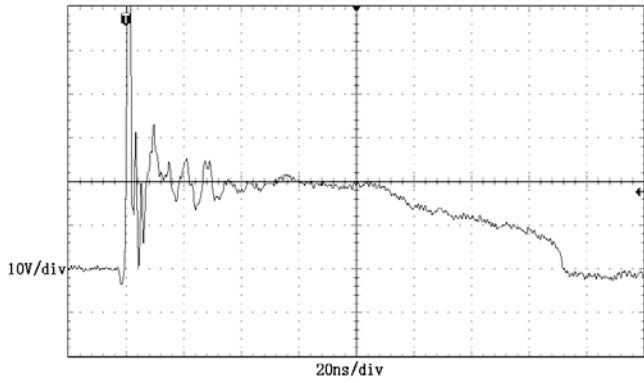
**Contact discharge current waveform per IEC61000-4-2**

**Clamping voltage vs. Peak pulse current**

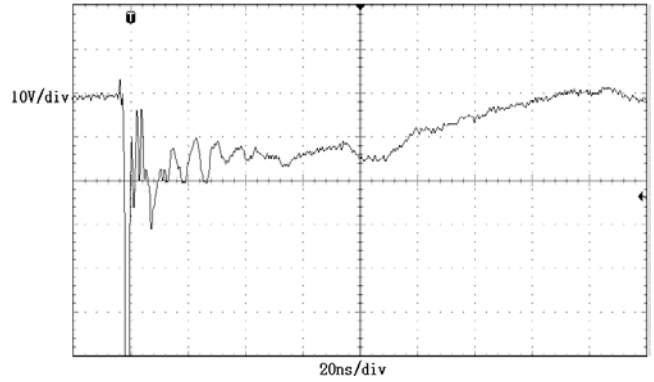
**Capacitance vs. Reverse voltage**

**Non-repetitive peak pulse power vs. Pulse time**

**Power derating vs. Ambient temperature**

Typical characteristics ( $T_A=25^\circ\text{C}$ , unless otherwise noted)



**ESD clamping**  
(+8kV contact discharge per IEC61000-4-2)



**ESD clamping**  
(-8kV contact discharge per IEC61000-4-2)

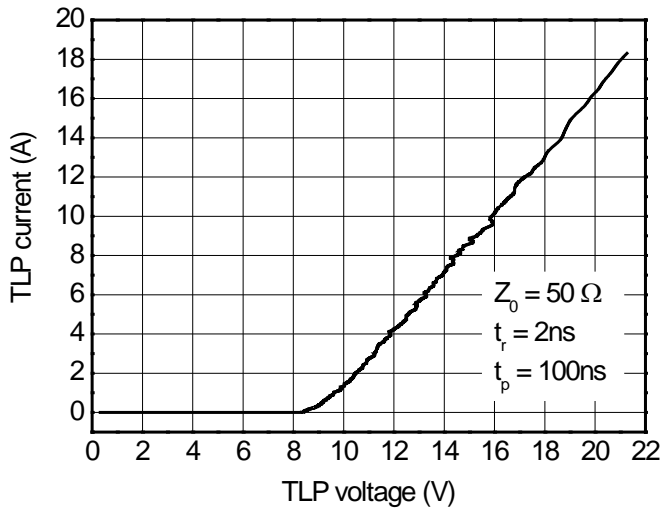

**TLP Measurement**

**Application Information**

The ESD5302F is designed to protect two high speed line against ESD. Fig1 is shown the connection and Fig2 is shown PCB Layout guide for USB interface ESD protection

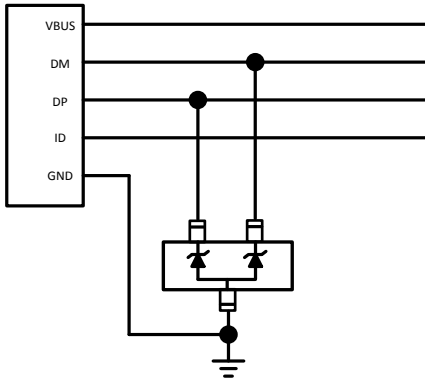

Fig1

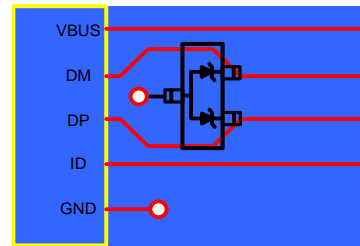
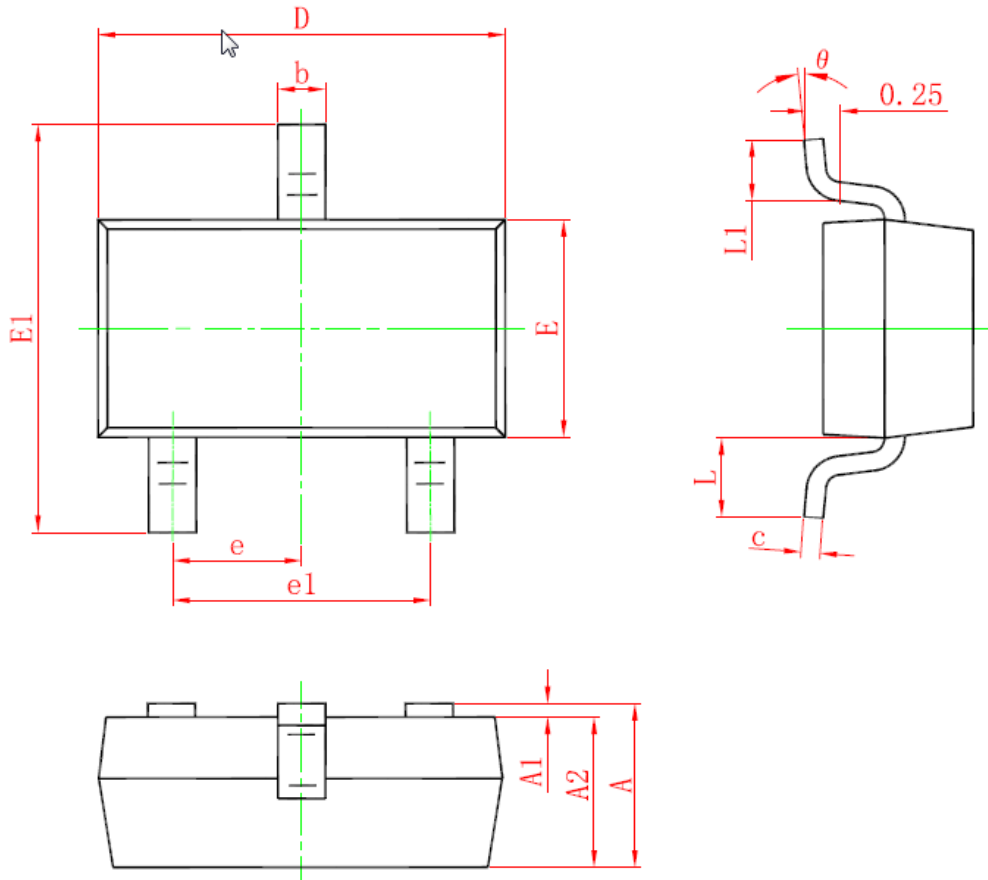

Fig2

**Package outline dimensions**
**SOT-23**

Symbol	Dimensions in millimeter		Dimensions in inches	
	Min.	Max.	Min.	Max.
A	0.900	1.150	0.035	0.045
A1	0.000	0.100	0.000	0.004
A2	0.900	1.050	0.035	0.041
b	0.300	0.500	0.012	0.020
c	0.080	0.150	0.003	0.006
D	2.800	3.000	0.110	0.118
E	1.200	1.400	0.047	0.055
E1	2.250	2.550	0.089	0.100
e	0.950TYP		0.037TYP	
e1	1.800	2.000	0.071	0.079
L	0.550REF		0.022REF	
L1	0.300	0.500	0.012	0.020
θ	0°	8°	0°	8°

## X-ON Electronics

Largest Supplier of Electrical and Electronic Components

*Click to view similar products for [ESD Suppressors / TVS Diodes](#) category:*

*Click to view products by [Will Semiconductor](#) manufacturer:*

Other Similar products are found below :

[NTE4902](#) [P4SMAJ15A](#) [P4SMAJ26A](#) [SMAJ400CA-TP](#) [TGL34-47CA](#) [ESDAULC45-1BF4](#) [SM1605E3/TR13](#) [SMF20A-TP](#) [P4SMAJ12A](#)  
[CPDUR24V-HF](#) [CPDQC5V0USP-HF](#) [CPDQC5V0-HF](#) [MPLAD30KP45CAE3](#) [MMBZ27VCLQ-7-F](#) [MMAD1108/TR13](#) [MPLAD30KP24A](#)  
[ACPDQC5V0R-HF](#) [DFLT170A-7](#) [NTE4900](#) [NTE4926](#) [NTE4938](#) [SMF22A-TP](#) [SMF12A-TP](#) [SLVU2.8-TP](#) [SMLJ6.5CA-TP](#) [SMAJ6.5CA-](#)  
[TP](#) [MMAD1108E3/TR13](#) [D5V0M1U2LP3-7](#) [SMAJ400A-TP](#) [AOZ8811DT-03](#) [AOZ8831DI-05](#) [AOZ8831DT-03](#) [SMAJ188CA](#) [3SMC33CA](#)  
[BK](#) [CPDQC3V3C-HF](#) [CPDQC12VE-HF](#) [MPLAD30KP170CA](#) [82357120100](#) [5.0SMLJ15CA-TP](#) [5KP18A-TP](#) [P6KE8.2A-TP](#)  
[MPLAD30KP43CAE3](#) [SMAJ43A-TP](#) [D5V0F6U8LP33-7](#) [TVS5501V10MUT5G](#) [5.0SMLJ24CA-TP](#) [SMAJ110CA-TP](#) [MPLAD15KP75CAE3](#)  
[MMAD1103e3/TR13](#) [DFLT40AQ-7](#)