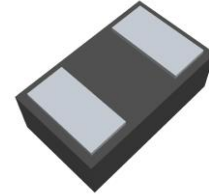

ESD56281NXX
1-Line, Uni-directional, Transient Voltage Suppressors
<http://www.omnivision-group.com>
Descriptions

The ESD56281NXX is a transient voltage suppressor designed to protect power interfaces. It is suitable to replace multiple discrete components in portable electronics.

The ESD56281NXX is specifically designed to protect USB port and power lines.

The ESD56281NXX is available in DFN1006-2L package. Standard products are Pb-free and Halogen-free.

DFN1006-2L (Bottom View)
Features

- Reverse stand-off voltage: 4.85V ~ 6.3V
- Surge protection according to IEC61000-4-5 see [Table 4](#)
- ESD protection according to IEC61000-4-2 ±30kV (contact and air discharge)
- Low clamping voltage
- Solid-state silicon technology

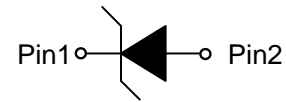
Circuit diagram
Applications

- Cell phone handsets and accessories
- Power supply protection
- Power management



X = Device code (Y, Z, Q)

* = Month code (A~Z)

Marking (Top View)
Order information
Table 1.

Device	Package	Shipping	Marking
ESD56281N04-2/TR	DFN1006-2L	10000/Tape&Reel	<u>Y</u> *
ESD56281N05-2/TR	DFN1006-2L	10000/Tape&Reel	<u>Z</u> *
ESD56281N06-2/TR	DFN1006-2L	10000/Tape&Reel	<u>Q</u> *

Absolute maximum ratings
Table 2.

Parameter	Symbol	Rating	Unit
Peak pulse power ($t_p=8/20\mu s$)	Ppk	350	W
ESD according to IEC61000-4-2 air discharge	V _{ESD}	±30	kV
ESD according to IEC61000-4-2 contact discharge		±30	
Junction temperature	T _J	125	°C
Operating temperature	T _{OP}	-40~85	°C
Lead temperature	T _L	260	°C
Storage temperature	T _{STG}	-55~150	°C

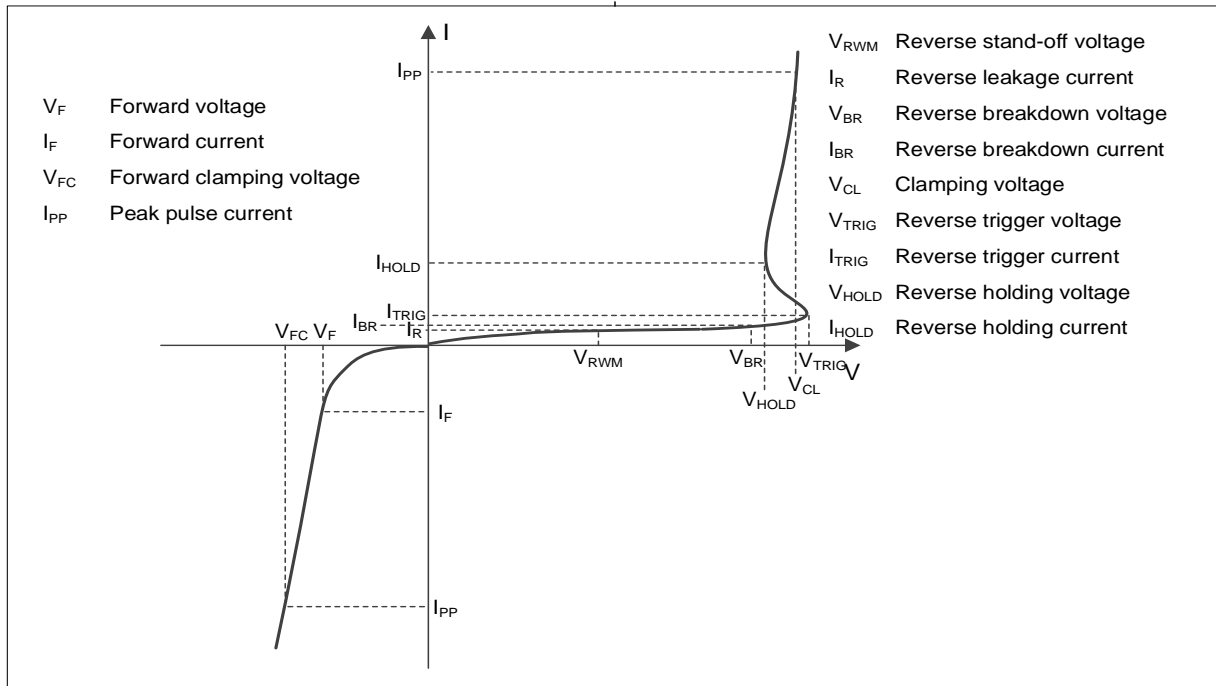
Electrical characteristics (T_A = 25°C, unless otherwise noted)

Definitions of electrical characteristics

Electrical characteristics ($T_A = 25^\circ\text{C}$, unless otherwise noted)
Table 3.

Type number	Reverse Stand off Voltage V_{RWM} (V)	Breakdown voltage V_{BR} (V) $I_{BR} = 1\text{mA}$			Reverse leakage current I_{RM} (nA) at V_{RWM}		Forward voltage V_F (V) $I_F = 20\text{mA}$		Junction capacitance $F=1\text{MHz}$, $V_R=0\text{V}$ (pF)	
	Max.	Min.	Typ.	Max.	Typ.	Max.	Min.	Max.	Typ.	Max.
ESD56281N04	4.85	5.0	5.5	6.0	1	100	0.5	1.1	170	180
ESD56281N05	5.5	5.6	6.4	7.5	1	100	0.5	1.1	160	170
ESD56281N06	6.3	6.5	7.5	9.0	1	100	0.5	1.1	90	100

Table 4.

Type number	Rated peak pulse current I_{PP} (A) ¹⁾³⁾	Clamping voltage Typ. V_{CL} (V) at I_{PP} (A) ¹⁾³⁾	Clamping voltage Typ. V_{CL} (V) at $I_{PP} = 16\text{A}$, $t_p = 100\text{ns}$ ²⁾³⁾	Clamping voltage Typ. V_{CL} (V) at $V_{ESD} = 8\text{kV}$ ²⁾³⁾
ESD56281N04	42	8.2	6.0	7.5
ESD56281N05	40	8.8	6.6	8.0
ESD56281N06	35	9.0	6.6	8.0

Notes:

- 1) Non-repetitive current pulse, according to IEC61000-4-5. (8/20 μs current waveform)
- 2) Non-repetitive current pulse, according to IEC61000-4-2.
- 3) Measured from pin 1 to pin 2.

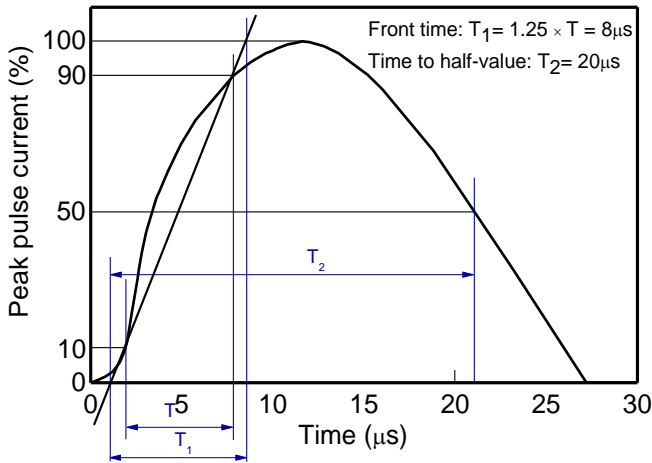
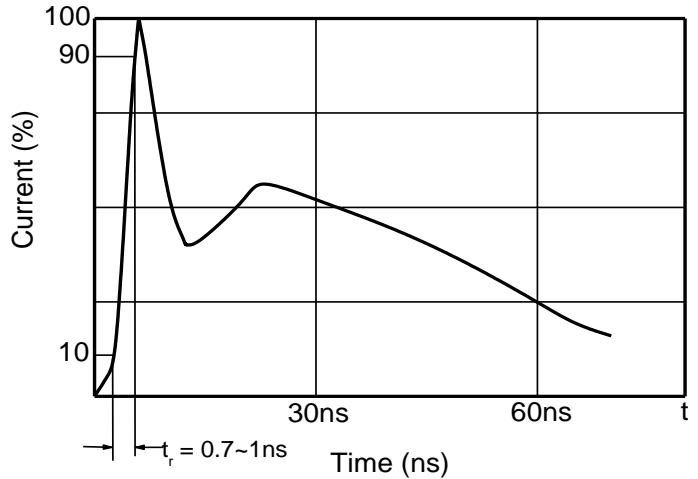
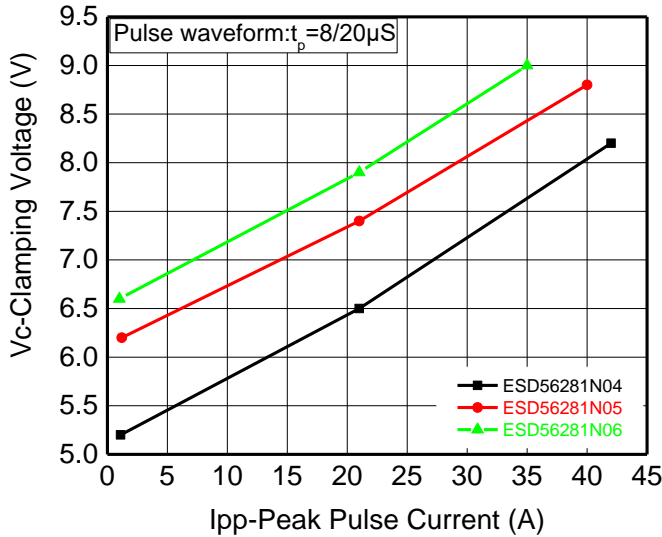
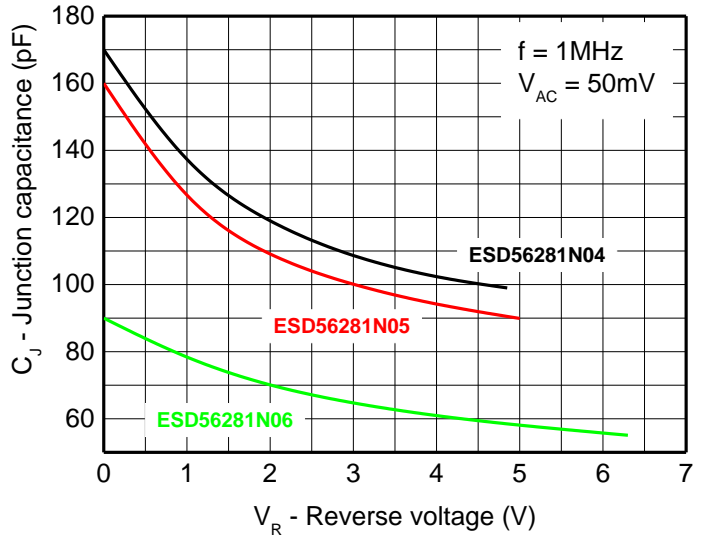
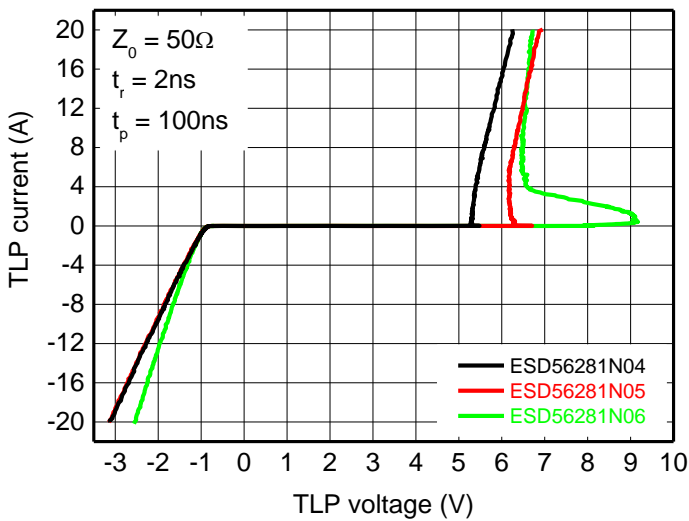
Typical characteristics ($T_A = 25^\circ\text{C}$, unless otherwise noted)

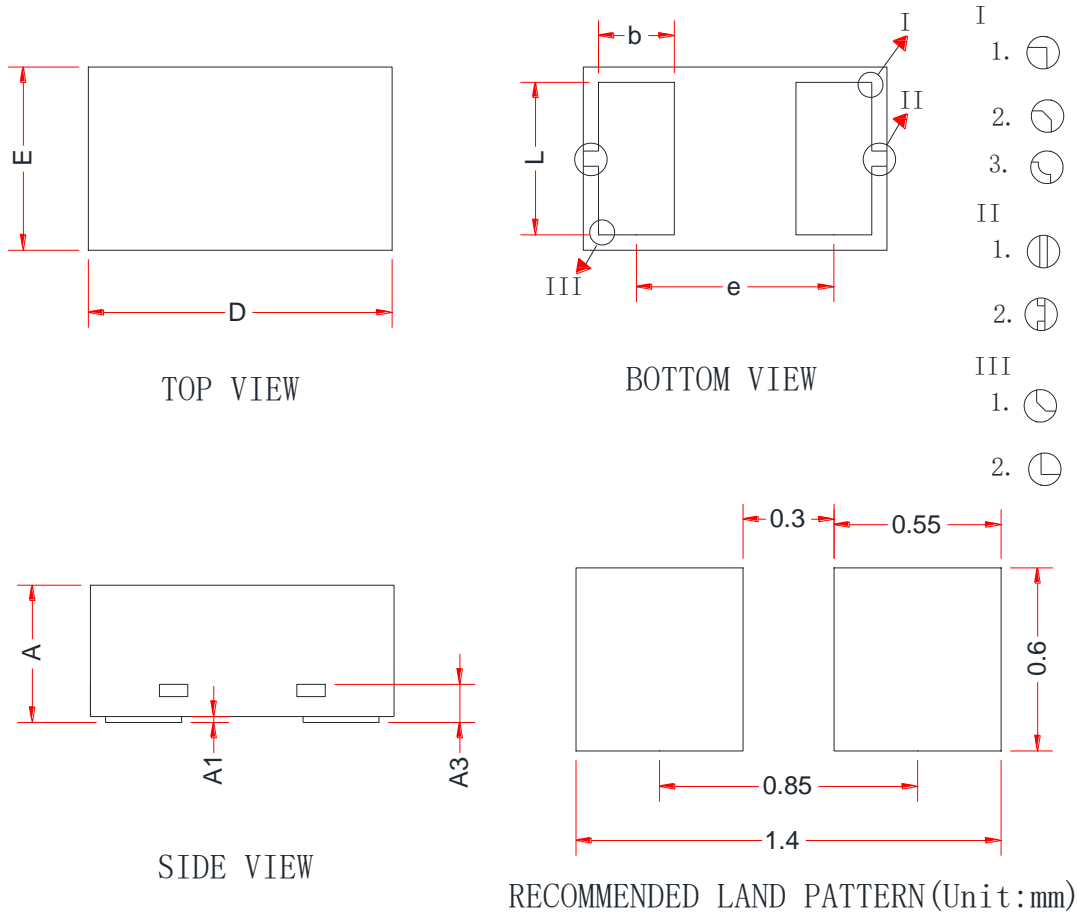
8/20 μs waveform per IEC61000-4-5

Contact discharge current waveform per IEC61000-4-2

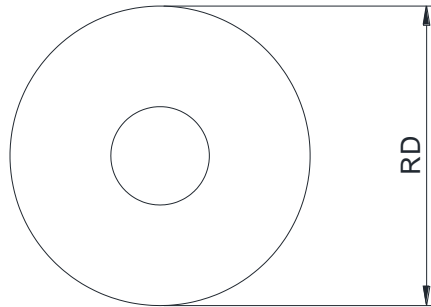
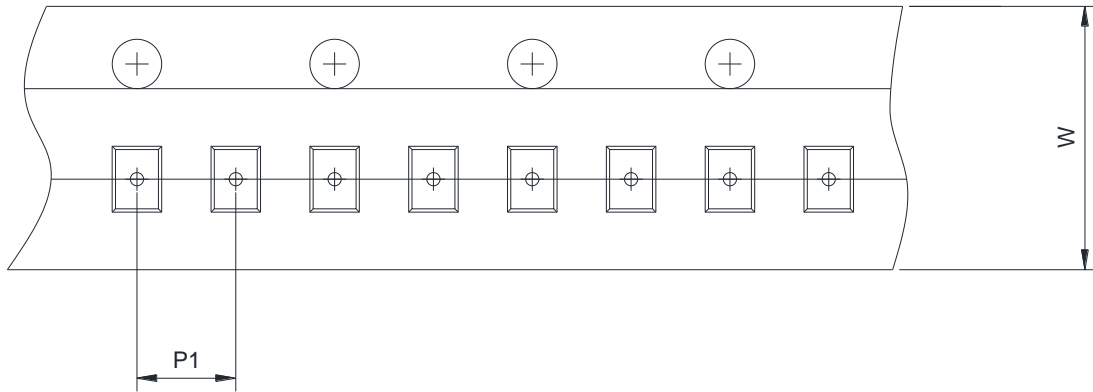
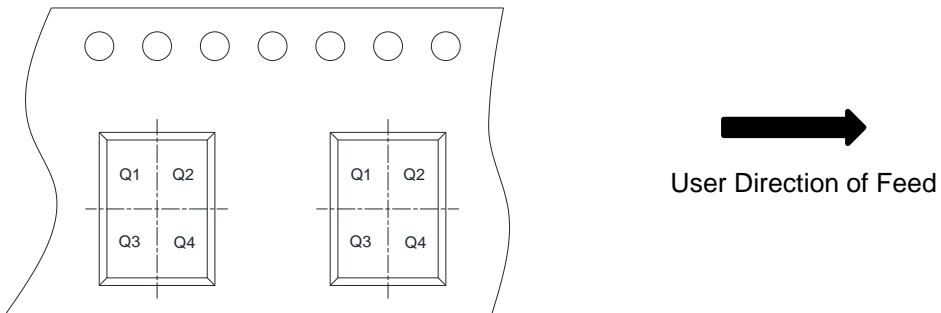
Clamping voltage vs. Peak pulse current

Capacitance vs. Reverse voltage

TLP Measurement

PACKAGE OUTLINE DIMENSIONS
DFN1006-2L

Symbol	Dimensions in Millimeters		
	Min.	Typ.	Max.
A	0.36	0.45	0.50
A1	0.00	0.02	0.05
A3	0.125 Ref.		
D	0.95	1.00	1.05
E	0.55	0.60	0.65
b	0.20	0.25	0.30
L	0.45	0.50	0.55
e	0.65 BSC		

TAPE AND REEL INFORMATION
Reel Dimensions

Tape Dimensions

Quadrant Assignments For PIN1 Orientation In Tape

RD	Reel Dimension	<input checked="" type="checkbox"/> 7inch <input type="checkbox"/> 13inch
W	Overall width of the carrier tape	<input checked="" type="checkbox"/> 8mm <input type="checkbox"/> 12mm <input type="checkbox"/> 16mm
P1	Pitch between successive cavity centers	<input checked="" type="checkbox"/> 2mm <input type="checkbox"/> 4mm <input type="checkbox"/> 8mm
Pin1	Pin1 Quadrant	<input checked="" type="checkbox"/> Q1 <input checked="" type="checkbox"/> Q2 <input type="checkbox"/> Q3 <input type="checkbox"/> Q4

X-ON Electronics

Largest Supplier of Electrical and Electronic Components

Click to view similar products for [ESD Suppressors / TVS Diodes](#) category:

Click to view products by [Will Semiconductor](#) manufacturer:

Other Similar products are found below :

[60KS200C](#) [D18V0L1B2LP-7B](#) [D5V0F4U5P5-7](#) [NTE4902](#) [P4KE27CA](#) [P6KE11CA](#) [P6KE39CA-TP](#) [P6KE8.2A](#) [JANTX1N6053A](#)
[SA110CA](#) [SA60CA](#) [SA64CA](#) [SMBJ12CATR](#) [SMBJ33CATR](#) [SMBJ8.0A](#) [ESD105-B1-02EL E6327](#) [ESD112-B1-02EL E6327](#)
[ESD119B1W01005E6327XTSA1](#) [ESD5V0L1B02VH6327XTSA1](#) [ESD7451N2T5G](#) [19180-510](#) [CPDT-5V0USP-HF](#) [3.0SMCJ33CA-F](#)
[3.0SMCJ36A-F](#) [HSPC16701B02TP](#) [JANTX1N6126A](#) [JANTX1N6462](#) [JANTX1N6465](#) [USB50805e3/TR7](#) [D3V3Q1B2DLP3-7](#)
[D55V0M1B2WS-7](#) [DRTR5V0U4SL-7](#) [SCM1293A-04SO](#) [ESD200-B1-CSP0201 E6327](#) [SM12-7](#) [SM1605E3/TR13](#) [SMLJ45CA-TP](#) [CEN955](#)
[W/DATA](#) [82350120560](#) [VESD12A1A-HD1-GS08](#) [CPDUR5V0R-HF](#) [CPDQC5V0U-HF](#) [CPDQC5V0USP-HF](#) [CPDQC5V0-HF](#) [D1213A-](#)
[01LP4-7B](#) [ESD101-B1-02EL E6327](#) [824500181](#) [MMAD1108/TR13](#) [5KP100A](#) [5KP15A](#)