

WD3153

3-Channel LED Driver

[Http://:www.sh-willsemi.com](http://www.sh-willsemi.com)

Descriptions

The WD3153 is a 3-channel LED driver designed to produce variety of lighting effects. The device has a program memory for creating variety of lighting sequences. When the program memory has been loaded, the WD3153 can operate independently without processor control.

Three independent LED channels have accurate programmable current sinks, from 0mA to 25mA with 5 steps and 8-bit flexible PWM control. Each channel can be configured into each of the three program execution engines. Program execution engines have program memory for creating desired lighting sequences with PWM control.

Features

- Supply voltage: 2.4V to 5.5V
- Three independently programmable LED outputs with 8-bit PWM control and 3-bit current setting (from 0mA to 25mA)
- Autonomous operation with three program execution engines
- Direct I²C register control for lighting
- I²C Compatible Interface
 - Power supply support 1.8V to 5.5V
 - Data transfers up to 400kbps
- INTN interrupt function
- Typical LED output saturation voltage 80mV
- LED output current accuracy ±2% and current matching ±1%
- Built-in oscillator with ±5% accuracy
- Support charging indication under low battery condition
 - Directly start up breathing light on LED0
 - Breathing period: 5s or continuous
- Low power consumption
 - Operating current: 80uA
 - Less than 1uA in shut down mode

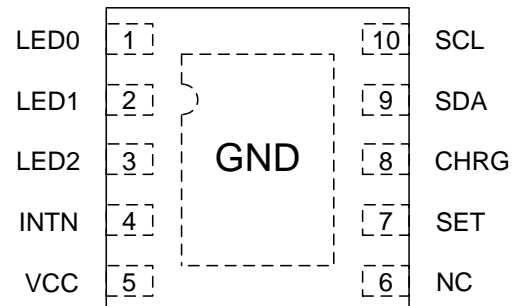

Pin configuration (Top view)

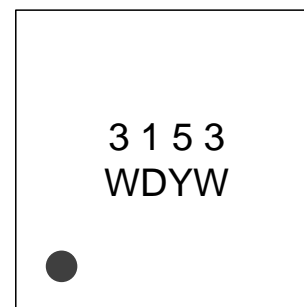

DFN2X2-10L

3153 = Device code
Y = Year code
W = Week code
Marking

Order information

Device	Package	Shipping
WD3153D-10/TR	DFN2X2-10L	3000/Reel&Tape

- Operating temperature: -40°C to 85°C
- ESD HBM 4kV
- DFN2X2-10L package

Applications

- Smart Phones
- Tablets
- Indicator lights

Typical applications

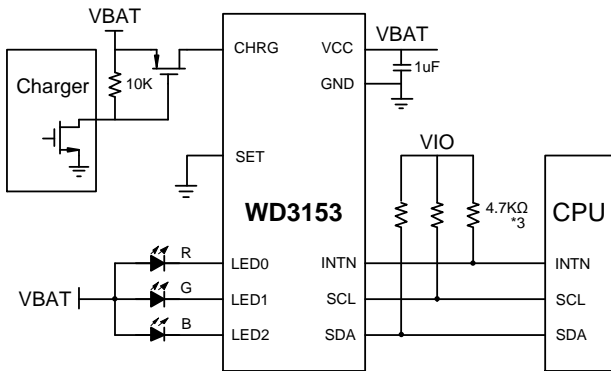

Fig1 Charging Indicator Application

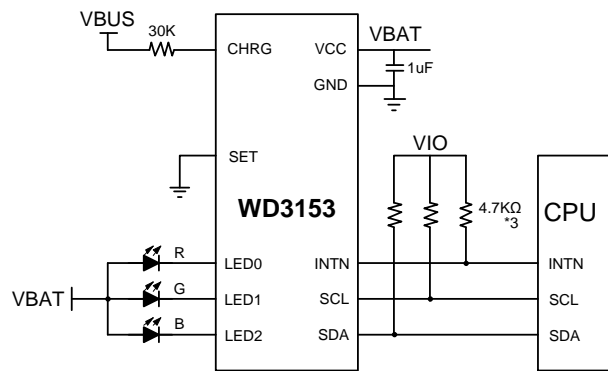
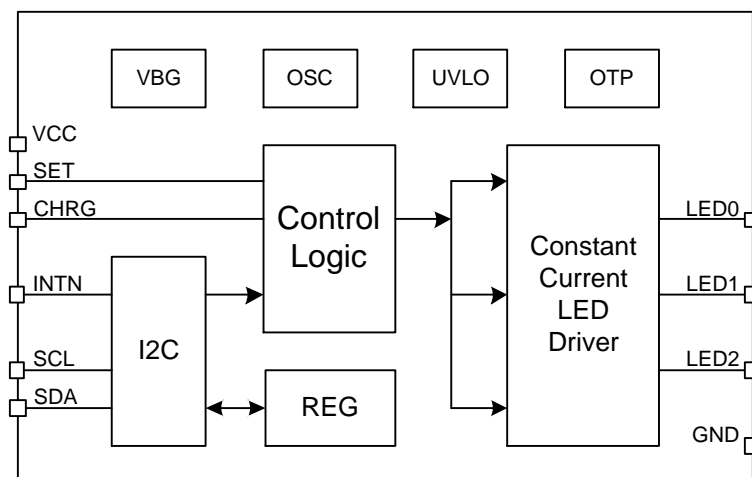

Fig2 Adapter Plug In Indicator Application

Pin descriptions

No.	Name	I/O	Description
1	LED0	Analog	LED driver current sink terminal
2	LED1	Analog	LED driver current sink terminal
3	LED2	Analog	LED driver current sink terminal
4	INTN	Open drain	Interrupt output
5	VCC	Power	2.4V~5.5V power supply
6	NC		Not internally connected
7	SET	I	Charge indicator set. 0: LED0 output 5mA/5S period 1: LED0 output 5mA continuous
8	CHRG	I	Charge indicator input. Internal pull-down resistor of 15KΩ between CHRG and GND.
9	SDA	I/O	I ² C serial interface data input/output. 1.8V/5.5V compatible
10	SCL	I	I ² C serial interface clock. 1.8V/5.5V compatible
EP	GND	Ground	Connect to ground.

Block diagram



Absolute maximum ratings (1)

Parameter	MIN	MAX	Unit
Power supply VCC	-0.3	6.0	V
Analog pins (LED0, LED1, LED2)	-0.3	6.0	V
Digital pins (SDA, SCL, INTN)	-0.3	VCC+0.3V with 6.0 max	V
Storage temperature T _{stg}	-65	150	°C
Junction temperature T _{JMAX}		150	°C
Maximum lead temperature		260	°C
Junction-to-ambient thermal resistance (DFN10L)	45		°C/W
ESD HBM	-4	4	kV
Latch-up	-450	450	mA

(1) Stresses beyond those listed under "absolute maximum ratings" may cause permanent damage to the device. These are stress ratings only and functional operation of the device at these or any other conditions beyond those indicated under "recommended operating conditions" is not implied. Exposure to absolute-maximum-rated conditions for extended periods may affect device reliability.

Recommended Operating Conditions

Parameter	MIN	MAX	Unit
Power supply VCC	2.4	5.5	V
Digital pins	1.8	VCC	V
Junction temperature T _J	-40	125	°C
Ambient temperature T _A	-40	85	°C

Electronics Characteristics

Unless otherwise specified, TA = 25°C and VCC = 3.6V.

Symbol	Description	Test Conditions	MIN	TYP	MAX	Unit
I _{SD}	Shut down current	CHIPEN=0 (device off)		0.1	1	uA
I _{SB}	Standby current	CHIPEN=1 (device on); LE0~2=0 (all LEDs off)		35	50	uA
I _{CC}	Operating current	CHIPEN=1 (device on); LE0~2=1 (all LEDs on); LCFG0~2=03h (all LEDs set to 15mA);		80	120	uA
F _{OSC}	Oscillator frequency	Internal	-5		5	%
LED driver (LED0, LED1, LED2) electrical characteristics (GCR=01h, PWM0~2=FFh)						
I _{MAX}	Maximum sink current	LCFG0~2=04h	24.25	25	25.75	mA
		LCFG0~2=03h	14.55	15	15.45	
		LCFG0~2=02h	9.7	10	10.3	
		LCFG0~2=01h	4.85	5	5.15	
		LCFG0~2=00h		0		
I _{match}	Matching (2)	LCFG0~2=03h, 15mA Set	-1		+1	%
V _{SAT}	Saturation voltage (3)	LCFG0~2=03h		80	100	mV
F _{LED}	PWM switching frequency	PWM_HF=0	237.5	250	262.5	Hz
		PWM_HF=1	475	500	525	Hz

(2) Output current accuracy is the difference between the actual value of the output current and programmed value of this current. Matching is the maximum difference from the average. For the constant current outputs on the part, the following are determined: the maximum output current (MAX), the minimum output current (MIN), and the average output current of all outputs (AVG). Two matching numbers are calculated: (MAX - AVG)/AVG and (AVG - MIN)/AVG. The largest number of the two (worst case) is considered the matching figure. Note that some manufacturers have different definitions in use.

(3) Saturation voltage is defined as the voltage when the LED current has dropped 10% from the set value.

Logic interface characteristics

Unless otherwise specified: limits for typical values are for $T_A = 25^\circ\text{C}$ and minimum and maximum limits apply over the operating ambient temperature range ($-40^\circ\text{C} < T_A < 85^\circ\text{C}$); $V_{CC}=3.6\text{V}$ and range ($2.4\text{V} < V_{CC} < 5.5\text{V}$).

Symbol	Description	MIN	TYP	MAX	Unit
V_{DD_I2C}	Power supply range for I ² C	1.65		5.5	V
Logic input SCL and SDA characteristics					
V_{IH}	Input high level	1.2			V
V_{IL}	Input low level			0.6	V
I_{IH}	High level input current		5		nA
I_{IL}	Low level input current		5		nA
Logic output SDA characteristics					
V_{OL}	Output low level ($I_{OUT} = 3\text{mA}$)		0.3	0.5	V
I_L	Output leakage current			1	uA
I²C timing requirements (4)					
F_{SCL}	I ² C clock frequency			400	kHz
t_{BUF}	Bus-free time between a STOP and a START condition	1.3			uS
$t_{HD,STA}$	Hold time (repeated) START condition	0.6			uS
t_{LOW}	Clock low time	1.3			uS
t_{HIGH}	Clock high time	0.6			uS
$t_{SU,STA}$	Setup time for a repeated START condition	1.3			uS
$t_{HD,DAT}$	Data hold time	0.05			uS
$t_{SU,DAT}$	Data setup time	0.1			uS
t_R	Rise time of SCL			0.3	uS
t_F	Fall time of SCL			0.3	uS
$t_{SU,STO}$	Set-up time for STOP condition	0.6			uS
T_{SP}	SCL input deglitch			200	nS
	SDA input deglitch			250	nS
C_b	Capacitive load for each bus line			400	pF

(4) Specification is ensured by design and is not tested in production.

Fig4 is the timing parameters of I²C interface (SCL, SDA).

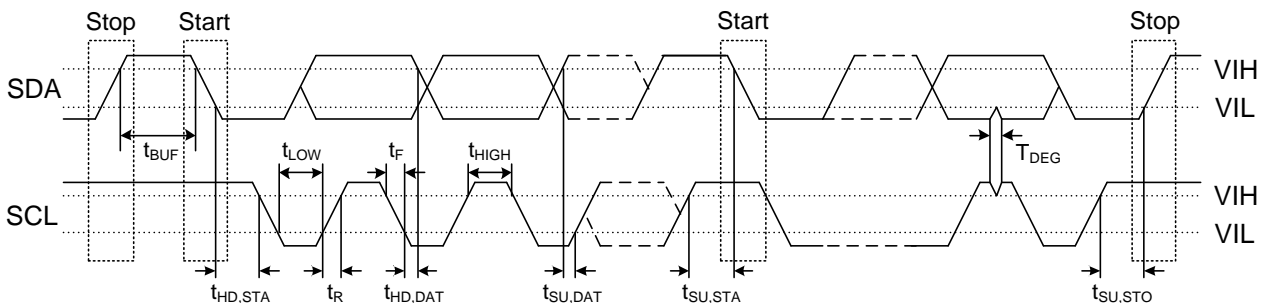

Fig4 I²C timing parameters

Option Mode

Power On Reset

Power On Reset (POR) will activate when VCC rises above 2V (typical), which will reset all the internal registers to the default values, and then the chip will enter the Shut Down Mode.

The POR flag bit will be set to “1” when POR operation occurs, which will be cleared by a read of the Flags Register. Usually the POR flag bit can be used to check whether an unexpected POR event has taken place.

Software Reset

Reset is down always if “55h” is written to Reset Register. All the internal registers are reset to the default values and the chip will enter the Shut Down Mode.

Shut Down Mode

The WD3153 enters into Shut Down Mode when CHRG is low, and CHIPEN bit (GCR Register) is set to 0 or SCL is pulled to low for over 130ms.

In the Shut Down Mode, the internal registers (except Flags) are reset to the default values and all blocks are turned off. The current consumption is less than 1uA. The I²C interface is accessible, but only Reset and GCR Registers can be configured.

Standby Mode

When CHIPEN bit (GCR Register) is set to “1”, WD3153 enters into Standby Mode.

In the Standby Mode, the needed internal blocks (VBG, UVLO, OSC, OTP etc) are enabled. All the registers can be configured. And the power consumption is about 33uA.

Operating Mode

If LE bit (LCTR Register) is set to “1”, the chip will enter operating mode.

In the operating mode, the power consumption is about 80uA.

Under Voltage Lock Out

The WD3153 has an internal comparator that monitors the voltage of VCC and force the WD3153 into Shut Down Mode if VCC drops to 2.2V. If VCC rises above 2.2V, setting the CHIPEN bit to “1”, the WD3153 will enter into Standby Mode again.

If the UVLO monitor threshold is tripped, the UVLO flag bit is set to “1” in the Flags Register. Upon a read, the Flag register can be cleared.

Over Temperature Protect

IF the WD3153 reaches 135°C, the LED driver block will be disabled, until temperature drops below 120°C, and the OTP flag bit will be set to “1” in the Flags Register, until there is an I²C read of Flags Register.

I²C Interface

Interface Overview

The I²C interface is built in the WD3153. It can be compatible with 1.8V to 5.5V. It provides access to the programmable functions and registers on the device.

This protocol uses a two-wire interface for bidirectional communications between the IC's connected to the bus. The two interface lines are the Serial Data Line (SDA), and the Serial Clock Line (SCL). These lines should be connected to a positive supply, via a pull-up resistor (4.7kΩ) and remain HIGH even when the bus is idle.

Data Transactions

One data bit is transferred during each clock pulse. Data is sampled during the high state of the serial clock (SCL). Consequently, throughout the clock's high period, the data should remain stable. Any changes on the SDA line during the high state of the SCL and in the middle of a transaction, aborts the current transaction. New data should be sent during the low SCL state. This protocol permits a single data line to transfer both command/control information and data using the synchronous serial clock.

Each data transaction is composed of a Start Condition, a number of byte transfers (set by the software) and a Stop Condition to terminate the transaction. Every byte written to the SDA bus must be 8 bits long and is transferred with the most significant bit first. After each byte, an Acknowledge signal must follow. The following sections provide further details of this process.

The Master device on the bus always generates the Start and Stop Conditions (control codes). After a Start Condition is generated, the bus is considered busy and it retains this status until a certain time after a Stop Condition is generated. A high-to-low transition of the data line (SDA) while the clock (SCL) is high indicates a Start Condition. A low-to-high transition of the SDA line while the SCL is high indicates a Stop Condition.

In addition to the first Start Condition, a repeated Start Condition can be generated in the middle of a transaction. This allows another device to be accessed, or a register read cycle.

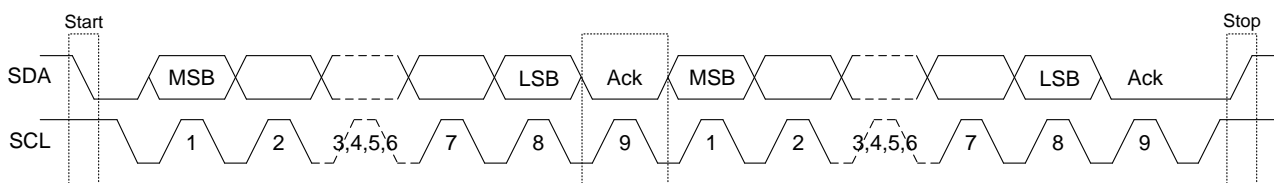

Fig5 I2C data transactions

Addressing Transfer Formats

The WD3153 operates as a slave device with the 7-bit address. If 8-bit address is used for programming, the 8th bit is 1 for read and 0 for write.

Bit7	Bi6	Bit5	Bit4	Bit3	Bit2	Bit1	Bit0
IADR<6>	IADR<5>	IADR<4>	IADR<3>	IADR<2>	IADR<1>	IADR<0>	R/W

Before any data is transmitted, the master transmits the address of the slave being addressed. The slave device should send an acknowledge signal on the SDA line, once it recognizes its address.

The slave address is the first seven bits after a Start Condition. The direction of the data transfer (R/W) depends on the bit sent after the slave address - the eighth bit.

When the slave address is sent, each device in the system compares this slave address with its own. If there is a match, the device considers itself addressed and sends an acknowledge signal. Depending upon the state of the R/W bit (1:read, 0:write), the device acts as a transmitter or a receiver.

The default device address is 45h. The WD3153 allows the user to modify the device address. Through configuration the register IADR (address 77h), the address can be replaced by other values.

Bit7	Bi6	Bit5	Bit4	Bit3	Bit2	Bit1	Bit0
ASEL	DA<6:0>						

When ASEL = 0, device address = 45h (default);

When ASEL = 1, device address = DA<6:0>.

Once the device address is redefined, the master must use the new address. After power-on-reset or soft reset, the device address will be reset to the default value (45h).

Control Register Write Cycle

- ① Master device generates start condition.
- ② Master device sends slave address IADR<6:0> and the data direction bit (R/W=0).
- ③ Slave device sends acknowledge signal if the slave address is correct.
- ④ Master sends control register address (8bits).
- ⑤ Slave sends acknowledge signal.
- ⑥ Master sends data byte to be written to the addressed register (8bits).
- ⑦ Slave sends acknowledge signal.
- ⑧ If master will send further data bytes the control register address will be incremented by one after acknowledge signal.
- ⑨ Write cycle ends when the master creates stop condition.

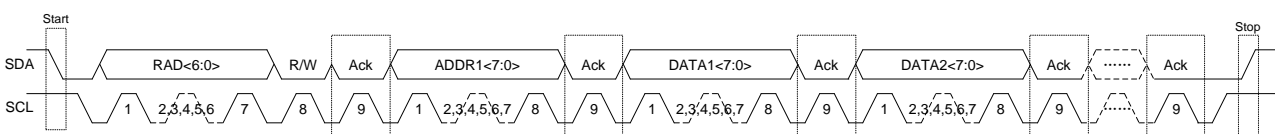

Fig6 I²C Write Cycle

Control Register Read Cycle

- ① Master device generates a start condition. Master device sends slave address IADR<6:0> and the data direction bit (R/W=0).
- ② Slave device sends acknowledge signal if the slave address is correct.
- ③ Master sends control register address (8 bits).
- ④ Slave sends acknowledge signal.
- ⑤ Master device generates repeated start condition.

- ⑥ Master sends the slave address IADR<6:0> and the data direction bit (R/W=1).
- ⑦ Slave sends acknowledge signal if the slave address is correct.
- ⑧ Slave sends data byte from addressed register.
- ⑨ If the master device sends acknowledge signal, the control register address will be incremented by one. Slave device sends data byte from addressed register.
- ⑩ Read cycle ends when the master does not generate acknowledge signal after data byte and generates stop condition.

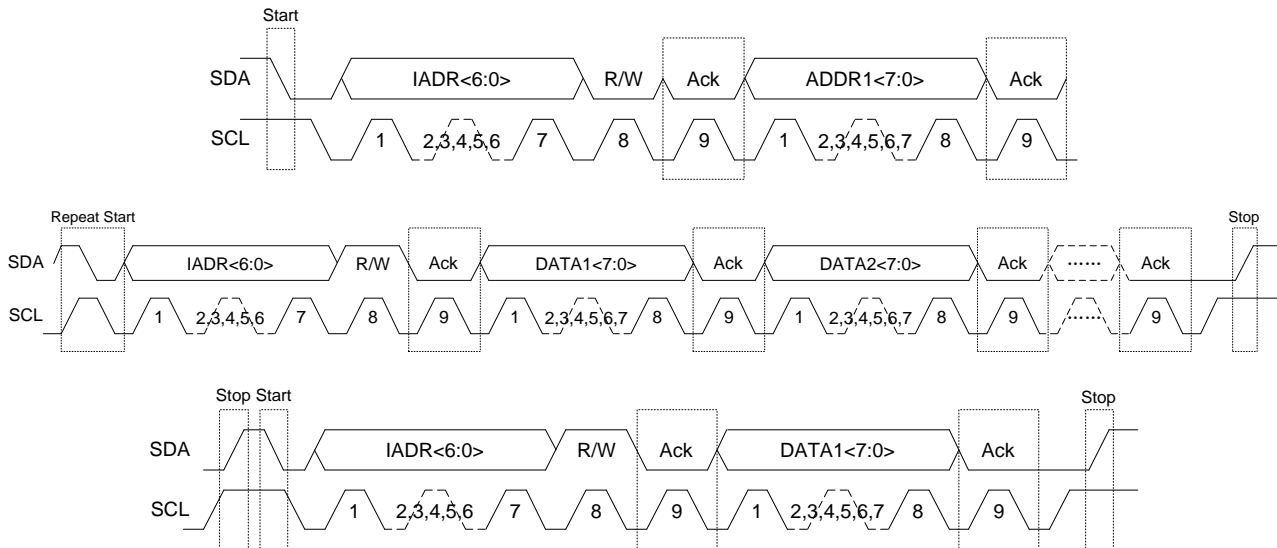

Fig7 I²C Read Cycle

Interrupt

INTN is the interrupt open-drain output pin. It will output low when the following 4 conditions occur:

- a. Power on Reset
- b. The programmable lighting sequence running time duration is complete
- c. Under Voltage Lock Out
- d. Over Temperature Protect

The interrupt function is enabled by the high 5-bits of Register GCR. When the interrupt occurs, the master reads the ISR register to determine the interrupt source. The ISR register is read-only and can be cleared. If no new interrupt is generated, the INTN will output high.

LED Controller

LED Controller Overview

The WD3153 has three independent programmable channels (LED0, LED1, LED2). Trigger connections between channels are common for all channels. All channels have own program memories for storing complex patterns. Brightness control and patterns are done with 8-bit PWM control to get accurate and smooth color control.

Disabled

Each channel can be configured to disabled mode. LED output current will be 0 during this mode.

LED Output Current Setting

LED output current is defined by IMAX bit (Register LCFG0~3).

PWM Setting

Set PWM output value from 0 to 255 by Register PWM0~2.

Direct Control Mode

I²C direct control mode is enabled by the MD bit of Register LCFGx. Changes to the PWM value registers are reflected immediately to the LED brightness.

The WD3153 has fade-in and fade-out function.

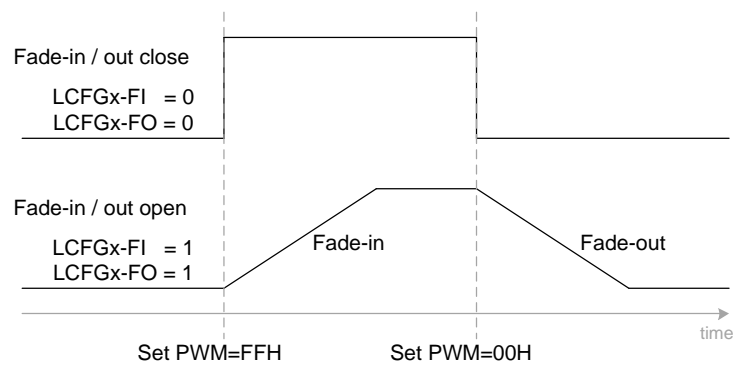

Fig8 Fade-in and Fade-out Function

Program Execution Engines

Use of program execution engines is the other LED output PWM control method available in the WD3153. The device has 3 program execution engines. These engines can be enabled by MD bit of Register LCFGx, and create PWM controlled lighting patterns to the mapped LED outputs according to program codes developed by the user. Program coding is done using programming commands. Programs are loaded into SRAM memory and engine control bits are used to run these programs autonomously. The engines have different operation modes, program execution states, and program counters. Each engine has its own section of the SRAM memory.

The LED pattern is illustrated in the Fig9 below. The cycle is defined with T0~T4 (Fig9). It is possible to program very fast and also very low ramps. The repeat time is defined by REPEAT bits of LEDxT2.

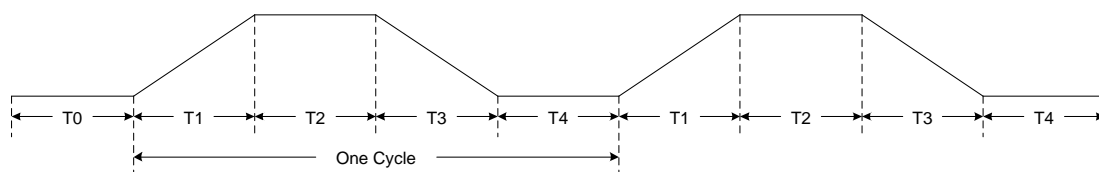

Fig9 LED Lighting Pattern for Program Execution Engines

Auto Charging Indication

In application of mobile phone, when battery voltage is too low and the PMU cannot work, the LED driver cannot be controlled by application processor via I²C interface. In this case, extra LED control circuit is necessary to be built in for charging status indication.

WD3153 provides the auto charging indication function for low battery voltage application. When the external USB power is inserts to phone, the pin CHRG is pulled high, WD3153 will enter active state automatically. The predefined pattern output only on pin LED0, the LED1 and LED2 keep off status. The pattern parameter is showed in fig10. The maximum current is 5mA, breathing period is about 5s or continuous, which is set by SET pin (SET=L, period is 5s; SET=H, continuous). Once the CHRG pin goes low, the device comes back to Shut Down state again and stops LED0 output.

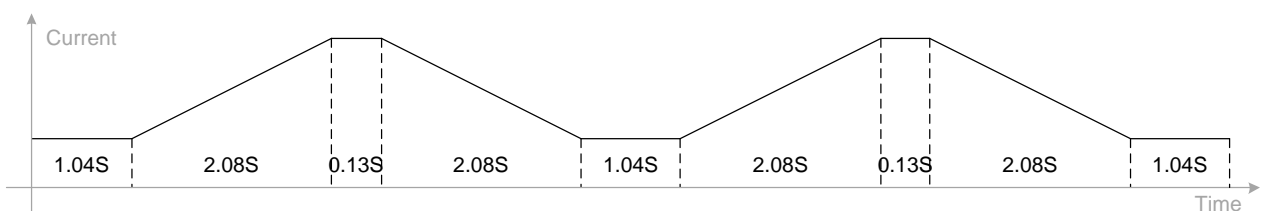

Fig10 Auto Charging Indication Pattern Parameter

The auto charging indication function should be closed by configured FCTR register CHRG_EN bit to 1 when the processor is able to configure WD3153 via I²C interface, then the lighting effects will have no relation with the CHRG status.

When special charger IC is used and pin CHRG is recommend to be connected to status pin of charger IC (Fig1), the pin LED0 of WD3153 can indicate the real battery charging status.

When no charger IC is applied, and battery charging is managed by PMU (Fig2), no real charging status signal can be adapted, so the LED0 status can only indicate whether the USB power is plugged in or not.

When the pull-up resistance is 30KΩ, VBUS range can be 5V ~ 15V.

Synchronously Lighting

In Real Color Breathing Lighting application, the SYN_EN (Register LEDSYN) should be set to 1. The three LED channels will lighting synchronously. The color can be set by IMAX (Register LCFG0~3) and PWM duty (Register PWM0~2).

Register Definition

Register List

Addr (HEX)	Register	Function
00	Chip ID and Software Reset Register	Chip ID and Reset all registers
01	Operation Enable Register	Chip enable and interrupt enable
02	Interrupt Register	Interrupt status
03	Function Control Register	Function enable
30	Channel Enable Register	Channel enable
31~33	Lighting Mode Register	LED0~LED2 lighting mode
34~36	PWM Control Register	PWM value of LED0~2
37/3A/3D	T1 & T2 Setting Register	T1 & T2 setting
38/3B/3E	T3 & T4 Setting Register	T3 & T4 setting
39/3C/3F	T0 & Repeat time Setting Register	T0 & repeat time setting
77	Redefined ID Register	Redefined ID

Register Maps

Addr	Register	Type	Bit7	Bit6	Bit5	Bit4	Bit3	Bit2	Bit1	Bit0	
00h	RSTR	WR	0	0	1	1	0	0	1	1	
01h	GCR	WR	LIE2	LIE1	LIE0	UVLO_IE	OTP_IE	Reserved		CHIPEN	
02h	ISR	R	LIS2	LIS1	LIS0	PUIS	UVLO_IS	OTP_IS	Reserved		
03h	FCTR	WR	Reserved			OTP_EN	UVLO_EN	CHRG_EN	PWM_HF	LOG_EN	
30h	LCTR	WR	Reserved					LE2	LE1	LE0	
31h	LCFG0	WR	0	FO	FI	MD	0	IMAX			
32h	LCFG1	WR	0	FO	FI	MD	0	IMAX			
33h	LCFG2	WR	0	FO	FI	MD	0	IMAX			
34h	PWM0	WR	PWM								
35h	PWM1	WR	PWM								
36h	PWM2	WR	PWM								
37h	LED0T0	WR	0	T1			0	T2			
38h	LED0T1	WR	0	T3			0	T4			
39h	LED0T2	WR	T0				REPEAT				
3Ah	LED1T0	WR	0	T1			0	T2			
3Bh	LED1T1	WR	0	T3			0	T4			
3Ch	LED1T2	WR	T0				REPEAT				
3Dh	LED2T0	WR	0	T1			0	T2			
3Eh	LED2T1	WR	0	T3			0	T4			
3Fh	LED2T2	WR	T0				REPEAT				
4Ah	LEDSYN	WR	Reserved					SYN_EN	Reserved		
77h	IADR	WR	ASEL	DA[6:0]							

Register Description

Chip ID and Software Reset Register RSTR

Address: 00h

Default value: 33h

Bit7	Bi6	Bit5	Bit4	Bit3	Bit2	Bit1	Bit0
RST<7>	RST<6>	RST<5>	RST<4>	RST<3>	RST<2>	RST<1>	RST<0>

Description:

Symbol	Bit	Type	Active	Description
RST<7:0>	7:0	WR		Chip ID: 33h Reset: write 55h to RSTR, reset logic and all registers.

Global Control Register GCR

Address: 01h

Default value: 00h

Bit7	Bi6	Bit5	Bit4	Bit3	Bit2	Bit1	Bit0
LIE2	LIE1	LIE0	UVLO_IE	OTP_IE	Reserved		CHIPEN

Description:

Symbol	Bit	Type	Active	Description
LIE2	7	WR	High	LED2 interrupt enable
LIE1	6	WR	High	LED1 interrupt enable
LIE0	5	WR	High	LED0 interrupt enable
UVLO_IE	4	WR	High	UVLO interrupt enable
OTP_IE	3	WR	High	OTP interrupt enable
Reserved	2:1	WR		
ENABLE	0	WR	High	Chip enable.

Interrupt Register ISR

Address: 02h

Default value: 00h

Bit7	Bi6	Bit5	Bit4	Bit3	Bit2	Bit1	Bit0
LIS2	LIS1	LIS0	PUIS	UVLO_IS	OTP_IS	Reserved	

Description:

Symbol	Bit	Type	Active	Description
LIS2	7	WR	High	LED2 interrupt status (0: no interrupt; 1: interrupt)
LIS1	6	WR	High	LED1 interrupt status (0: no interrupt; 1: interrupt)
LIS0	5	WR	High	LED0 interrupt status (0: no interrupt; 1: interrupt)
PUIS	4	WR	High	Power on reset interrupt.
UVLO_IS	3	R	High	UVLO interrupt status (1: under voltage)
OTP_IS	2	R	High	OTP interrupt status (1: over temperature)
Reserved	1:0	WR		

Function Control Register FCTR

Address: 03h

Default value: 11h

Bit7	Bi6	Bit5	Bit4	Bit3	Bit2	Bit1	Bit0
Reserved			OTP_EN	UVLO_EN	CHRG_EN	PWM_HF	LOG_EN

Description:

Symbol	Bit	Type	Active	Description
Reserved	7:5	WR		
OTP_EN	4	WR	High	Over Temperature Protection enable
UVLO_EN	3	WR	High	Under Voltage Lock Out enable
CHRG_EN	2	WR	Low	Charge function enable
PWM_HF	1	WR		PWM Frequency Shift (0: 250Hz; 1: 500Hz)
LOG_EN	0	WR	High	Log and Linear Shift (0: linear; 1: Log)

LED Control Register LCTR

Address: 30h

Default value: 00h

Bit7	Bi6	Bit5	Bit4	Bit3	Bit2	Bit1	Bit0
Reserved					LE2	LE1	LE0

Description:

Symbol	Bit	Type	Active	Description
Reserved	7:3	WR		
LE2	2	WR	High	LED2 enable.
LE1	1	WR	High	LED1 enable.
LE0	0	WR	High	LED0 enable.

Lighting Mode Register LCFG0~2

Address: 31~33h

Default value: 00h

Bit7	Bi6	Bit5	Bit4	Bit3	Bit2	Bit1	Bit0
0	FO	FI	MD	0	IMAX		

Description:

Symbol	Bit	Type	Active	Description
FO	6	WR	High	Fade-out enable 1: Fade-out time = T3 0: Disable. This function is enabled during Direct Control Mode
FI	5	WR	High	Fade-in enable 1: Fade-in time = T1 0: Disable This function is enabled during Direct Control Mode

MD	4	WR	High	Lighting mode control 0: Direct Control Mode 1: Programmable Lighting Mode
IMAX	2:0	WR		Output current setting 000: 0mA (default) 001: 5mA 010: 10mA 011: 15mA 1xx: 25mA

PWM Control Register PWM0~2

Address: 34~36h

Default value: 00h

Bit7	Bi6	Bit5	Bit4	Bit3	Bit2	Bit1	Bit0
PWM<7:0>							

Description:

Symbol	Bit	Type	Active	Description
PWM	7:0	WR		Output PWM value setting 0: no PWM 255: 100% duty

T1 & T2 Setting Register LEDi0

Address: 37h, 3Ah, 3Dh

Default value: 00h

Bit7	Bi6	Bit5	Bit4	Bit3	Bit2	Bit1	Bit0
0	T1			0	T2		

Description:

Symbol	Bit	Type	Active	Description
T1	6:4	WR		Fade-in time setting 000: 0.13s 001: 0.26s 010: 0.52s 011: 1.04s 100: 2.08s 101: 4.16s 110: 8.32s 111: 16.64s
T2	2:0	WR		Hold time setting after fade-in 000: 0.13s 001: 0.26s 010: 0.52s 011: 1.04s 100: 2.08s 101: 4.16s Others: 4.16s

T3 & T4 Setting Register LEDi1

Address: 38h, 3Bh, 3Eh

Default value: 00h

Bit7	Bit6	Bit5	Bit4	Bit3	Bit2	Bit1	Bit0
0	T3			0	T4		

Description:

Symbol	Bit	Type	Active	Description
T3	6:4	WR		Fade-out time setting 000: 0.13s 001: 0.26s 010: 0.52s 011: 1.04s 100: 2.08s 101: 4.16s 110: 8.32s 111: 16.64s
T4	2:0	WR		Hold time setting after fade-out 000: 0.13s 001: 0.26s 010: 0.52s 011: 1.04s 100: 2.08s 101: 4.16s 110: 8.32s 111: 16.64s

T0 & Repeat time Setting Register LEDi2

Address: 39h, 3Ch, 3Fh

Default value: 00h

Bit7	Bit6	Bit5	Bit4	Bit3	Bit2	Bit1	Bit0
T0				REPEAT			

Description:

Symbol	Bit	Type	Active	Description
T0	7:4	WR		Delay time setting before auto blinking 000: 0s 001: 0.13s 010: 0.26s 011: 0.52s 100: 1.04s 101: 2.08s 110: 4.16s 111: 8.32s 1000: 16.64s Others: 16.64s
REPEAT	3:0	WR		Blinking times setting 0000: Continuous blinking 0001: 1 time 0010: 2 times 1111: 15 times

Synchronously Lighting Register LEDSYN

Address: 4Ah

Default value: 00h

Bit7	Bi6	Bit5	Bit4	Bit3	Bit2	Bit1	Bit0
Reserved					SYN_EN	Reserved	

Description:

Symbol	Bit	Type	Active	Description
Reserved	7:3	WR		
SYN_EN	2	WR	High	Synchronously Lighting enable
Reserved	1:0	WR		

Redefined ID Register IADR

Address: 77h

Default value: 45h

Bit7	Bi6	Bit5	Bit4	Bit3	Bit2	Bit1	Bit0
ASEL	DA<6:0>						

Description:

Symbol	Bit	Type	Active	Description
ASEL	7	WR	High	ID select: 0: ID 45h (default) 1: ID DA[6:0]
DA<6:0>	6:0	WR		Redefined ID only if ASEL=1

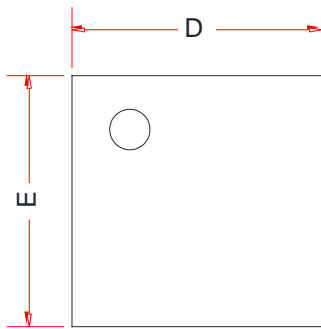
PACKAGE OUTLINE DIMENSIONS
DFN2x2-10L

TOP VIEW

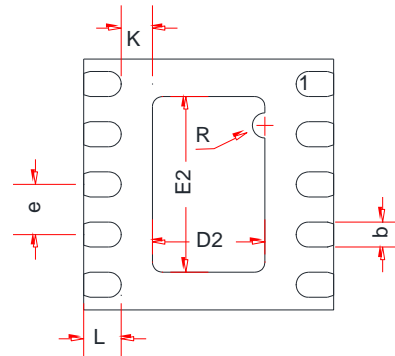

BOTTOM VIEW

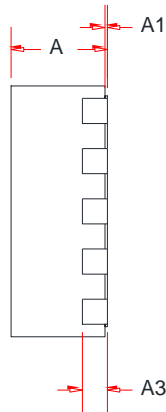

SIDE VIEW

Symbol	Dimensions in Millimeters		
	Min.	Typ.	Max.
A	0.70	0.75	0.80
A1	0.00	0.02	0.05
A3	0.20 Ref.		
b	0.15	0.20	0.25
D	1.90	2.00	2.10
E	1.90	2.00	2.10
D2	0.80	0.90	1.00
E2	1.30	1.40	1.50
e	0.30	0.40	0.50
K	0.15	0.25	0.35
L	0.25	0.30	0.35
R	0.10 Ref.		

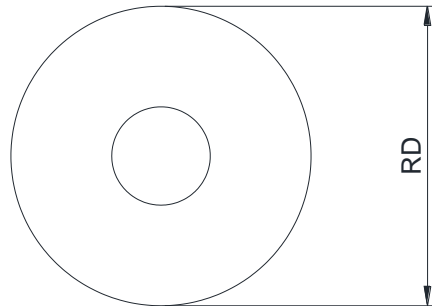
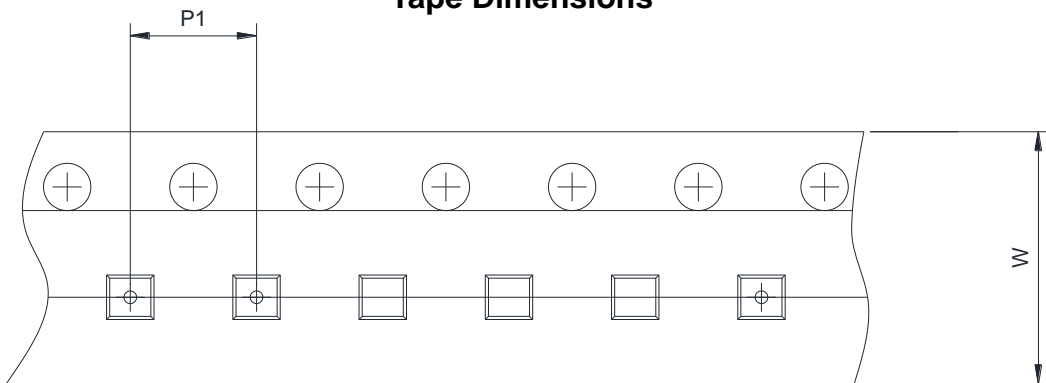
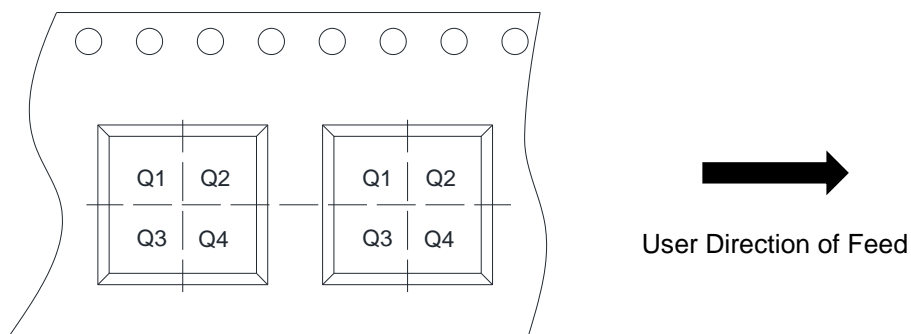
TAPE AND REEL INFORMATION
Reel Dimensions

Tape Dimensions

Quadrant Assignments For PIN1 Orientation In Tape

RD	Reel Dimension	<input checked="" type="checkbox"/> 7inch <input type="checkbox"/> 13inch
W	Overall width of the carrier tape	<input checked="" type="checkbox"/> 8mm <input type="checkbox"/> 12mm <input type="checkbox"/> 16mm
P1	Pitch between successive cavity centers	<input type="checkbox"/> 2mm <input checked="" type="checkbox"/> 4mm <input type="checkbox"/> 8mm
Pin1	Pin1 Quadrant	<input checked="" type="checkbox"/> Q1 <input type="checkbox"/> Q2 <input type="checkbox"/> Q3 <input type="checkbox"/> Q4

X-ON Electronics

Largest Supplier of Electrical and Electronic Components

Click to view similar products for [LED Display Drivers](#) category:

Click to view products by [Will Semiconductor](#) manufacturer:

Other Similar products are found below :

[MAP9000QNRH](#) [AP5726WUG-7](#) [AL8806QMP-13](#) [AP5726FDCG-7](#) [AS3693B-ZTQT](#) [AP5725WUG-7](#) [MAX139EQH+D](#) [STP16DP05PTR](#)
[STP16CPP05PTR](#) [STP16CPP05XTTR](#) [LV5236VZ-TLM-H](#) [BP9911CC](#) [ZXLD1366QEN8TC](#) [MT7725D](#) [TX6143](#) [SY6813PEC](#) [SD1002L4](#)
[AW3643CSR](#) [MP3370GN-Z](#) [LA2284L-G09-T](#) [SEDA](#) [SCT2027CSSG](#) [LYT3315D](#) [LYT3324D](#) [LYT4211E2](#) [LYT4214E2](#) [LYT4215E2](#)
[LYT4217E2](#) [LYT4218E2](#) [LYT4222E](#) [LYT4317E2](#) [LYT4321E](#) [LYT4323E](#) [LYT4324E3](#) [LYT4326E3](#) [TPS92020DR](#) [TPS92691PWPR](#)
[BCR420U](#) [HV9801ALG-G](#) [IS31FL3199-QFLS2-TR](#) [IS31FL3731-QFLS2-TR](#) [CAT4238TD](#) [SCT2001ASIG](#) [SCT2024CSTG](#) [SCT2167CSOG](#)
[SCT2167CSSG](#) [STP16CPPS05XTTR](#) [TLE4241GMFUMA1](#) [ICM7212MIQH+D](#) [ICM7212AIQH+D](#)