

# WS3221C

**Over-Voltage-Protection load switch with Adjustable OVLO threshold**

[Http://www.willsemi.com](http://www.willsemi.com)

### Descriptions

The WS3221 is an Over-Voltage-Protection (OVP) load switch with adjustable OVLO threshold voltage. The device will switch off internal MOSFET to disconnect IN to OUT to protect load when any of input voltage over the threshold.

When the OVLO input set below the external OVLO select voltage, the WS3221 automatically chooses the internal fixed OVLO threshold voltage. The over voltage protection threshold voltage can be adjusted with external resistor divider and the OVLO threshold voltage range is 4~20V. The Over temperature protection (OTP) function monitors chip temperature to protect the device.

The WS3221 is available in standard CSP-6L Package. Standard products are Pb-free and Halogen-free.

### Features

- Maximum input voltage : 29V
- Switch ON resistance : 28mΩ Typ.
- Ultra fast OVP response time : 50ns Typ.
- OVLO threshold voltage

Reference voltage for adjustable version

1.2V : WS3221C with ±2.5% accuracy

Internal threshold voltage for fixed version

6.8V : WS3221C68 with ±2% accuracy

10.5V : WS3221CB with ±2% accuracy

14.0V : WS3221CE with ±2% accuracy

### Applications

- Mobile Handsets and Tablets
- Portable Media Players
- Peripherals

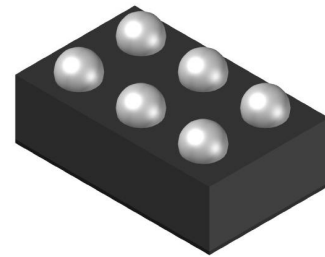

**CSP-6L (Bottom View)**

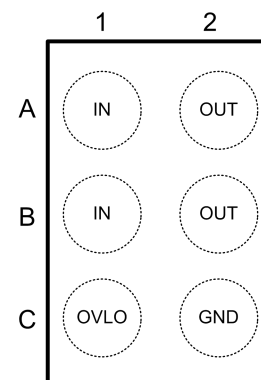

**Pin configuration (Top view)**

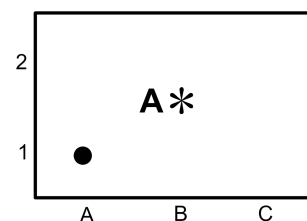

### Marking

**A** = Device code

**\*** = Month code (A~Z)

### Order information

Device	Marking	Package	Shipping
WS3221C-6/TR	A*	CSP-6L	3000/Reel&Tape
WS3221C68-6/TR	F*	CSP-6L	3000/Reel&Tape
WS3221CB-6/TR	B*	CSP-6L	3000/Reel&Tape
WS3221CE-6/TR	E*	CSP-6L	3000/Reel&Tape

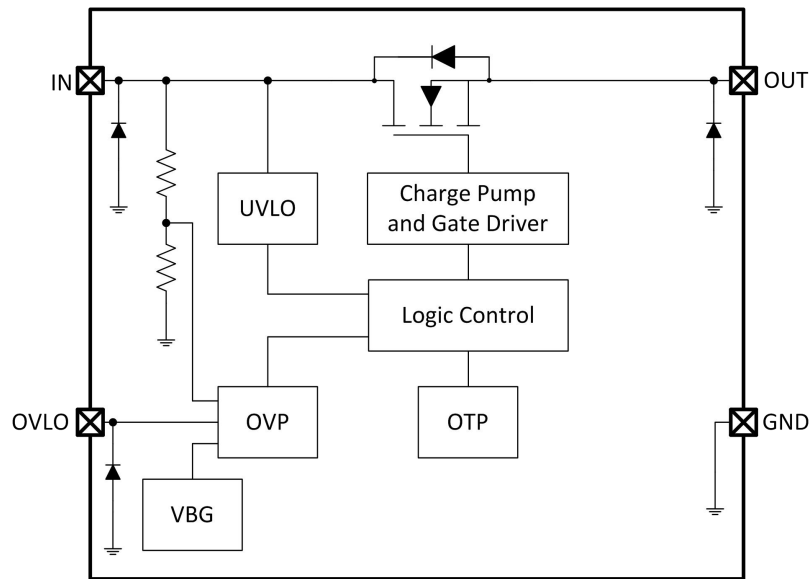
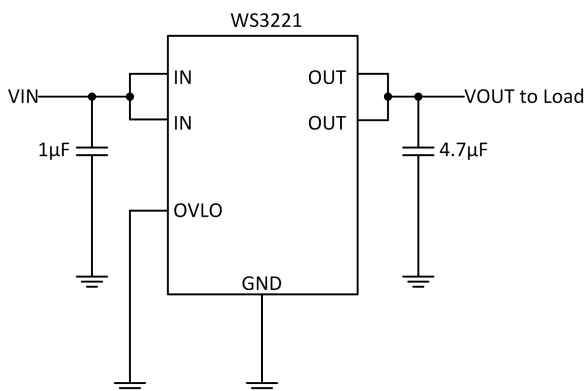
**Function Block Diagram**

**Typical Applications**

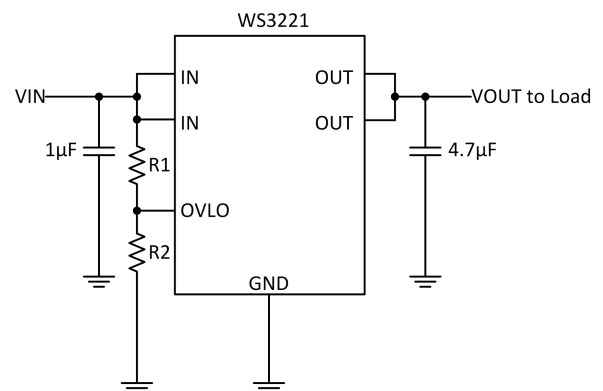
Over Voltage Protect with Internal OVLO Threshold Setting



Over Voltage Protect with External OVLO Threshold Setting

**Note1:** R1 and R2 are only required for External OVP, otherwise connect OVLO to GND

**Note2:** Recommend  $10K \leq R2 \leq 50K$

**Pin Descriptions**

Pin No.	Symbol	Descriptions
A1, B1	IN	Switch Input and Device Power Supply.
A2, B2	OUT	Switch Output to Load.
C1	OVLO	External OVLO adjustment. Connect a resistor-divider to set different OVLO threshold, $V_{OVLO} = 1.2 \times (1 + R1/R2)$ as shown typical application diagram. Connect OVLO to GND when using the internal fixed threshold voltage.
C2	GND	Ground

**Absolute Maximum Ratings**

Parameter	Symbol	Value	Unit
Input voltage (IN pin)	$V_{IN}$	-0.3 ~ 29	V
Output voltage (OUT pin)	$V_{OUT}$	-0.3 ~ 22	V
Input voltage (OVLO pin)	$V_{OVLO}$	-0.3~15	V
MAX Continuous Output current	$I_{OUT}$	4	A
Switch FET Body Diode Continuous Current	$I_{DIODE}$	2.5	A
Body Diode Forward Peak Pulse Current*1	$I_{PP}$	Pulse Width=10ms	20
		Pulse Width=20μs	50
Thermal resistance	$R_{\theta JA}$	98	°C/W
Junction temperature	$T_J$	150	°C
Lead temperature(10s)	$T_L$	260	°C
Storage temperature	$T_{stg}$	-55 ~ 150	°C
ESD Ratings	HBM	±4000	V
	MM	±200	V

**\*1 Single Pulse**

These are stress ratings only. Stresses exceeding the range specified under “Absolute Maximum Ratings” may cause substantial damage to the device. Functional operation of this device at other conditions beyond those listed in the specification is not implied and prolonged exposure to extreme conditions may affect device reliability.

**Recommend Operating Conditions (Ta=25°C, unless otherwise noted)**

Parameter	Symbol	Value	Unit
Input voltage	$V_{IN}$	2.5 ~ 28	V
Ambient operating temperature	$T_{opr}$	-40 ~ 85	°C

**Electronics Characteristics** ( $V_{IN}=5V$ ,  $C_{IN}=1\mu F$ ,  $C_{OUT}=4.7\mu F$ ,  $T_a=25^\circ C$ , unless otherwise noted)

Parameter	Symbol	Conditions	Min.	Typ.	Max.	Units
Input voltage range	$V_{IN}$		2.5		28	V
Quiescent current	$I_Q$	NO Load		110		$\mu A$
ON resistance	$R_{ON}$	$V_{IN}=5V$ , $I_{OUT}=1A$		28	35	$m\Omega$
OVP response time	$t_{OVP}$	$V_{IN}$ rising, $C_{IN}=C_L=0pF$ *1		50		ns
OVP threshold voltage	$V_{OVLO\_TH}$	WS3221C, $V_{OVLO\_TH}$	1.17	1.2	1.23	V
		adj. version $V_{OVLO\_HYS}$ *2		35		mV
		WS3221C68, fixed version	6.66	6.8	6.93	V
		WS3221CB, fixed version	10.29	10.5	10.71	V
		WS3221CE, fixed version	13.58	14.0	14.42	V
Adjust OVP voltage range	$V_{OVLO\_RANGE}$	$V_{IN}$ rising	4		20	V
External OVLO select Threshold	$V_{OVLO\_SELECT}$		0.2		0.3	V
UVLO threshold voltage	$V_{UVLO}$	$V_{IN}$ rising		2.3		V
UVLO hysteresis voltage	$V_{UVLO\_HYS}$	$V_{IN}$ falling		0.25		V
Turn ON time	$T_{ON}$	$V_{IN}>UVLO$ to $V_{OUT}=V_{IN}*90\%$ $C_L=0$		16		ms
Output discharge resistance	$R_{DCHG}$	$V_{IN}=5V$		220		$\Omega$
OTP threshold temperature	$T_{OTP}$	$V_{IN}=5V$		150		$^\circ C$
OTP hysteresis temperature	$T_{HYS}$	$V_{IN}=5V$		20		$^\circ C$

\*1: Guaranteed by design

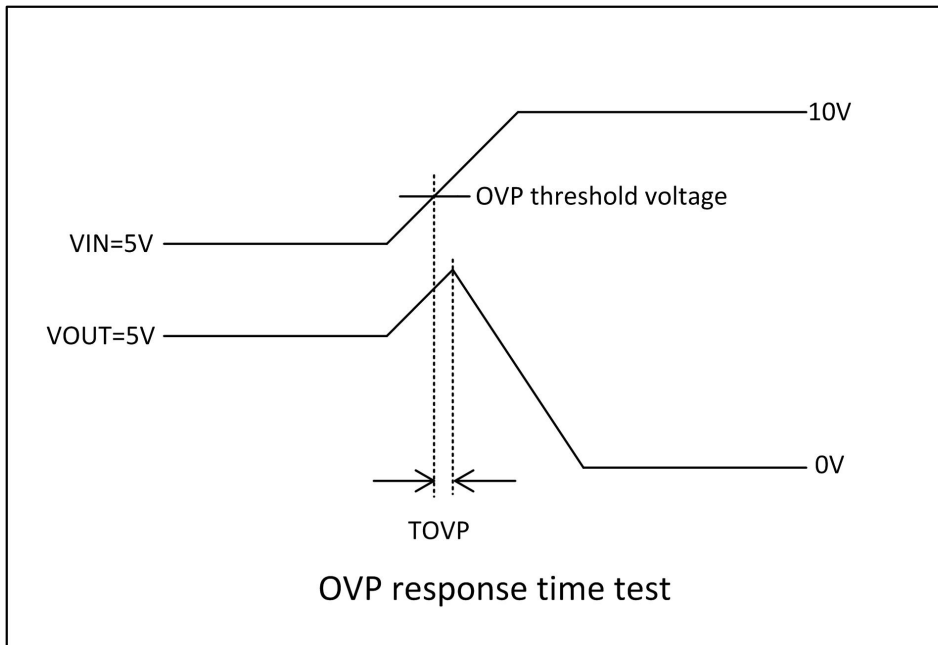

\*2: If connect a resistor-divider to set different OVLO threshold, then  $V_{OVLO\_HYS} = 35 \times (1+R1/R2)$  mV

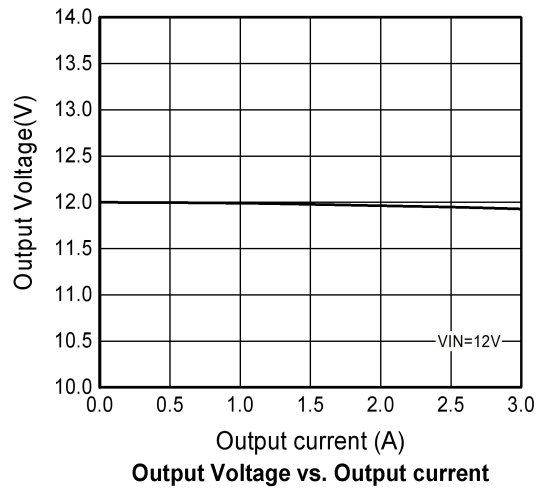
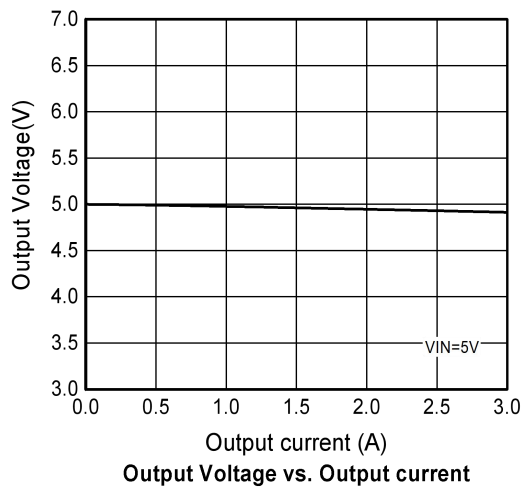
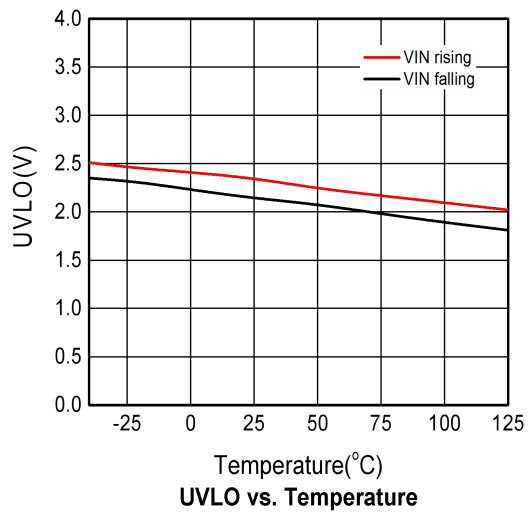
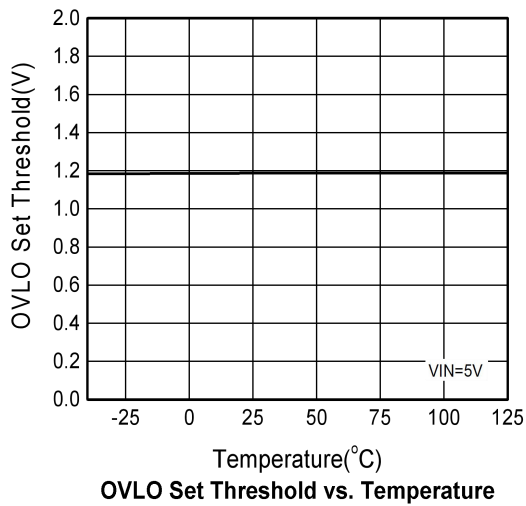
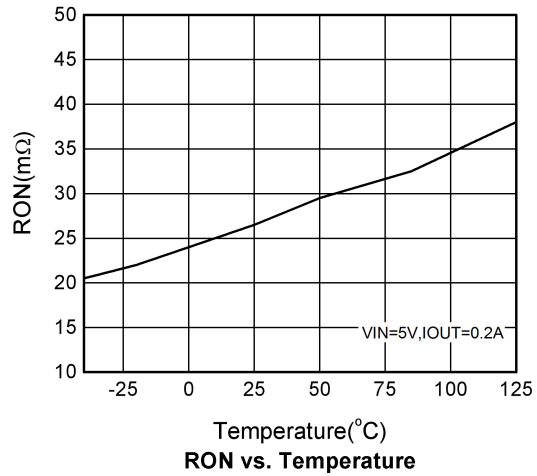
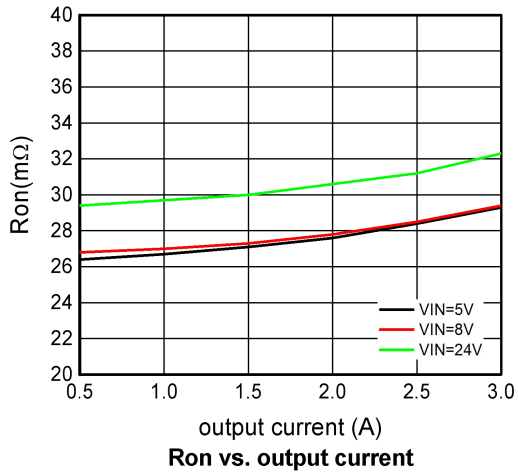
**Typical Characteristics ( $T_A=25^{\circ}\text{C}$ , unless otherwise noted)**

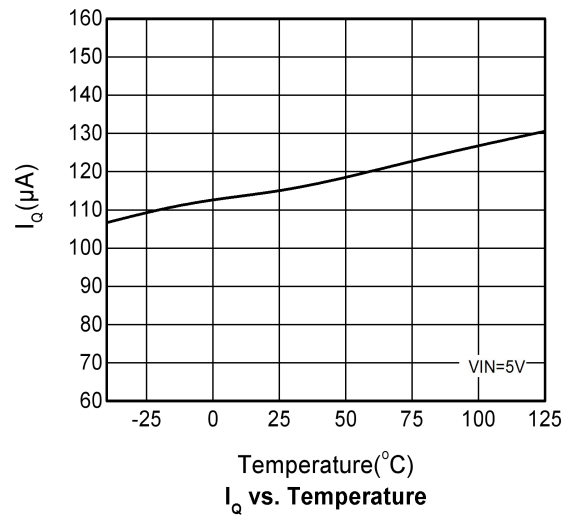
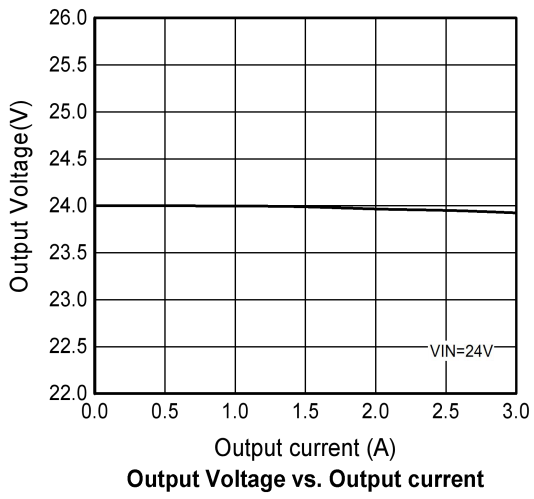

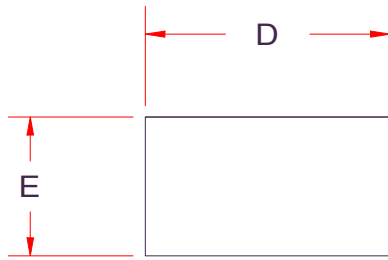
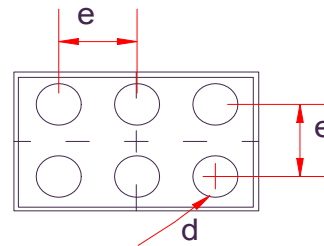
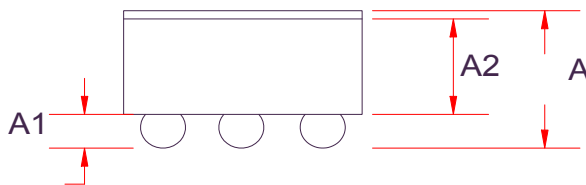
**PACKAGE OUTLINE DIMENSIONS**
**CSP-6L**

**TOP VIEW**

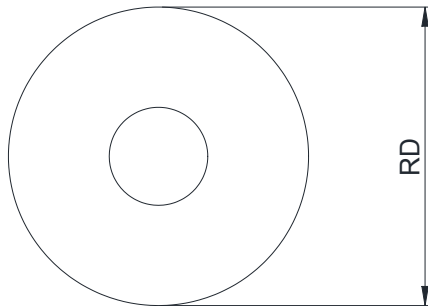
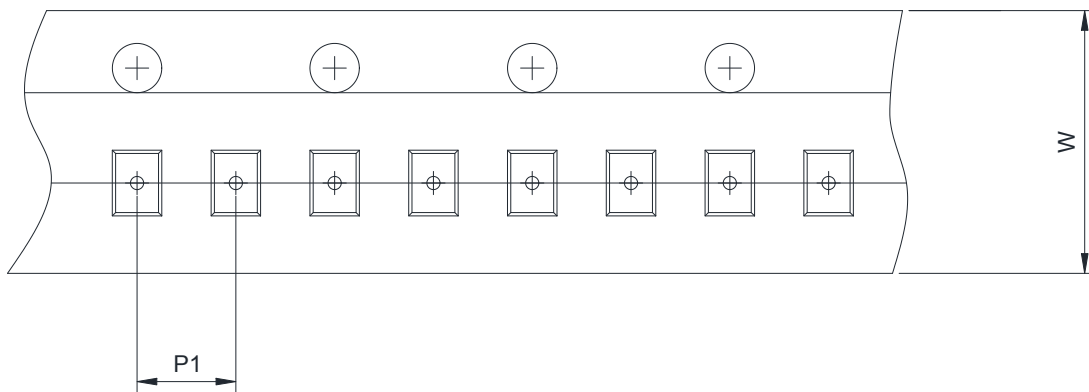
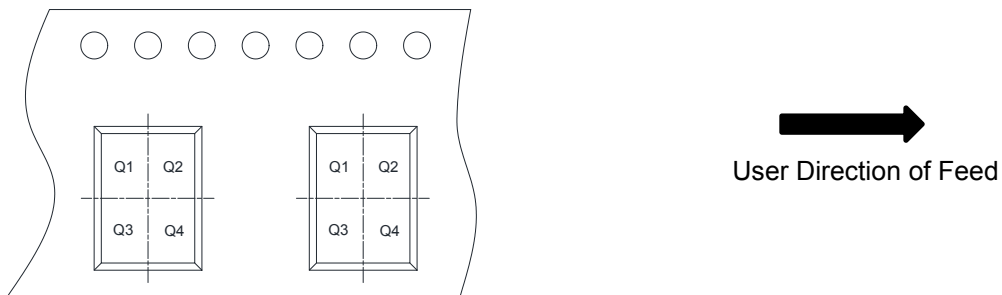
**BOTTOM VIEW**

**SIDE VIEW**

Symbol	Dimensions in Millimeters		
	Min.	Typ.	Max.
A	0.52	0.57	0.63
A1	0.16	0.19	0.22
A2	0.33	0.36	0.39
D	1.22	1.25	1.28
E	0.74	0.77	0.80
e	0.40Typ.		
e1	0.40Typ.		
d	0.19	0.23	0.27

**TAPE AND REEL INFORMATION**
**Reel Dimensions**

**Tape Dimensions**

**Quadrant Assignments For PIN1 Orientation In Tape**

RD	Reel Dimension	<input checked="" type="checkbox"/> 7inch	<input type="checkbox"/> 13inch
W	Overall width of the carrier tape	<input checked="" type="checkbox"/> 8mm	<input type="checkbox"/> 12mm <input type="checkbox"/> 16mm
P1	Pitch between successive cavity centers	<input type="checkbox"/> 2mm	<input checked="" type="checkbox"/> 4mm <input type="checkbox"/> 8mm
Pin1	Pin1 Quadrant	<input checked="" type="checkbox"/> Q1	<input type="checkbox"/> Q2 <input type="checkbox"/> Q3 <input type="checkbox"/> Q4



## X-ON Electronics

Largest Supplier of Electrical and Electronic Components

*Click to view similar products for [Battery Management](#) category:*

*Click to view products by [Will Semiconductor](#) manufacturer:*

Other Similar products are found below :

[NCP1851BFCCT1G](#) [NCP1855FCCT1G](#) [FAN54063UCX](#) [MP2615GQ-P](#) [LC05132C01NMTTTG](#) [ISL95522HRZ](#) [BD8665GW-E2](#)  
[ISL95522AIRZ](#) [S-82D1AAE-A8T2U7](#) [S-82D1AAA-A8T2U7](#) [S-8224ABA-I8T1U](#) [MP2615CGQ-P](#) [ISL6251HRZ](#) [ISL6253HRZ](#) [ISL6292-2CR3](#) [ISL6292BCRZ-T](#) [ISL6299AIRZ](#) [ISL9211AIRU58XZ-T](#) [ISL9214IRZ](#) [ISL9220IRTZ-T](#) [FAN54161UCX](#) [DW01-A/J](#) [DW01A](#) [4056H](#)  
[4056D](#) [TP4056](#) [TP4054](#) [TP4057](#) [IP2326\\_NPD](#) [IP2709\\_BF20WP](#) [TP4057](#) [TP4054](#) [TP4056-MS](#) [TP4057-MS](#) [TP4054-MS](#) [SY6982CQDC](#)  
[SLM6335](#) [SLM6500S](#) [TP4057](#) [DW01](#) [AP5056HSPER](#) [EG4321](#) [GN4054B](#) [GN4054A](#) [HG4054M5/TR](#) [4060](#) [4061](#) [4061H](#) [4056A](#) [4056V](#)