

WS3235

Over Voltage Protection IC with Precision Adjustable Current Limit

[Http://www.omnivision-group.com](http://www.omnivision-group.com)

Descriptions

The WS3235 features Input and Battery Over Voltage Protection as well as precision adjustable output Current Limit.

When input voltage exceeds input OVP threshold, the WS3235 will turn off internal MOSFET to disconnect IN to OUT. Current limit threshold can be programmed by external resistor. When OCP occurs and lasts for more than 180µs blanking time, the MOSFET will turn off. Once OCP reaches 16 times, the MOSFET will be permanently off unless the input power is recycled or \overline{EN} pin re-enabled. Battery OVP threshold is fixed 4.35V, and built-in 180µs blanking time could prevent false triggering. When the battery OVP occurs for 16 times, the MOSFET will turn off permanently unless the input power is recycled or \overline{EN} pin re-enabled.

The WS3235 is available in DFN2x2-8L package. Standard product is Pb-Free and Halogen-Free.

Features

- Programmable OCP
- Fixed OVP Threshold
 - WS3235D : 6.8V
 - WS3235D58 : 5.85V
 - WS3235D62 : 6.25V
- Battery OVP : 4.35V
- Maximum Input Voltage: 30V
- Input Over Voltage Turn Off Time: 0.1µs
- Over Temperature Protection
- High Immunity of False Triggering Under Transients
- High Accuracy Protection Thresholds
- Warning Indication Output

Applications

- Cellular Phones and Digital Cameras
- PDAs and Smart Phones
- Portable Instruments

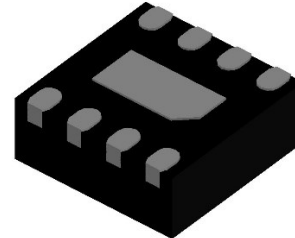

DFN2x2-8L (Bottom View)

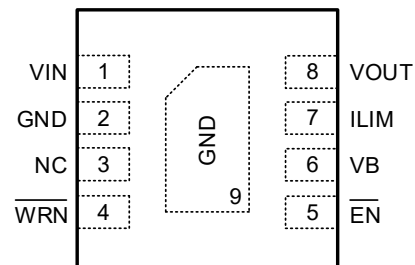

Pin Configuration (Top view)

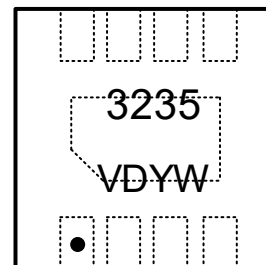

3235 = Device code
 VD = Special code
 Y = Year code
 W = Week code

Marking

Order Information

Device	Package	Shipping
WS3235D-8/TR	DFN2x2-8L	3000/Reel & Tape
WS3235D58-8/TR	DFN2x2-8L	3000/Reel & Tape
WS3235D62-8/TR	DFN2x2-8L	3000/Reel & Tape

Typical Application Circuit

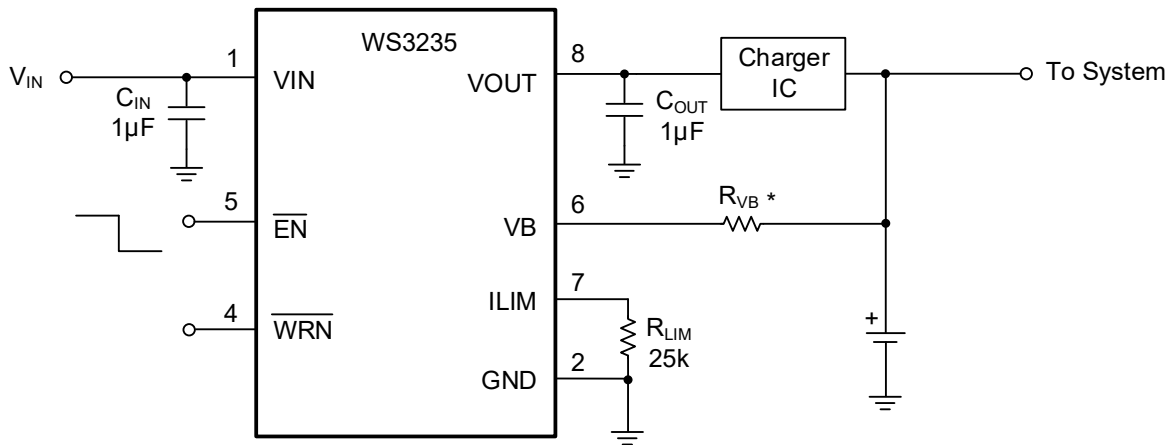

* The recommended value of R_{VB} is 10k Ω ~200k Ω .

Pin Descriptions

Pin No.	Symbol	Descriptions
1	VIN	The input power source. The VIN can withstand up to 30V input.
2	GND	Analog Ground.
3	NC	No Internal Connection.
4	\overline{WRN}	This is an open-drain logic output that turns LOW when any protection event occurs.
5	\overline{EN}	Chip Enable (Active Low). Pull this pin to low or leave it floating to enable the IC and force it to high to disable the IC.
6	VB	Battery voltage monitoring input. This pin is connected to the battery pack positive terminal via an isolation resistor.
7	ILIM	Over current protection threshold setting pin. Connect a resistor between this pin and GND to set the OCP threshold.
8	VOUT	Output through the power MOSFET.
9 (Exposed Pad)	GND	The exposed pad must be soldered to a large PCB and connected to GND for maximum thermal dissipation.

Function Block Diagram

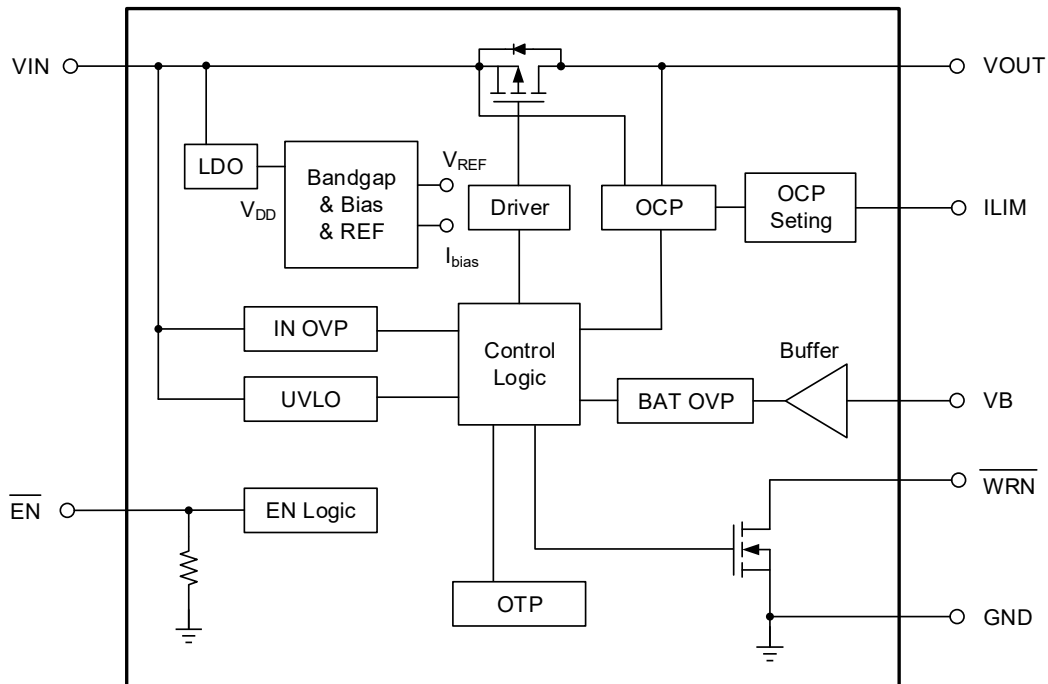

Absolute Maximum Ratings

Parameter	Symbol	Value	Unit
VIN pin voltage range	V _{IN}	-0.3 ~ 30	V
VOUT pin voltage range	V _{OUT}	-0.3 ~ 15	V
VB pin voltage range	V _B	-0.3 ~ 15	V
Other pins voltage range	—	-0.3 ~ 6	V
Package Thermal Resistance- DFN2x2-8L (Note 1)	Junction to Ambient Thermal Resistance	R _{θJA}	90
	Junction to Case Thermal Resistance	R _{θJC}	15
Junction temperature	T _J	150	°C
Lead temperature (Soldering, 10sec.)	T _L	260	°C
Operation temperature	T _{opr}	-40 ~ 85	°C
Storage temperature	T _{stg}	-65 ~ 150	°C
ESD ratings	HBM	4000	V
	CDM	2000	V
	MM	200	V

These are stress ratings only. Stresses exceeding the range specified under “Absolute Maximum Ratings” may cause substantial damage to the device. Functional operation of this device at other conditions beyond those listed in the specification is not implied and prolonged exposure to extreme conditions may affect device reliability.

Note 1: Thermal Resistance is measured with the component mounted on 1.5inch x 1.5inch, 2layers, FR4 test board with 1.0inch x 1.0inch copper area of 2oz in top layer, and in still air condition.

Electronics Characteristics

 ($V_{IN}=5V$, $C_{IN}=1\mu F$, $C_{OUT}=1\mu F$, $T_A=25^\circ C$, unless otherwise noted)

Parameter	Symbol	Test Condition	Min	Typ	Max	Unit
Power On Reset						
Operation Voltage Range	V_{IN}	WS3235D	3		6.55	V
		WS3235D58	3		5.5	V
		WS3235D62	3		5.9	V
Supply Voltage POR Threshold	V_{POR}	V_{POR} Rising	2.5	2.7	2.9	V
Deglitch Time of POR				8		ms
Under Voltage Lockout Threshold	V_{UVLO}	V_{UVLO} Falling	2.45		2.75	V
Input Quiescent Current	I_Q	$\overline{EN} = 0V$		330	400	μA
Input Shutdown Current	I_{SHDN}	$\overline{EN} = 5V$		55	70	
Protections						
Input OVP Threshold Voltage	V_{IN_OVP}	WS3235D	6.65	6.80	6.95	V
		WS3235D58	5.72	5.85	5.98	V
		WS3235D62	6.11	6.25	6.39	V
Input OVP Hysteresis				100	120	mV
Input OVP Propagation Delay		V_{IN} rising at $10V/\mu s$			0.1	μs
Input OVP Recovery Delay				8		ms
Over Current Protection	I_{OCP}	As $R_{ILIM} = 25k$	0.91	1	1.09	A
Over Current Protection Blanking Time	T_{OC}			180		μs
Over Current Recover Delay				64		ms
Battery Over Voltage Protection	V_{BOVP}	Rising	4.3	4.35	4.4	V
		Hysteresis		30		mV
Battery OVP Falling Threshold			4.25			V
Battery OVP Blanking Time	T_{VBOV}			180		μs
Battery OVP Recover Delay				8		ms
VB Pin Leakage Current		$V_{VB} = 4.4V$			85	
OTP Threshold	T_{SD}	Rising		155		$^\circ C$
		Hysteresis		30		$^\circ C$
OTP Recover Delay				8		ms

Soft-Start Time					8		ms
Logic							
$\overline{\text{EN}}$ Threshold Voltage	Logic-High	V_{IH}		1.5			V
	Logic-Low	V_{IL}				0.4	V
$\overline{\text{EN}}$ Internal Pull Down Resistor				170	220	270	k Ω
$\overline{\text{WRN}}$ Output Logic Low			Sink 1mA		0.19	0.3	V
$\overline{\text{WRN}}$ Output Logic High Leakage Current						0.1	μA
Power MOSFET							
On Resistance		R_{ON}	$I_{OUT} = 500\text{mA},$ $4.3\text{V} < V_{IN} < 6.5\text{V}$		200	300	m Ω

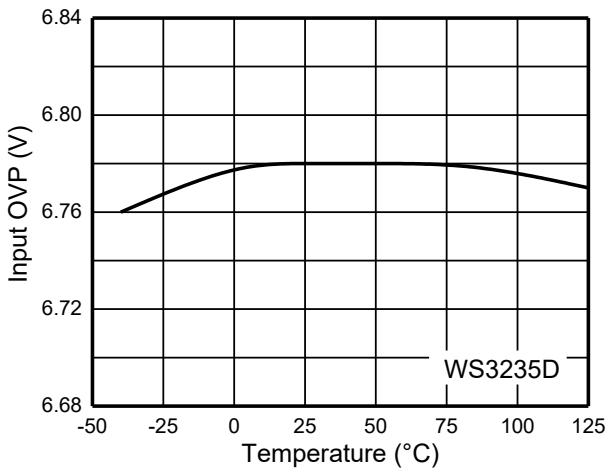
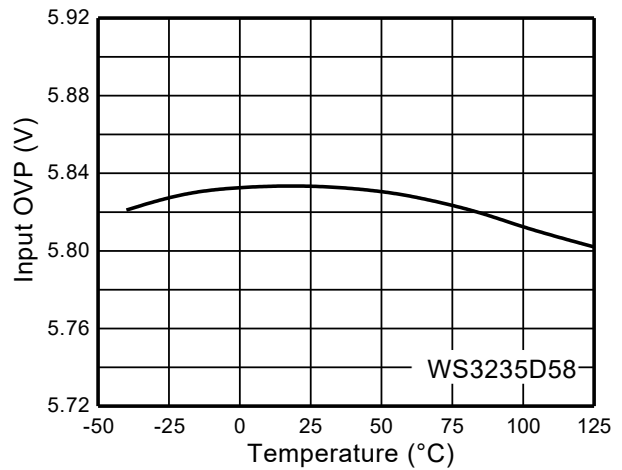
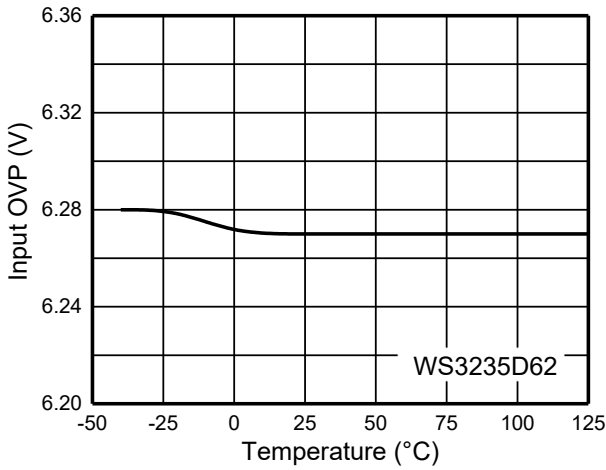
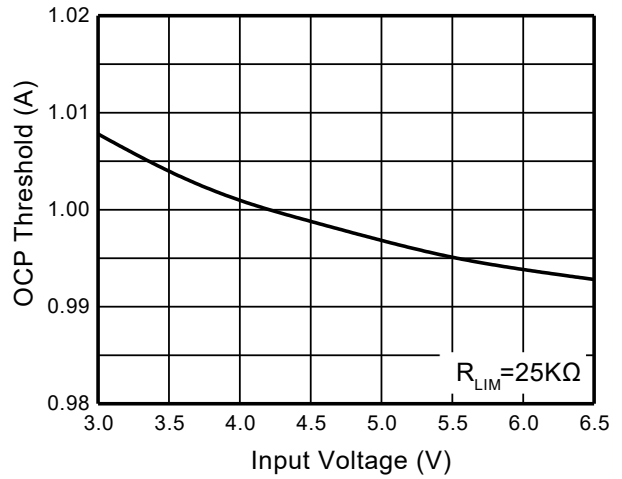
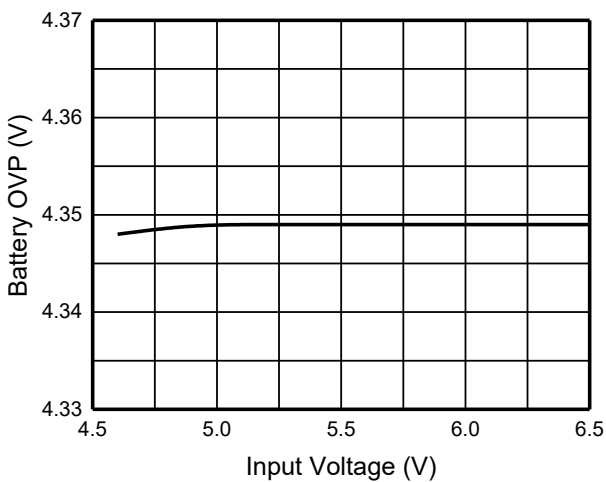
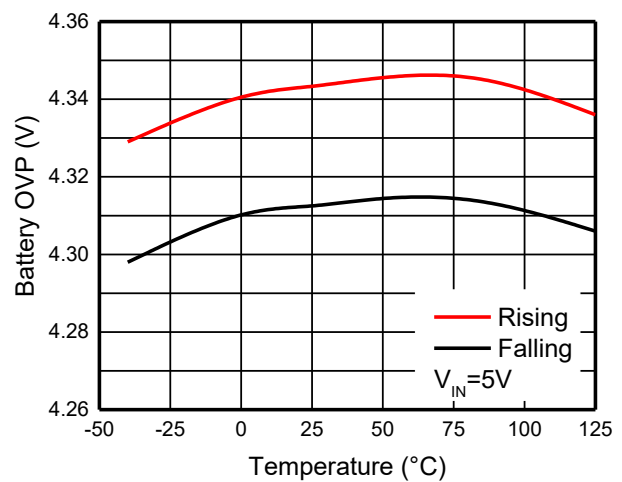
Typical Characteristics ($C_{IN}=1\mu F$, $C_{OUT}=1\mu F$, $T_A=25^\circ C$, WS3235D, unless otherwise noted)

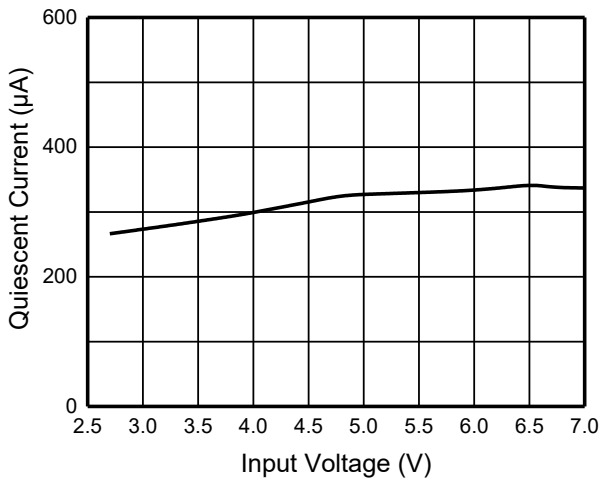
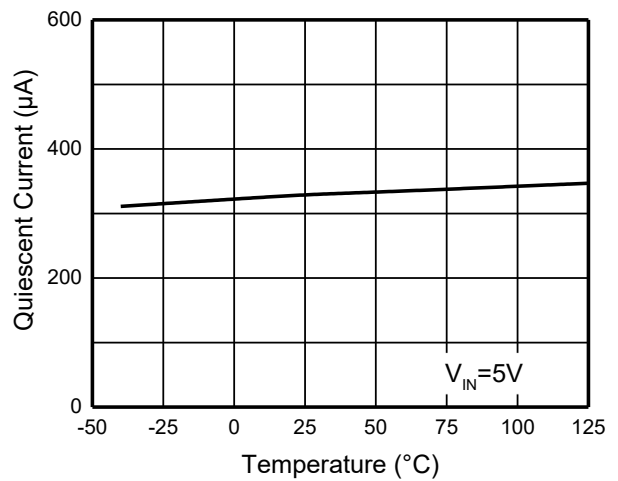
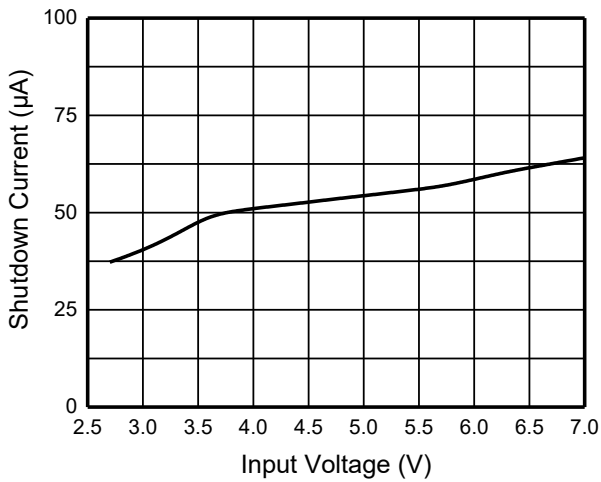
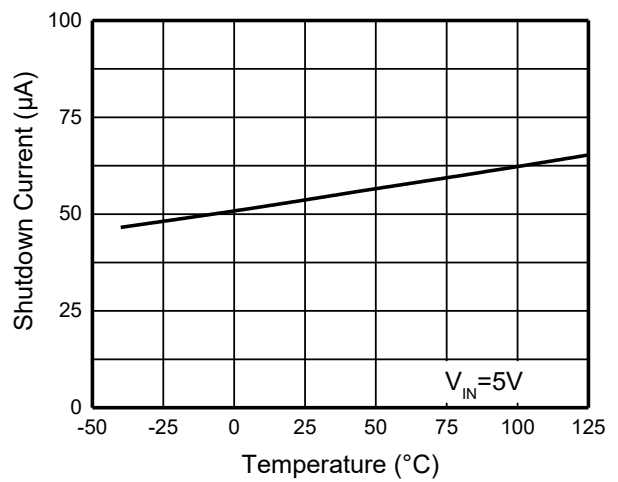
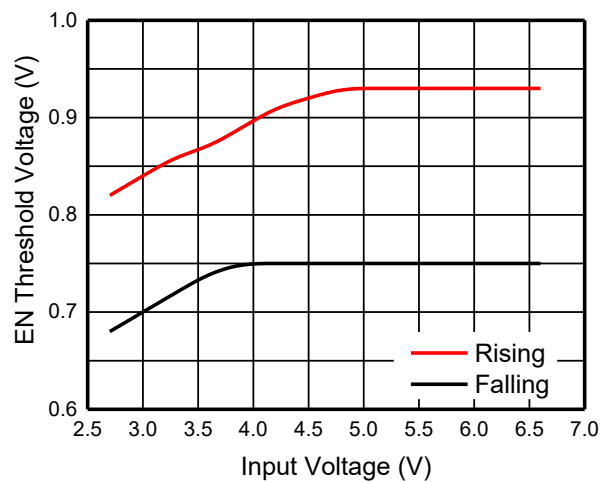
Input OVP vs. Temperature

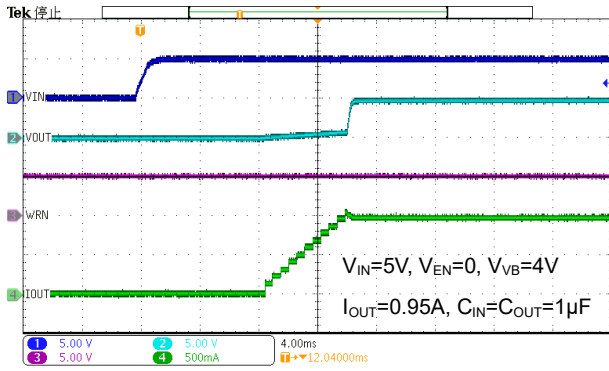
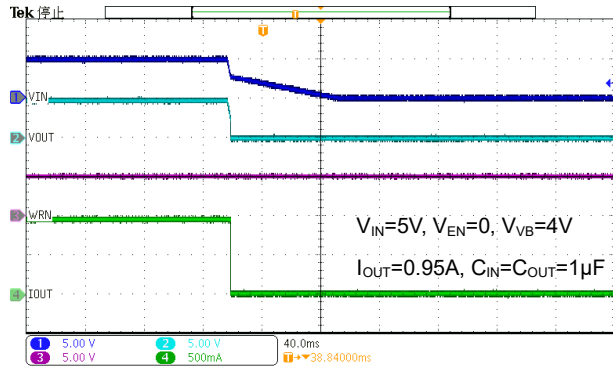
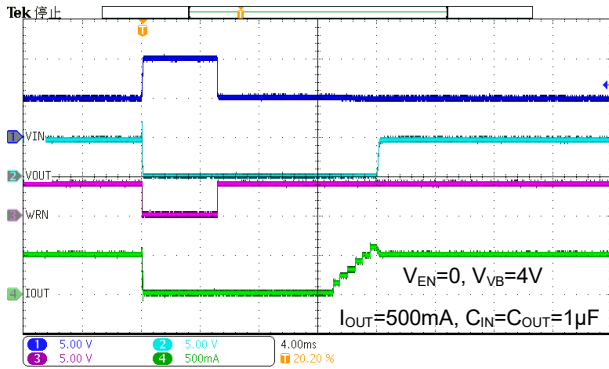
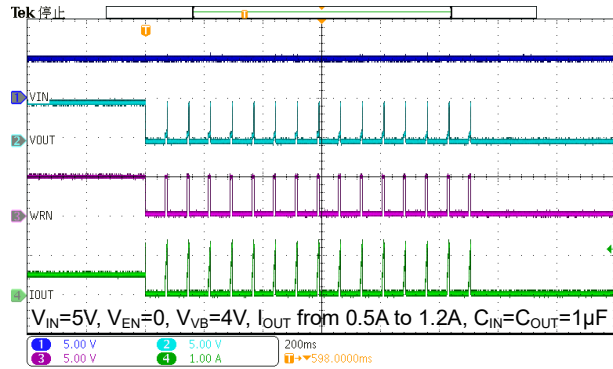
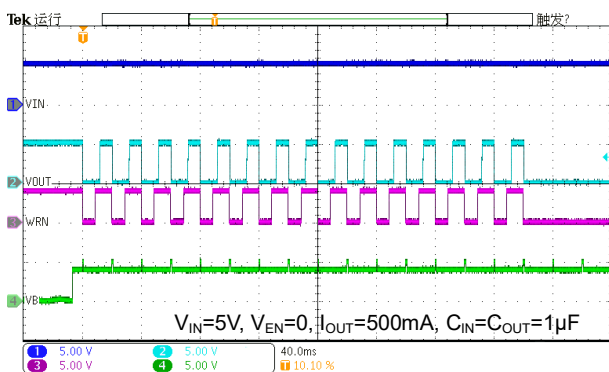
Input OVP vs. Temperature

Input OVP vs. Temperature

OCP Threshold vs. Input Voltage

Battery OVP vs. Input Voltage

Battery OVP vs. Temperature

Quiescent Current vs. Input Voltage

Quiescent Current vs. Temperature

Shutdown Current vs. Input Voltage

Shutdown Current vs. Temperature

EN Threshold Voltage vs. Input Voltage

Power On

Power Off

Input OVP

OCP

Battery OVP

Operation Information

Power Up

The WS3235 has a threshold of 2.7V power on reset (POR). The hysteresis of the POR threshold is 100mV. The IC is off before the input voltage reaches the POR threshold. When the input voltage is over the POR threshold, the WS3235 soft-start which can reduce the inrush current will be activated after 8ms delay. Any transients at the input during a hot insertion of the power supply will be settled down before the IC starts to operate.

Enable Control

The WS3235 offers a chip enable ($\overline{\text{EN}}$) input. There is an internal pull-down resistor in the $\overline{\text{EN}}$ pin. Pull this pin to low (<0.4V) or leave it floating to enable the IC and force it to high (>1.5V) to disable the IC.

Over Temperature Protection (OTP)

As soon as the junction temperature reaches 155°C, the WS3235 will turn off the MOSFET. And the IC will not turn on the MOSFET unless the junction temperature is cooled down 30°C.

Input Over Voltage Protection

The WS3235 input OVP threshold is set by the internal resistors. When the input voltage exceeds the threshold, the MOSFET is turned off in 0.1μs, removing power from the system. The hysteresis of the input OVP threshold is 100mV. When the input voltage returns to normal operation voltage range, the WS3235 will turn on the MOSFET.

Battery Over Voltage Protection

The battery OVP threshold voltage is set at 4.35V with 30mV hysteresis typically. To prevent transient voltage from triggering the battery OVP, the WS3235 has a built-in 180μs blanking time. If the battery OVP situation still exists after 180μs, the MOSFET will be turned off and the $\overline{\text{WRN}}$ pin indicates a LOW signal. The MOSFET will be turned off permanently if the battery OVP event occurs 16 times which is recorded by the counter. Reset input power or $\overline{\text{EN}}$ pin can turn on the MOSFET.

Over Current Protection (OCP)

The WS3235 OCP threshold can be set by an external resistor:

$$I_{\text{OCP}} = \frac{25000}{R_{\text{LIM}}}$$

The WS3235 has a built-in 180μs delay time to prevent any transient noise from triggering the OCP. If the OCP situation lasts for 180μs, the MOSFET will be turned off and the $\overline{\text{WRN}}$ pin indicates a LOW signal. After 64ms recover delay, the MOSFET will be turned on again. When the OCP occurs 16 times, the MOSFET will be turned off permanently unless the input power or the $\overline{\text{EN}}$ pin is reset.

Warning Indication Output

The $\overline{\text{WRN}}$ pin is an open-drain output that indicates a LOW signal when protection event occurs (Input OVP, Output OCP and Battery OVP). When the protection events are released and then the $\overline{\text{WRN}}$ pin indicates a HIGH signal.

Application Information

Capacitors Selection

Input over shoot voltage will be reduced by increasing the input capacitance, but in the meantime, it will increase the inrush current of input. The input over shoot voltage range which can be influenced by AC adapter hot-plugging is 1.5 to 2 times of the input voltage. The recommended capacitance on input and output is $1\mu\text{F}$, and the rated voltage should be higher than at 1.5 to 2 times of the operation voltage.

R_{VB} Selection

Battery OVP threshold error is determined by R_{VB} . Decrease the R_{VB} will reduce the battery OVP threshold error, but this will also increase the discharge current when the battery is reversed, which will easily cause reliability problems. To balance the negative factors, the resistance of $10\text{k}\Omega$ to $200\text{k}\Omega$ is allowed for R_{VB} .

PCB Layout Consideration

Following guidelines:

1. To reduce noise coupling, locate C_{IN} and C_{OUT} as close to the IC as possible and get them connect to ground plane.
2. R_{LIMIT} should be placed closed to ILIM pin as near as possible and connect to ground plane.
3. Keep main current traces as short and as wide as possible.
4. The exposed pad should be connected to a strong ground plane for heat sink.

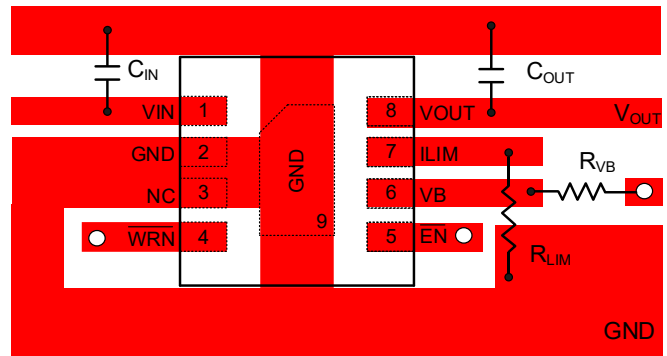

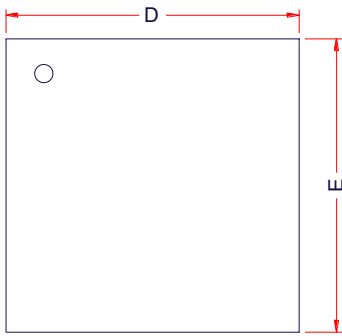
PACKAGE OUTLINE DIMENSIONS
DFN2x2-8L

TOP VIEW

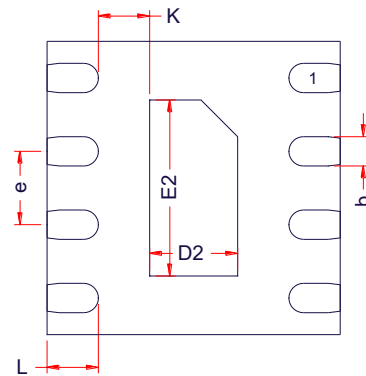

BOTTOM VIEW

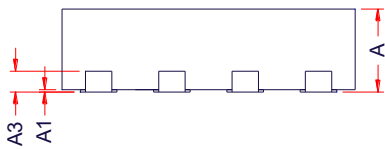

SIDE VIEW

Symbol	Dimensions in Millimeters		
	Min.	Typ.	Max.
A	0.70	0.75	0.80
A1	0.00	0.02	0.05
A3	0.20 Ref.		
b	0.20	0.25	0.30
D	1.90	2.00	2.10
E	1.90	2.00	2.10
D2	0.50	0.60	0.70
E2	1.10	1.20	1.30
e	0.50 BSC		
L	0.27	0.35	0.43
K	0.35 Ref.		

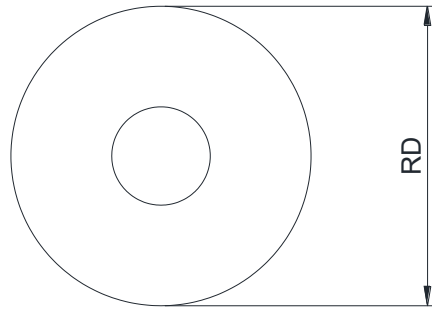
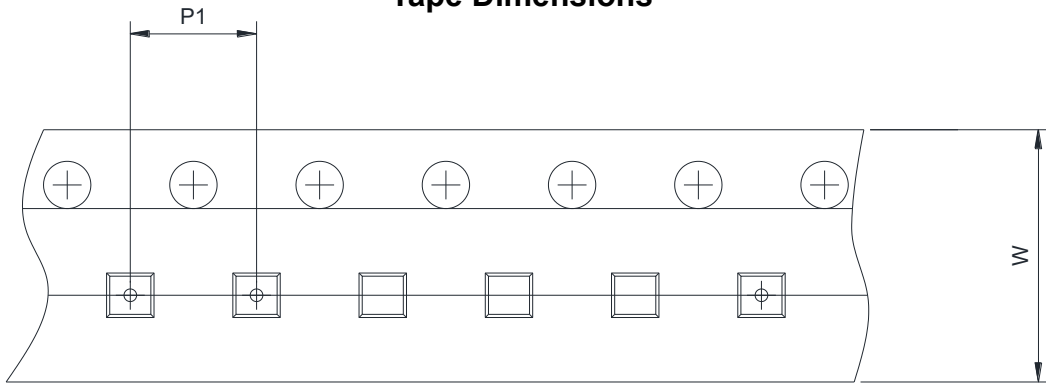
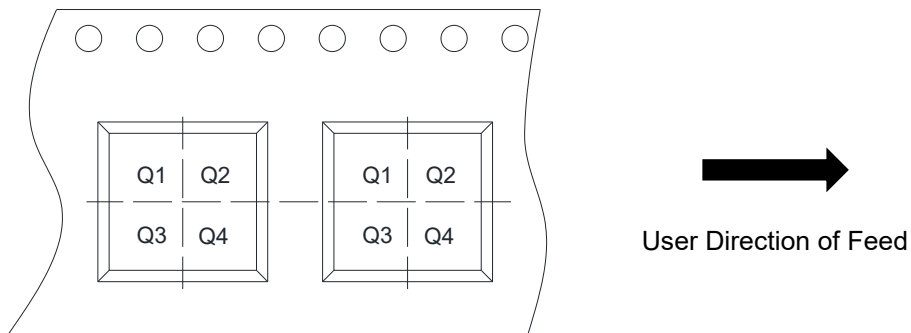
TAPE AND REEL INFORMATION
Reel Dimensions

Tape Dimensions

Quadrant Assignments For PIN1 Orientation In Tape

RD	Reel Dimension	<input checked="" type="checkbox"/> 7inch	<input type="checkbox"/> 13inch
W	Overall width of the carrier tape	<input checked="" type="checkbox"/> 8mm	<input type="checkbox"/> 12mm <input type="checkbox"/> 16mm
P1	Pitch between successive cavity centers	<input type="checkbox"/> 2mm	<input checked="" type="checkbox"/> 4mm <input type="checkbox"/> 8mm
Pin1	Pin1 Quadrant	<input checked="" type="checkbox"/> Q1	<input type="checkbox"/> Q2 <input type="checkbox"/> Q3 <input type="checkbox"/> Q4

X-ON Electronics

Largest Supplier of Electrical and Electronic Components

Click to view similar products for [Battery Management](#) category:

Click to view products by [Will Semiconductor](#) manufacturer:

Other Similar products are found below :

[NCP1851BFCCT1G](#) [NCP1855FCCT1G](#) [FAN54063UCX](#) [MP2615GQ-P](#) [LC05132C01NMTTTG](#) [ISL95522HRZ](#) [BD8665GW-E2](#)
[ISL95522AIRZ](#) [S-82D1AAE-A8T2U7](#) [S-82D1AAA-A8T2U7](#) [S-8224ABA-I8T1U](#) [MP2615CGQ-P](#) [ISL6251HRZ](#) [ISL6253HRZ](#) [ISL6292-2CR3](#) [ISL6292BCRZ-T](#) [ISL6299AIRZ](#) [ISL9211AIRU58XZ-T](#) [ISL9214IRZ](#) [ISL9220IRTZ-T](#) [FAN54161UCX](#) [DW01-A/J](#) [DW01A](#) [4056H](#)
[4056D](#) [TP4056](#) [TP4054](#) [TP4057](#) [IP2326_NPD](#) [IP2709_BF20WP](#) [TP4057](#) [TP4054](#) [TP4056-MS](#) [TP4057-MS](#) [TP4054-MS](#) [SY6982CQDC](#)
[SLM6335](#) [SLM6500S](#) [TP4057](#) [DW01](#) [AP5056HSPER](#) [EG4321](#) [GN4054B](#) [GN4054A](#) [HG4054M5/TR](#) [4060](#) [4061](#) [4061H](#) [4056A](#) [4056V](#)