

WS74242D

4-Channel Rail-to-Rail High Current VCOM Buffer

[Http://www.omnivision-group.com](http://www.omnivision-group.com)

Descriptions

The WS74242D is a 4-channel high performance, high voltage rail-to-rail buffer. It operates up to 20V. The device provides rail-to-rail output and common mode input capability beyond the rails, offering maximum dynamic range at any supply voltage.

The WS74242D provides fast slew rate and settling times, and a high output drive capability of up to 1250mA peak output current. The WS74242D features Over Temperature Protection (OTP), Over Current Protection (OCP) and Output Short Circuit Protection functions, which provide maximum system protection for TFT-LCD panel applications.

The WS74242D is available in the thermally enhanced 14-pin TSSOP package. Standard products are Pb-Free and halogen-Free.

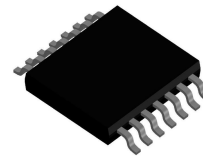

TSSOP-14L

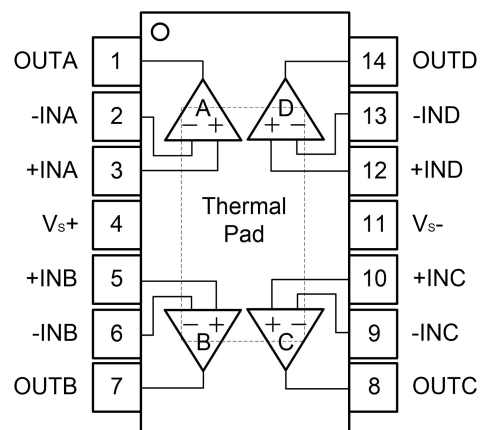

TSSOP-14L

Pin configuration (Top view)

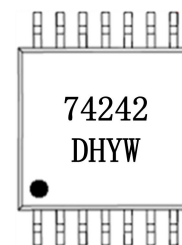

TSSOP-14L

Applications

- TV TFT-LCD Panels
- TFT-LCD Monitors
- Notebooks and Netbooks
- Personal Communication Devices
- Digital Signage
- Touch-Screen Displays
- ADC/DAC Buffers and Active Filters

Features

- Beyond the rails input capability
- 1250mA peak output current
- 32MHz – 3dB Bandwidth
- Rail-to-rail output swing
- Power supply range from 4V to 20V
- Low supply current per amplifier: 1.3mA
- High Slew Rate: 60V/ μ s
- Unity-gain stable
- Protection Function
 - Over Temperature Protection (OTP)
 - Over Current Protection (OCP)
 - Output Short Protection

Marking

74242 = Device code
Y = Year code
W = Week code

Order information

Device	Package	Shipping
WS74242DH-14/TR	TSSOP-14L	4000/Reel &Tape

Pin Descriptions

Pin Number	Symbol	Descriptions
1	OUTA	Output of Amplifier-A
2	-INA	Inverting Input of Amplifier-A
3	+INA	Non-inverting Input of Amplifier-A
4	V _{S+}	Positive Power Supply
5	+INB	Non-inverting Input of Amplifier-B
6	-INB	Inverting Input of Amplifier-B
7	OUTB	Output of Amplifier-B
8	OUTC	Output of Amplifier-C
9	-INC	Inverting Input of Amplifier-C
10	+INC	Non-inverting Input of Amplifier-C
11	V _{S-}	Negative Power Supply.
12	+IND	Non-inverting Input of Amplifier-D
13	-IND	Inverting Input of Amplifier-D
14	OUTD	Output of Amplifier-D
EP	Thermal Pad	Exposed Pad. The exposed pad must be soldered to a large PCB and connected to system ground for maximum thermal dissipation.

Absolute Maximum Ratings⁽¹⁾

Parameter	Symbol	Value	Unit
Supply Voltage, ([V _{S+}] - [V _{S-}])	V _S	22	V
Input Common Mode Voltage Range	V _{ICR}	(V _{S-})-0.3 to (V _{S+})+0.3	V
Operating Free-Air Temperature Range	T _A	-40 to 85	°C
Operating Junction Temperature Range	T _J	-40 to 150	°C
Storage Temperature Range	T _{STG}	-65 to 150	°C
Junction to Ambient Thermal Resistance	θ _{JA} ⁽³⁾	43	°C / W
Junction to Board Thermal Resistance	θ _{JB} ⁽³⁾	17.2	
Junction to Case (Top) Thermal Resistance	θ _{JCtop} ⁽³⁾	16.3	
Junction to Case (Bottom) Thermal Resistance	θ _{JCbot} ⁽³⁾	3.7	

Note:

1. Stresses beyond those listed under Absolute Maximum Ratings may cause permanent damage to the device.
2. Exposure to absolute-maximum-rated conditions for extended periods may affect device reliability.
3. Single component mounted on 2oz, 1.5*1.5 inch² FR4 PCB with 1.0*1.0 inch² Cu area.

ESD, Electrostatic Discharge Protection

Symbol	Parameter	Condition	Minimum level	Unit
HBM	Human Body Model ESD of Output Pins	MIL-STD-883H Method 3015.8	±6000	V
	Human Body Model ESD of Other Pins	JEDEC-EIA/JESD22-A114A	±3000	
CDM	Charged Device Model ESD	JEDEC-EIA/JESD22-C101E	±2000	V
MM	Machine Model ESD	JEDEC-EIA/JESD22-A115	±400	V

Electronics Characteristics

$V_{S+} = 19V$, $V_{S-} = 0V$, $V_{INX+} = 9.5V$, 4CH unity gain ($V_{INX-} = V_{OUTX}$), with $R_L = 10k\Omega$ and $C_L = 10pF$ unless otherwise specified. Typical values are tested at $+25^{\circ}C$ ambient temperature

Symbol	Parameter	Conditions	Min.	Typ.	Max.	Unit
$(V_{S+})-(V_{S-})$	Supply Voltage Range		4	-	19	V
I_S	Supply Current		-	5.2	8	mA
V_{OS}	Input Offset Voltage		-15	+3	+15	mV
I_B	Input Bias Current		-0.1	-	+0.1	nA
V_{OL}	Output Swing Low	$V_{INX+} = 0V$, $I_L = -5mA$	-	18	25	mV
V_{OH}	Output Swing High	$V_{INX+} = 18V$, $I_L = +5mA$	-	23	30	mV
I_O	Continue Output Current	Before OTP	-	± 400	-	mA
I_{Peak}	Peak Output Current		-	± 1250	-	mA
SR	Slew Rate	0.5V to 17.5V, 20% to 80%	-	60	-	V/ μs
BW	Bandwidth	-3dB	-	32	-	MHz
A_{VOL}	Open-Loop Gain	$R_L = 10k\Omega$	-	100	-	dB
PSRR	Power Supply Rejection Ration	$6V < (V_{S+})-(V_{S-}) < 18V$	90	116	-	dB
CMIR	Common-Mode Input Range		-0.1	-	19.1	V
CMRR	Common-Mode Rejection Ration	$R_L = 10k\Omega$	-	78	-	dB
T_{SD}	Thermal Shutdown		-	150	-	$^{\circ}C$

Applications Information

Unused Amplifiers

It is strongly recommended to configure any unused amplifiers as unity gain buffer and directly tie the non-inverting input to the ground plane.

Protection Functions

The WS74242D features over temperature protection (OTP), over current protection (OCP), and output short circuit protection functions. These features provide maximum system protection for demanding TFT LCD panel applications.

The WS74242D limits the peak output current to $\pm 1250\text{mA}$ and the continue output current to $\pm 400\text{mA}$ for normal operation. If the output of the WS74242D is shorted to V_{S-} or V_{S+} , the over current protection (OCP) mechanism will be activate to regulate the power dissipation to prevent overstressing of the power bus.

The over temperature protection (OTP) function of the WS74242D monitors the silicon junction temperature. When the junction temperature exceeds 150°C , the OTP protection circuit disables normal operation to lower the chip operating temperature.

The synergistic operation of the OTP, OCP, peak output current limit and continue output current limit functions provides maximum output short protection for the WS74242D.

Power Dissipation

The WS74242D design is optimized to deliver maximum output current driving capability for TFT LCD panel applications. Due to its robust protection features, the WS74242D can endure a momentary output short to ground (or V_{S-}).

Due to its high current driving capability, it is possible for the junction temperature to exceed 150°C under certain output current load conditions. Therefore, it is very important to calculate the WS74242D's maximum junction temperature and maximum power dissipation for the application to make sure that the junction temperature does not exceed 150°C or maximum package power rating to ensure the device stays in the safe operating region.

Driving Capacitive Loads

The strong output current driving capability of the WS74242D allows for a high slew rate even with large capacitive loads. Sometimes there is output peaking for certain application loads and application configurations. If less output peaking is desired for these applications, a small damping resistor (usually between 2Ω and 15Ω) can be connected in series between the output of WS74242D and the load.

However, this topology will reduce the gain slightly.

Another method of reducing output peaking is to add a snubber circuit at the output. A snubber circuit consists of a resistor (such as 100Ω - 200Ω) in series with a capacitor (such as 10nF), which improves output settling time and reduces peaking. The advantage of this topology is that it draws no DC current nor does it reduce the gain.

Bypass Capacitors

For stability while driving load transients, and to minimize the noise to the system, use a $10\mu\text{F}$ capacitor for the V_{S+} supply. Connect this bypass capacitor as close as possible to the input V_{S+} .

Layout

Connect the exposed pad of the device to the V_{S-} or GND plane for best thermal dissipation performance, or low thermal resistance. In typical application, V_{S-} is connected to ground.

Typical Characteristics

$T_A=25^\circ\text{C}$, $V_S=5\text{V}$, $V_{CM}=V_S/2$, unless otherwise noted

Small-Signal Step Response

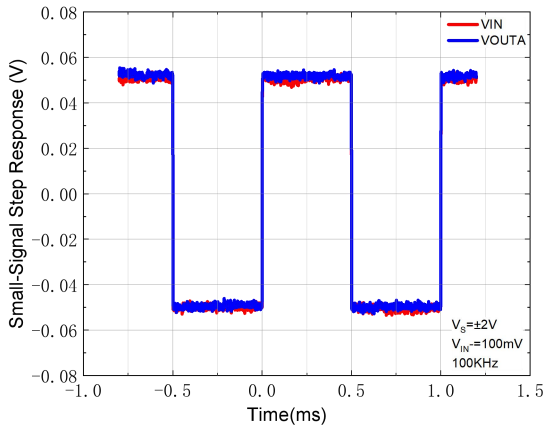

Large-Signal Step Response

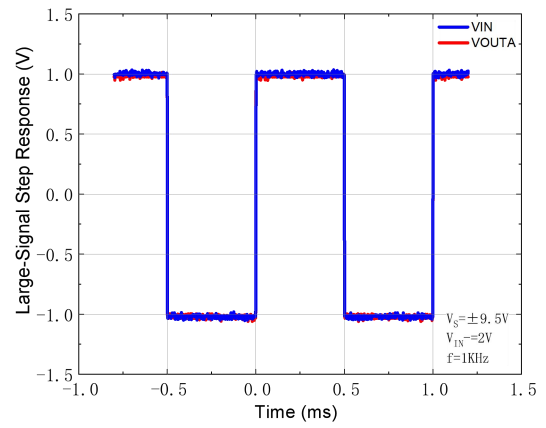

Slew Rate

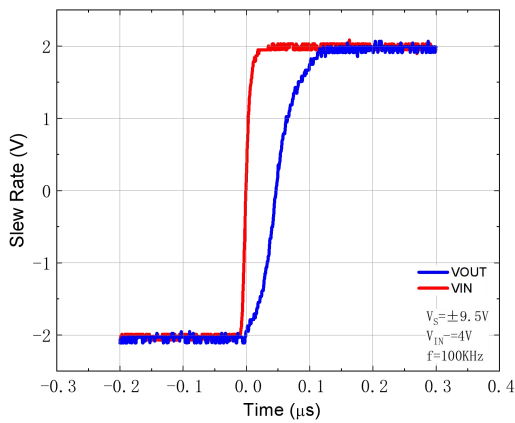

Slew Rate

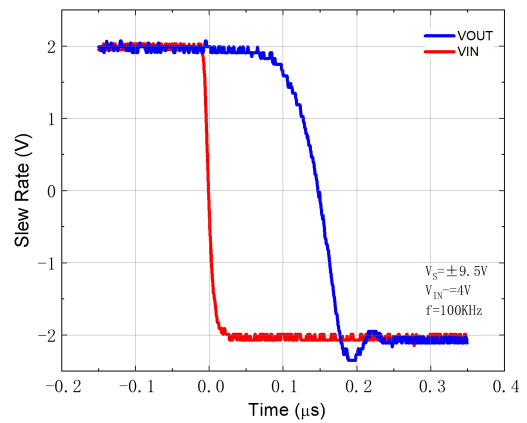

CMRR

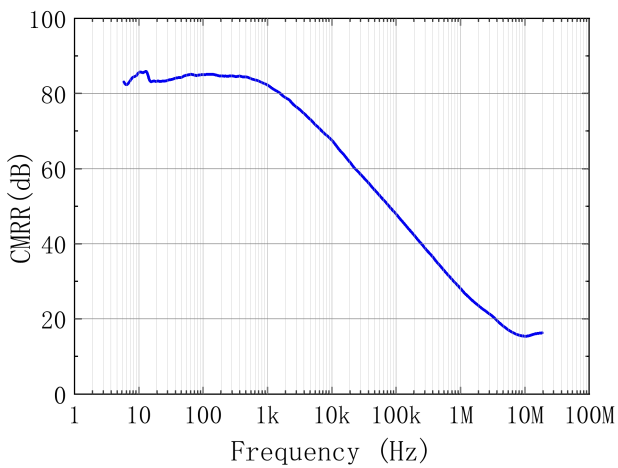

PSRR

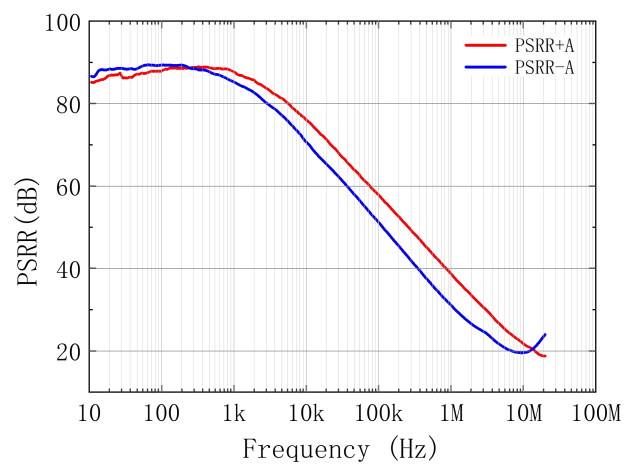

Typical Characteristics

$T_A=25^\circ\text{C}$, $V_S=5\text{V}$, $V_{CM}=V_S/2$, unless otherwise noted

-3dB

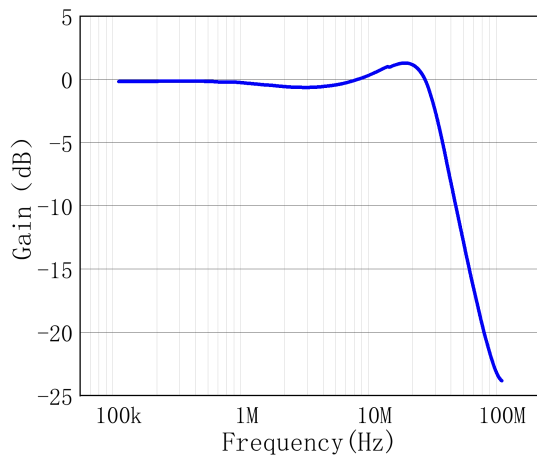

Open-Loop Gain and Phase

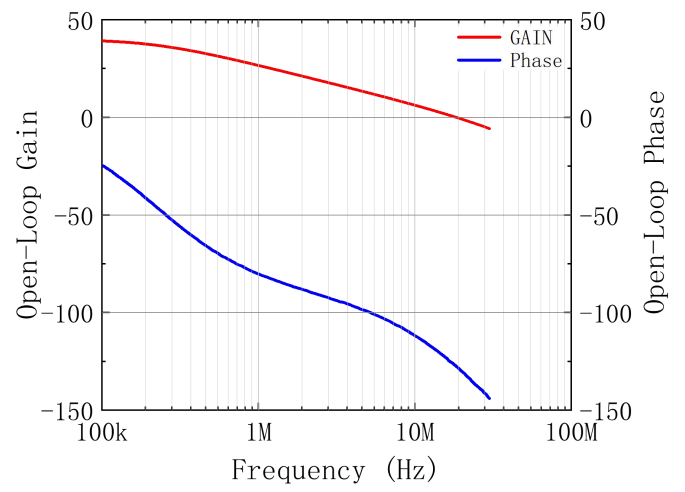

PACKAGE OUTLINE DIMENSIONS

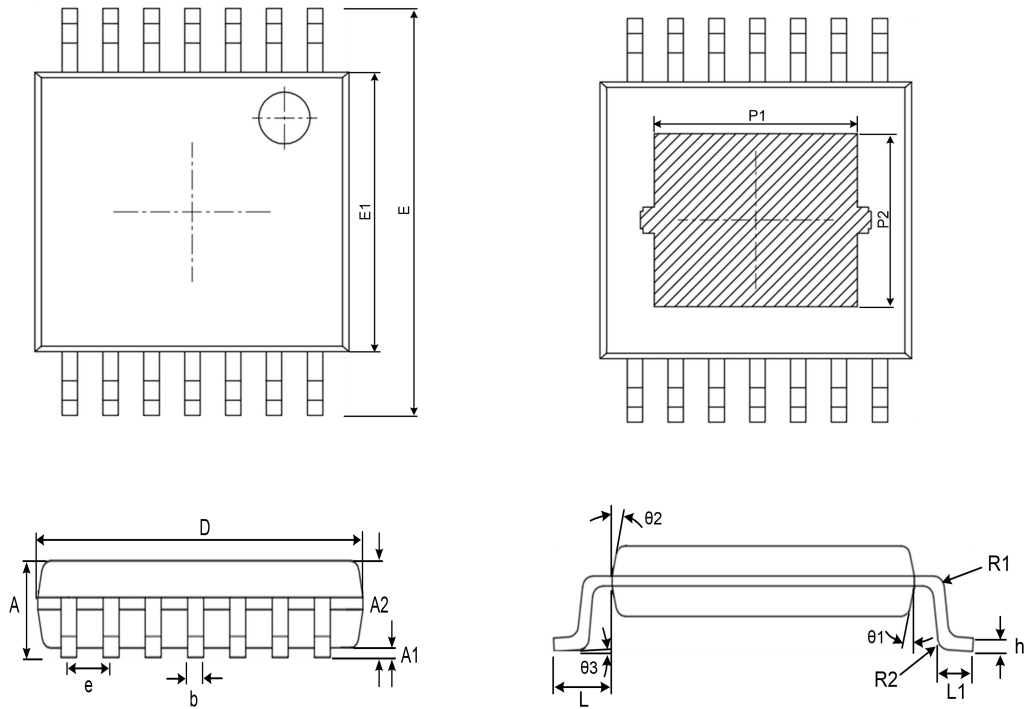

Symbol	Dimensions In Millimeters (mm)		
	Min.	Typ.	Max.
A	-	-	1.20
A1	0.05	-	0.15
A2	0.80	-	1.05
D	4.90	-	5.10
e	0.65 BSC		
b	0.19	-	0.30
E	6.25	-	6.55
E1	4.30	-	4.50
P1	3.30	-	3.70
P2	2.90	-	3.20
L	-	-	1.00
L1	0.45	-	0.75
R1	-	0.15	-
R2	-	0.15	-
θ1	-	12°	-
θ2	-	12°	-
θ3	0°	-	8°
h	0.09	-	0.20

TAPE AND REEL INFORMATION

Reel Dimensions

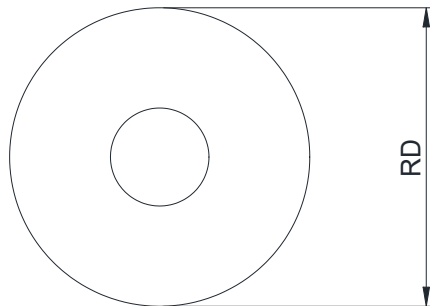

Tape Dimensions

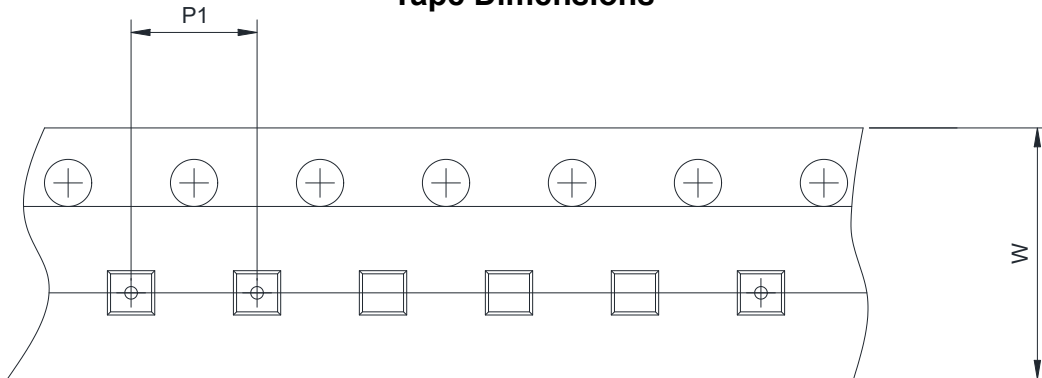

Quadrant Assignments For PIN1 Orientation In Tape

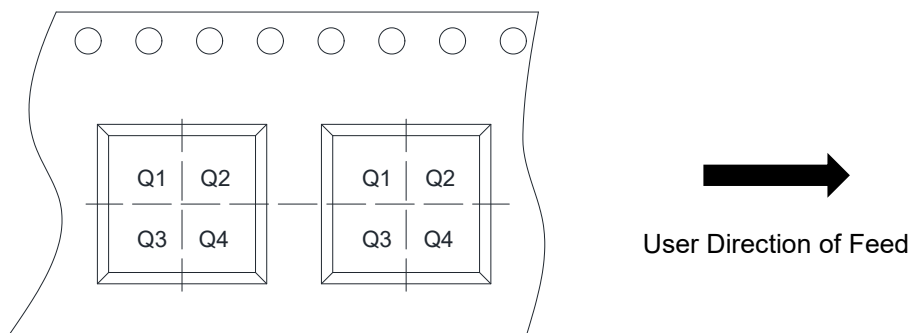

RD	Reel Dimension	<input type="checkbox"/> 7inch	<input checked="" type="checkbox"/> 13inch		
W	Overall width of the carrier tape	<input type="checkbox"/> 8mm	<input checked="" type="checkbox"/> 12mm		
P1	Pitch between successive cavity centers	<input type="checkbox"/> 2mm	<input type="checkbox"/> 4mm	<input checked="" type="checkbox"/> 8mm	
Pin1	Pin1 Quadrant	<input checked="" type="checkbox"/> Q1	<input type="checkbox"/> Q2	<input type="checkbox"/> Q3	<input type="checkbox"/> Q4

X-ON Electronics

Largest Supplier of Electrical and Electronic Components

Click to view similar products for [Buffers & Line Drivers](#) category:

Click to view products by [Will Semiconductor](#) manufacturer:

Other Similar products are found below :

[LXV200-024SW](#) [74AUP2G34FW3-7](#) [HEF4043BP](#) [NL17SG125DFT2G](#) [NLU1GT126CMUTCG](#) [CD4041UBE](#) [54FCT240CTDB](#)
[74HCT540N](#) [DS14C88N](#) [070519XB](#) [NL17SZ07P5T5G](#) [74LVC2G17FW4-7](#) [CD4502BE](#) [5962-8982101PA](#) [61446R00](#) [NL17SH17P5T5G](#)
[NLV37WZ17USG](#) [74HCT126T14-13](#) [74VHC9126FT\(BJ\)](#) [RHRXH162244K1](#) [74AUP1G34FW5-7](#) [74AUP1G07FW5-7](#) [74LVC1G126FW4-7](#)
[74LVC2G126RA3-7](#) [74LVCE1G125FZ4-7](#) [54FCT240TLB](#) [NLX3G16DMUTCG](#) [NLX2G06AMUTCG](#) [LE87100NQCT](#) [LE87285NQC](#)
[LE87290YQC](#) [LE87290YQCT](#) [74AUP1G125FW5-7](#) [NLU2G16CMUTCG](#) [MC74LCX244MN2TWG](#) [NL17SG17P5T5G](#)
[NLV74HC125ADR2G](#) [NLVHCT245ADTR2G](#) [NLVVHC1G126DFT2G](#) [EL5623IRZ](#) [ISL15102AIRZ-T13](#) [ISL1539IRZ-T13](#)
[MC100EP17MNG](#) [MC74HCT365ADR2G](#) [MC74LCX244ADTR2G](#) [NL27WZ126US](#) [NL37WZ16US](#) [NLU1G07MUTCG](#) [NLU2G07MUTCG](#)
[NLX3G17BMX1TCG](#)