

WS74607
Capless 2Vrms to 3Vrms Audio Driver with Adjustable Gain
[Http://www.willsemi.com](http://www.willsemi.com)
Descriptions

The WS74607 is an integrated solution for Set-top box and high definition player, and designed to optimize the audio driver circuit performance while reducing the BOM cost by eliminating the peripheral discrete components for noise reduction. WS74607 features a 3Vrms stereo audio driver that designed to allow for the removal of output AC-coupling capacitors.

Featuring single-ended input mode, gain range of $\pm 1V/V$ to $\pm 10V/V$ can be achieved via external gain resistor setting. The WS74607 is able to offer 3Vrms output at 600 Ω load with 5V supply. Meanwhile, the WS74607 offers built-in shut-down control circuitry for optimal pop-free performance. Under under-voltage condition, WS74607 is able to detect it and mutes the output. WS74607 satisfies MSL3 level requirements.

Applications

- Set-Top Boxes
- High Definition DVD Players
- Car Entertainment System
- Medical

Features

- Single Supply Voltage : 3.0V~5.5V
- THD+N : >100dB
- SNR : >112dB
- -40°C to 85°C Operation Range
- Voltage Output at 600 Ω Load
2Vrms with 3.3V supply voltage
3Vrms with 5.0V supply voltage
- No Pop/Clicks Noise when Power ON/OFF
- No Need Output DC-Blocking Capacitors
- Optimized Frequency Response between 20Hz~20kHz
- Accepting Differential Input
- Featuring external under voltage mute
- Available in MSOP-10L package
- Ultra Low noise and THD

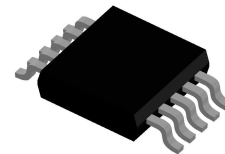
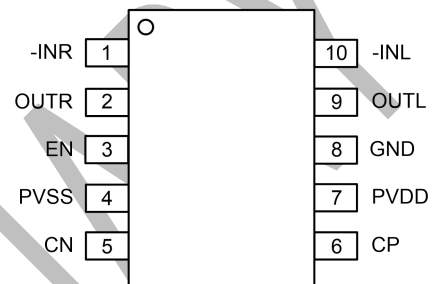
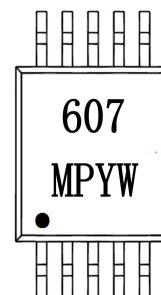
MSOP-10L

Pin Configuration (Top View)

Marking

607 = Device code
MP = Special code
Y = Year code
W = Week code

Order Information

Device	Package	Shipping
WS74607M-10/TR	MSOP-10L	4000/Reel &Tape

Pin Descriptions

Pin Number	Symbol	Descriptions
1	-INR	Right-channel negative input
2	OUTR	Right-channel output
3	EN	Enable input, active-high
4	PVSS	Negative supply
5	CN	Charge-pump flying capacitor negative
6	CP	Charge-pump flying capacitor positive
7	PVDD	Positive supply
8	GND	Ground
9	OUTL	Left-channel output
10	-INL	Left-channel negative input

Absolute Maximum Ratings

Parameter	Symbol	Value	Unit
Supply Voltage	$V_{DD}^{(2)}$	6	V
Input Differential Voltage	$V_{IDR}^{(3)}$	± 6	V
Input Common Mode Voltage Range	V_{ICR}	$(V^-)-0.2$ to $(V^+)+0.2$	V
Output Short-Circuit Duration	t_{SO}	Unlimited	/
Operating Free-Air Temperature Range	T_A	-40 to 85	$^{\circ}C$
Storage Temperature Range	T_{STG}	-65 to 150	$^{\circ}C$
Junction Temperature Range	T_J	150	$^{\circ}C$
Lead Temperature Range	T_L	260	$^{\circ}C$
MSOP-10 θ_{JA}		190	$^{\circ}C/W$

Note:

- Stresses beyond those listed under Absolute Maximum Ratings may cause permanent damage to the device. These are only stress ratings, and functional operation of the device at these or any other conditions beyond those indicated under recommended operating conditions are not implied. Exposure to absolute-maximum-rated conditions for extended periods may affect device reliability.
- All voltage values, except differential voltage are with respect to network terminal.
- Differential voltages are at IN+ with respect to IN-.

ESD, Electrostatic Discharge Protection

Symbol	Parameter	Condition	Minimum level	Unit
HBM	Human Body Model ESD	MIL-STD-883H Method 3015.8 JEDEC-EIA/JESD22-A114A	4	kV
MM	Machine Model ESD	JEDEC-EIA/JESD22-A115	200	V
CDM	Charged Device Model ESD	JEDEC-EIA/JESD22-C101E	2	kV

Electronics Characteristics

The *denotes the specifications which apply over the full operating temperature range, otherwise specifications are at $T_A = 25^\circ\text{C}$. $V_{DD} = 5\text{V}$, $R_L = 25\text{k}\Omega$

Symbol	Parameter	Conditions	Min.	Typ.	Max.	Unit	
V_{DD}	Supply Voltage		*	3	5	5.5	V
V_{IH}	EN High level input voltage			1.1			V
V_{IL}	EN Low level input voltage				0.4		V
T_A	Operating Temperature Range		*	-40		85	$^\circ\text{C}$
V_{os}	Output Offset Voltage	$V_{DD}=3\text{V}$ to 5V , input grounded, unity gain.	*	-3.5	0.6	3.5	mV
OVP	V_{DD} Over Voltage Protection	$V_{DD}>5.5\text{V}$ then device shutdown.			5.75		V
PSRR	Power Supply Rejection Ratio			90			dB
V_{OH}	High Level Output Voltage	$V_{DD}=5\text{V}$ $R_L=2.5\text{k}\Omega$		4.92			V
		$V_{DD}=3.3\text{V}$ $R_L=2.5\text{k}\Omega$		3.15			V
V_{OL}	Low Level Output Voltage	$V_{DD}=5\text{V}$ $R_L=2.5\text{k}\Omega$		-4.65			V
		$V_{DD}=3.3\text{V}$ $R_L=2.5\text{k}\Omega$			-3		V
I_{IH}	EN High level input current	$V_{DD}=5\text{V}$ $V_i=V_{DD}$	*		1		μA
I_{IL}	EN Low level input current	$V_{DD}=5\text{V}$ $V_i=0$	*		1		μA
I_{DD}	Quiescent Current	$V_{DD}=3.3\text{V}$ $V_i=V_{DD}$		10.8			mA
		$V_{DD}=5\text{V}$ $V_i=V_{DD}$		12.8			
		Shut down mode $V_{DD} = 3-5\text{V}$			0.15		
V_o	Output Voltage	THD=1%, $V_{DD}=3.3\text{V}$ $f=1\text{kHz}$		2.05			V_{rms}
THD+N	Total Harmonic Distortion and Noise	$V_o=2V_{rms}$ $f=1\text{kHz}$ $R_L=600\Omega$, $V_{DD}=3.3\text{V}$			0.001		%
X_{TALK}	Channel cross talk	$V_o=2V_{rms}$ $f=1\text{kHz}$, $V_{DD}=3.3\text{V}$			100		dB
I_o	Maximum output current	$V_{DD}=3.3\text{V}$			30		mA
SNR	Signal noise ratio	$V_o=2V_{rms}$ BW=22kHz A-weighted and $V_{DD}=3.3\text{V}$			110		dB
SR	Slew Rate				12		$\text{V}/\mu\text{s}$
V_N	Noise output voltage	BW=20Hz to 22kHz, $V_{DD}=3.3\text{V}$			5.1		μV_{rms}
G_{BW}	Gain-Bandwidth Product	$V_{DD}=3.3\text{V}$			5		MHz
A_{VO}	Open Loop Large Signal Gain	$V_{DD}=3.3\text{V}$			100		dB
f_{CP}	Charge pump frequency	$V_{DD}=3.3\text{V}$			400		kHz

Electronics Characteristics (continued)

The *denotes the specifications which apply over the full operating temperature range, otherwise specifications are at $T_A = 25^\circ\text{C}$. $V_{DD} = 5\text{V}$, $R_L = 25\text{k}\Omega$

Attenuation@mute	Input-to-output attenuation in shutdown	EN=0V, $V_{DD}=3.3\text{V}$		90		dB
V_o	Output Voltage	THD=1%, $V_{DD}=5\text{V}$ f=1kHz	3.05			V_{rms}
THD+N	Total Harmonic Distortion and Noise	$V_o=2V_{\text{rms}}$, f=1kHz $R_L=600\Omega$, $V_{DD}=5\text{V}$		0.001		%
X_{TALK}	Channel cross talk	$V_o=2V_{\text{rms}}$, f=1kHz, $V_{DD}=5\text{V}$		95		dB
I_o	Maximum output current	$V_{DD}=5\text{V}$		60		mA
SNR	Signal noise ratio	$V_o=2V_{\text{rms}}$, BW=22kHz A-weighted $V_{DD}=5\text{V}$		112		dB
SR	Slew Rate			12		V/ μs
V_N	Noise output voltage	BW=20Hz to 22kHz, $V_{DD}=5\text{V}$		4.5		μV_{rms}
G_{BW}	Gain-Bandwidth Product	$V_{DD}=5\text{V}$		7		MHz
A_{VO}	Open Loop Large Signal Gain	$V_{DD}=5\text{V}$		110		dB
f_{CP}	Charge pump frequency	$V_{DD}=5\text{V}$		410		kHz
Attenuation@mute	Input-to-output attenuation in shutdown	EN=0V, $V_{DD}=5\text{V}$		90		dB

Note:

1. Stresses beyond those listed under Absolute Maximum Ratings may cause permanent damage to the device. Exposure to any Absolute Maximum Rating condition for extended periods may affect device reliability and lifetime.
2. A heat sink may be required to keep the junction temperature below the absolute maximum rating when the output is shorted indefinitely.

Typical Characteristics
 $T_A=25^{\circ}\text{C}$, $V_{DD}=3.3\text{V}$, unless otherwise noted

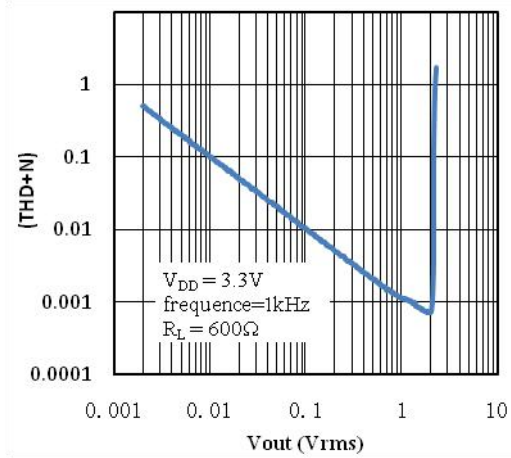
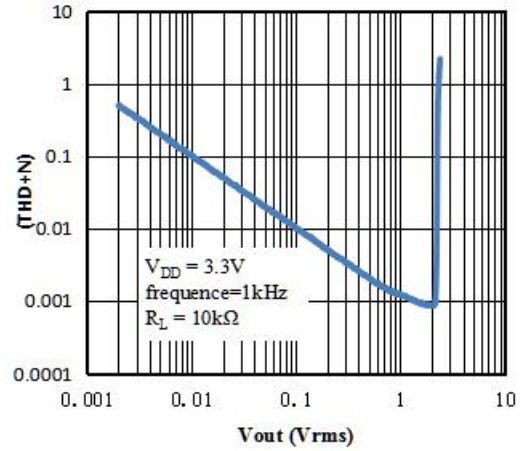
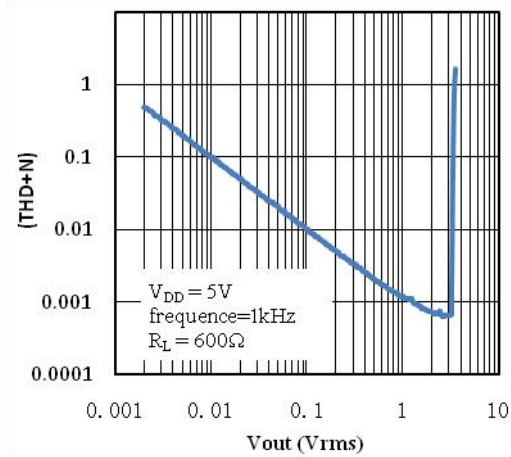
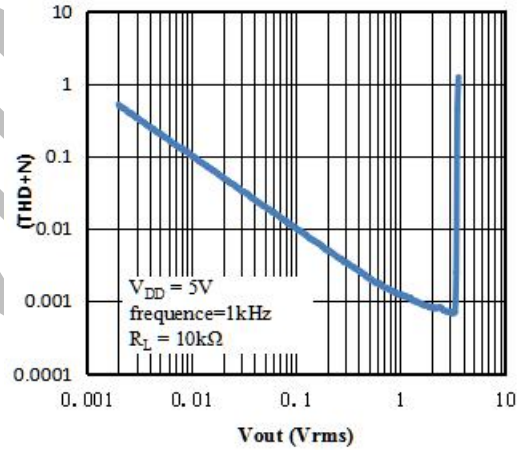
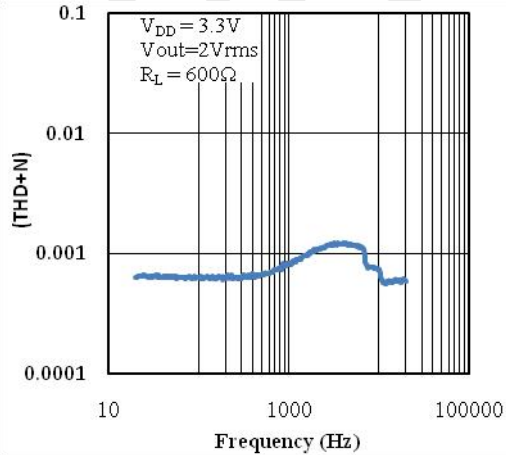
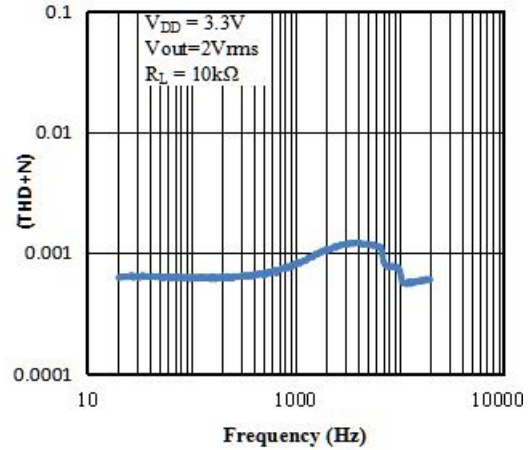
THD+N vs. Output Voltage

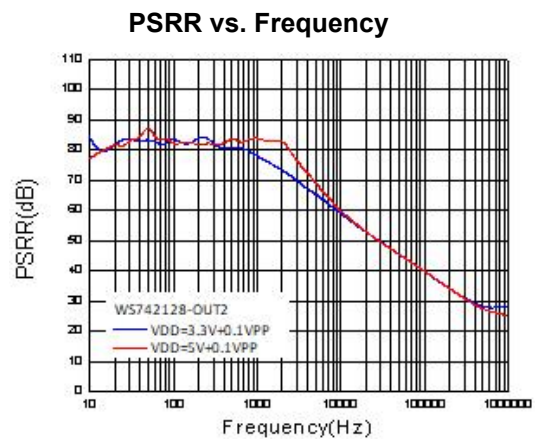
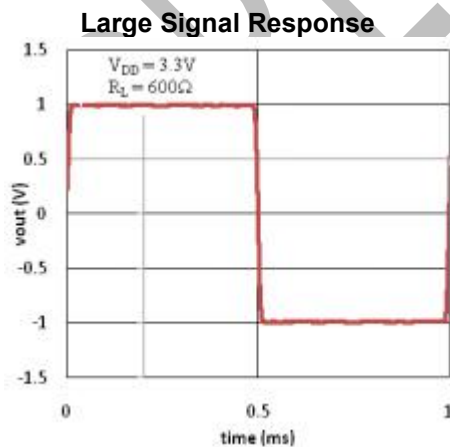
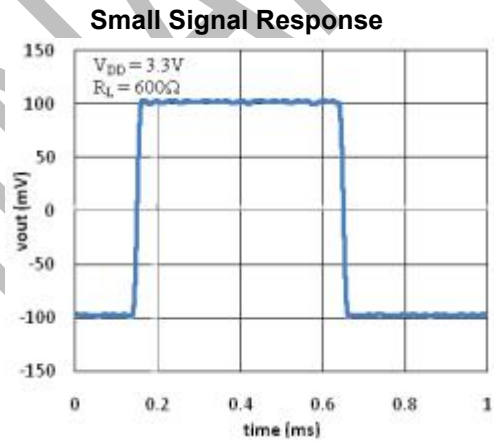
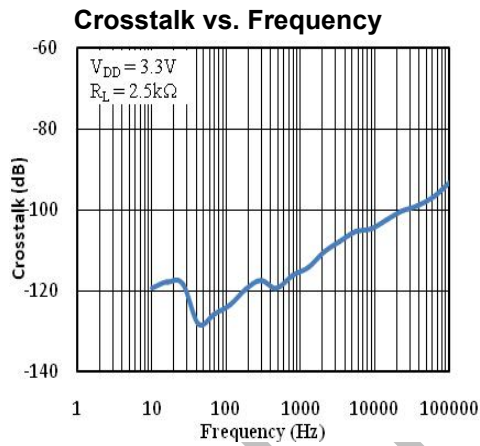
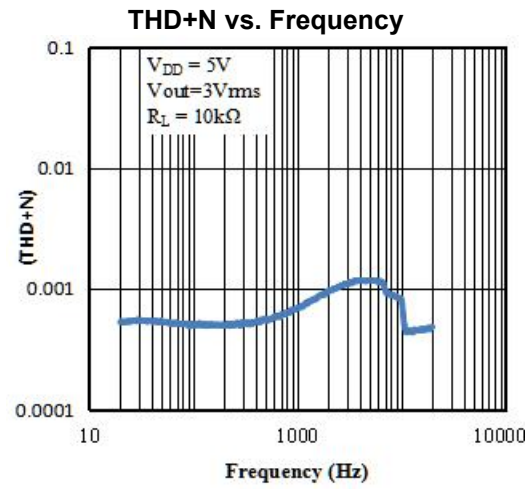
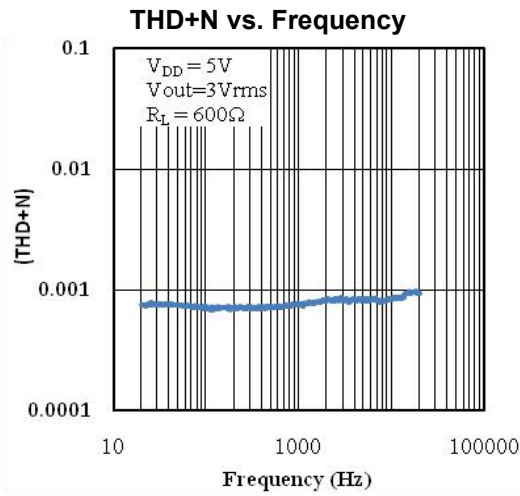
THD+N vs. Output Voltage

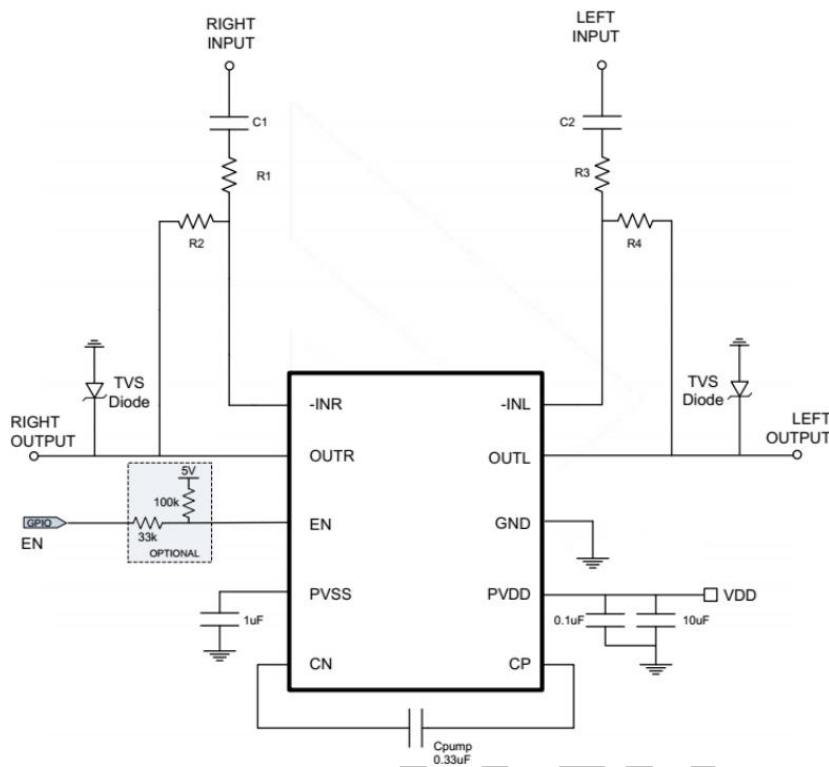
THD+N vs. Output Voltage

THD+N vs. Output Voltage

THD+N vs. Frequency

THD+N vs. Frequency

Typical Characteristics (continued)
 $T_A=25^{\circ}\text{C}$, $V_{DD}=3.3\text{V}$, unless otherwise noted

Application Circuit

Differential-input, single-ended output, second-order filter $R1=R3=15k\Omega$, $R2=R4=30k\Omega$, $C1=C2=33pF$, $R11=5.6k\Omega$, $R12=2.43k\Omega$, $R13=15k\Omega$, $Cpvss=0.33$ to $1\mu F$, $Cpump=0.33$ to $1\mu F$.

Notes

1. In some applications, if the power supply noise needs to be filtered, the ferrite bead is recommended in a value of $600\text{ohm}@100\text{MHz}$, instead of RC network. RC network normally will lower the power supply resulting in the degraded the audio performance. If the resistor is not chosen properly, which can trigger the internal UVP detection circuit and shut down the output, as depicted below.

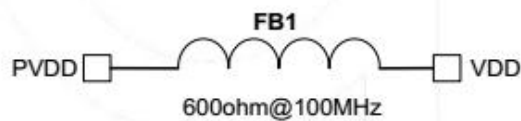

2. In order to protect the device against the power surge, transient voltage suppressor (TVS) devices are recommended at the output pins OUTL/OUTR.

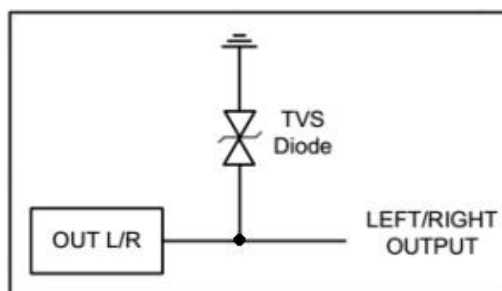

Application Notes

Gain-Setting Resistors Ranges and Input-Blocking Capacitors

The gain-setting resistors, R_{IN} and R_{FB} , must be chosen so that noise, stability, and input capacitor size of the WS74607 are kept within acceptable limits. Voltage gain is defined as R_{FB} divided by R_{IN} . Table 1 lists the recommended resistor value for different gain settings. Selecting values that are too low demands a large input ac-coupling capacitor C_{IN} . Selecting values that are too high increases the noise of the amplifier. The gain-setting resistor must be placed close to the input pins to minimize capacitive loading on these input pins and to ensure maximum stability.

Table 1. Input Capacitor with 2Hz cutoff and Resistor Values Recommended

Input Res., R_{IN}	Feedback Res., R_{fb}	Inverting Gain
22 k Ω	22 k Ω	-1 V/V
15 k Ω	30 k Ω	-2 V/V
10 k Ω	100 k Ω	-10 V/V

$$f_{CIN} = \frac{1}{2\pi R_{IN} C_{IN}} \text{ or}$$

$$C_{IN} = \frac{1}{2\pi R_{IN} f_{CIN}}$$

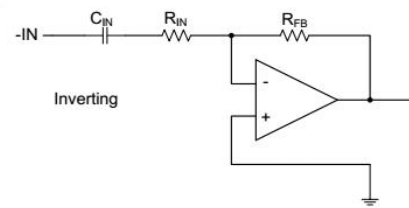

Equation 1. Cutoff decision Cutoff

Figure 2. Non-Inverting Gain Configuration

INPUT-BLOCKING CAPACITORS

DC input-blocking capacitors are required to be added in series with the audio signal into the input pins of WS74607. These capacitors block the dc portion of the audio source and allow WS74607 inputs to be properly biased to provide maximum performance. These capacitors form a high-pass filter with the input resistor, R_{IN} . The cutoff frequency is calculated using the equation below. For this calculation, the capacitance used is the input-blocking capacitor, and the resistance is the input resistor chosen from Table 1; then the frequency and/or capacitance can be determined when one of the two values is given.

2nd Order Filter Typical Application

Several audio DACs used today require an external low-pass filter to remove out-of-band noise. This is possible with the WS74607, as it can be used like an inverting OPAMP. Several filter topologies can be implemented, just like single-ended. In Figure 3, a multi-feedback (MFB) with single-ended input is shown. An ac-coupling capacitor to remove dc content from the source is shown; it serves to block any dc content from the source and lowers the dc-gain to 1, helping reduce the output dc-offset to minimum. The resistor values should have a low value for obtaining low noise, but should also have a high enough value to get a small size ac-coupling capacitor.

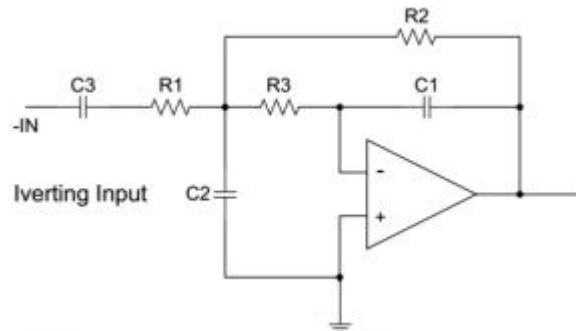

Figure 3. Second-Order Active Low-Pass Filter

Charge Pump Flying Capacitor and PVSS Capacitor

The charge pump flying capacitor serves to transfer charge during the generation of the negative supply voltage. The PVSS capacitor must be at least equal to the charge pump capacitor in order to allow maximum charge transfer. Low ESR X5R or X7R capacitors are recommended selection, a value of typical $0.33\mu\text{F}$ is recommended for C_{PUMP} , and a value of typical $1\mu\text{F}$ is recommended for PVSS. Capacitor values can be smaller than the value recommended, but the maximum output voltage may be reduced and the device may not operate to specifications.

Decoupling Capacitors

The WS74607 requires adequate power supply decoupling to ensure that the noise and total harmonic distortion (THD) are low. A good low equivalent-series-resistance (ESR) X5R or X7R ceramic capacitor, typically a combine of paralleled $0.1\mu\text{F}$ and $10\mu\text{F}$, placed as close as possible to the device VDD lead works best. Placing this decoupling capacitor close to the WS74607 is important for the performance of the amplifier. For filtering lower-frequency noise signals, a $10\mu\text{F}$ or greater capacitor placed near the audio power amplifier would also help, but it is not required in most applications because of the high PSRR of this device.

Pop-Free Power-Up

Pop-free power up is ensured by keeping the EN (shut down pin) low during power-supply ramp up and ramp down. The EN pin should be kept low until the input ac-coupling capacitors are fully charged before asserting the EN pin high to achieve pop-less power up. Figure 6 illustrates the preferred sequence.

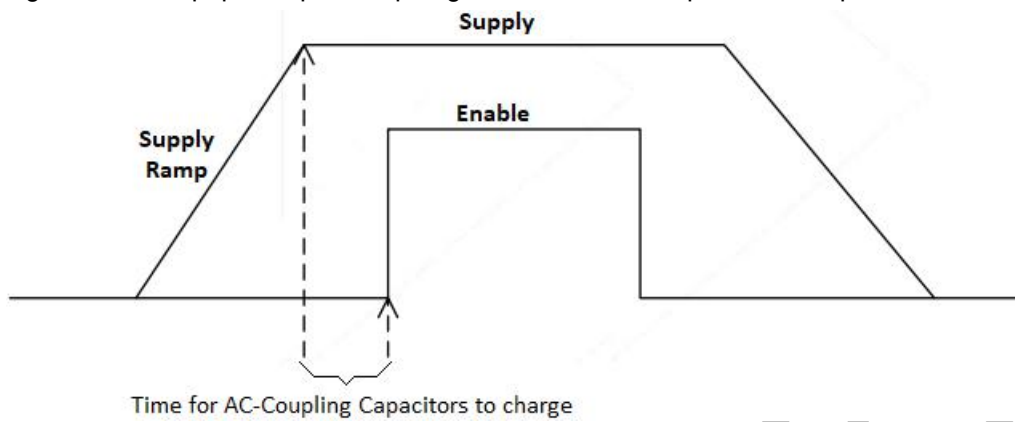
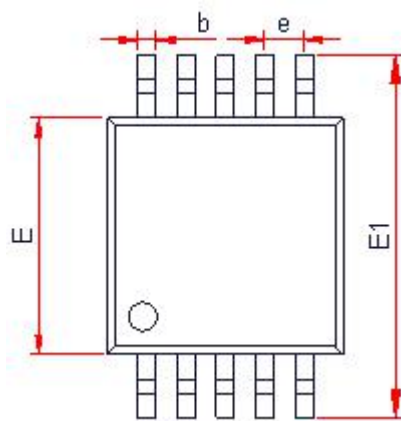
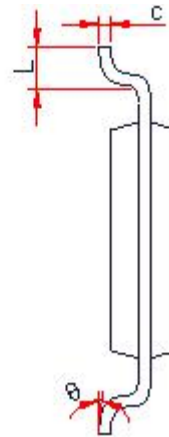
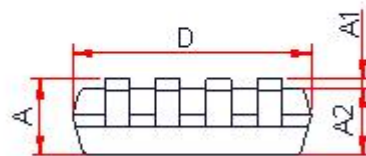

Figure 4. Power-Up Sequences

Capacitive Load

The WS74607 has the ability to drive a high capacitive load up to 220pF directly. Higher capacitive loads can be accepted by adding a series resistor of 47Ω or larger.

PRELIMINARY

PACKAGE OUTLINE DIMENSIONS
MSOP-10L

TOP VIEW

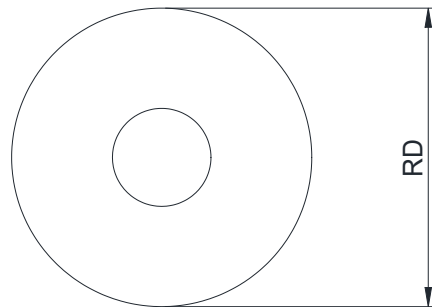
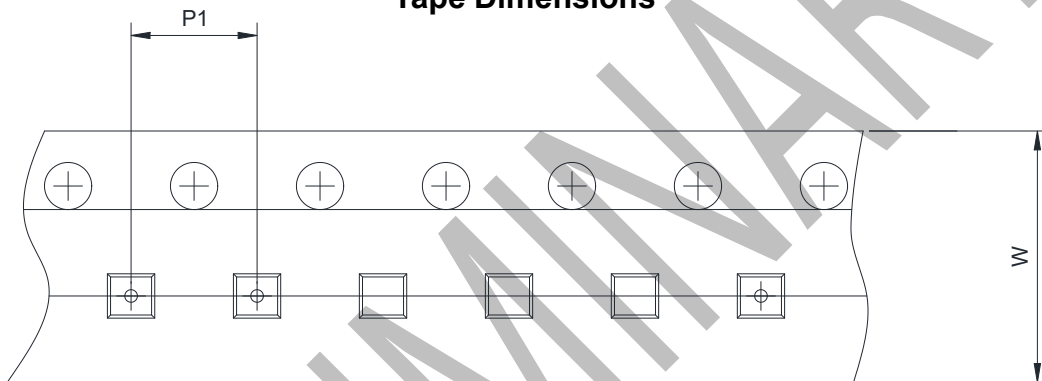
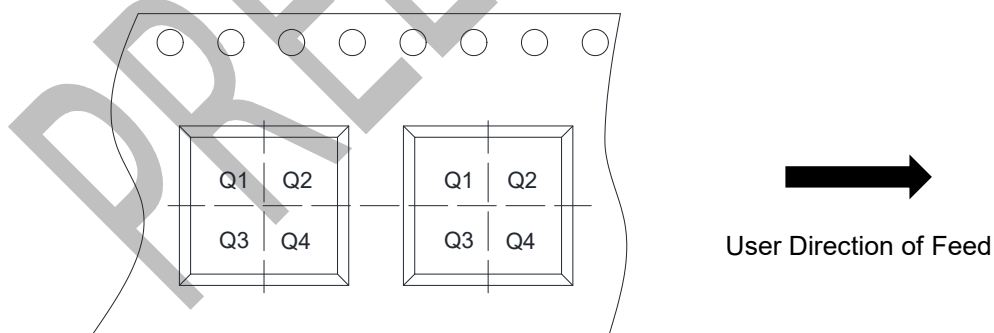
SIDE VIEW

SIDE VIEW

Symbol	Dimensions In Millimeters (mm)		
	Min.	Typ.	Max.
A	-	-	1.10
A1	0.05	-	0.15
A2	0.75	0.85	0.95
b	0.17	-	0.27
c	0.08	0.15	0.23
D	2.90	3.00	3.10
E1	4.70	4.90	5.10
E	2.90	3.00	3.10
e	0.50 BSC		
L	0.40	0.6	0.80
θ	0°	-	8°

TAPE AND REEL INFORMATION
Reel Dimensions

Tape Dimensions

Quadrant Assignments For PIN1 Orientation In Tape

RD	Reel Dimension	<input type="checkbox"/> 7inch	<input checked="" type="checkbox"/> 13inch		
W	Overall width of the carrier tape	<input type="checkbox"/> 8mm	<input checked="" type="checkbox"/> 12mm		
P1	Pitch between successive cavity centers	<input type="checkbox"/> 2mm	<input type="checkbox"/> 4mm	<input checked="" type="checkbox"/> 8mm	
Pin1	Pin1 Quadrant	<input checked="" type="checkbox"/> Q1	<input type="checkbox"/> Q2	<input type="checkbox"/> Q3	<input type="checkbox"/> Q4

X-ON Electronics

Largest Supplier of Electrical and Electronic Components

Click to view similar products for [Gate Drivers](#) category:

Click to view products by [Will Semiconductor](#) manufacturer:

Other Similar products are found below :

[00028](#) [00053P0231](#) [56956](#) [57.404.7355.5](#) [LT4936](#) [57.904.0755.0](#) [5811-0902](#) [5882900001](#) [00600P0005](#) [00-9050-LRPP](#) [00-9090-RDPP](#)
[5951900000](#) [0131700000](#) [00-2240](#) [LTP70N06](#) [LVP640](#) [5J0-1000LG-SIL](#) [LY2-US-AC240](#) [LY3-UA-DC24](#) [00576P0020](#) [00600P0010](#)
[LZN4-UA-DC12](#) [LZNQ2M-US-DC5](#) [LZNQ2-US-DC12](#) [LZP40N10](#) [00-8196-RDPP](#) [00-8274-RDPP](#) [00-8275-RDNP](#) [00-8609-RDPP](#) [00-](#)
[8722-RDPP](#) [00-8728-WHPP](#) [00-8869-RDPP](#) [00-9051-RDPP](#) [00-9091-LRPP](#) [00-9291-RDPP](#) [0207100000](#) [0207400000](#) [60100564](#) [60249-1-](#)
[CUT-TAPE](#) [0134220000](#) [60713816](#) [M15730061](#) [61161-90](#) [61278-0020](#) [6131-204-23149P](#) [6131-205-17149P](#) [6131-209-15149P](#) [6131-218-](#)
[17149P](#) [6131-220-21149P](#) [6131-260-2358P](#)