



承 认 书

APPROVAL SHEETS

客户名称 CUSTOMER	
客户料号 MODEL NO	
产品名称 PART NAME	10/100 BASE-T Single Port Transformer Modules
产品型号 PART TYPE	HX1631SR
版 本 REV	A01
客户承认 CUSTOMER APPROVAL	承认印： SIGNET 签名： SIGNATURE

深圳市威勤电子技术有限公司

ShenZhen Winchen Electronic Technolgy Co.,Ltd

地址：深圳市南山区留仙大道4093号南山云谷创新产业园山水楼B座4楼

Tel: 0755-83576361 Fax: 0755-83047459

E-mail : alan@winchen.com.cn

10/100BASE-TX TRANSFORMER MODULES

Features:

- IEEE 802.3 AT PoE /ANSI X3.263 compliant performance.
- 720mA current capability for POE product
- Storage temperature range: -40~+80°C,90%RH
- RoHS compliant

Specifications

Electrical Specification@25°C Operating Temperature -40 to +85°C							
Part NO	Trun Ratio (±3%)		OCL primary@ 100KHz,0.1Vrms,15mA	Leakage primary@ 100KHz,0.1Vrms	Cww (Pri.:Sec.)	DCR (Ω)	
	TX	RX				Primary	Secondary
HX1631SR	1CT:1CT	1CT:1CT	350uH Min	0.5uH max	35pF Max	0.9 Max	1.2 Max

Electrical Specification@25°C Operating Temperature -40 to +85°C									
Part NO	Insertion loss (dB max) 1-100MHz	Return loss(dB min) MHz				DMRR (dB min .) MHz		Crosstalk (dB min .) MHz	Isolation Voltage (Vrms min)
		1-30	40	50	60-100	1-60	60-100		
HX1631SR	-1.0	-18	-16	-16	-10	-35	-30	-33	1500

Dimension Unless otherwise specified, all tolerances are ±0.25mm

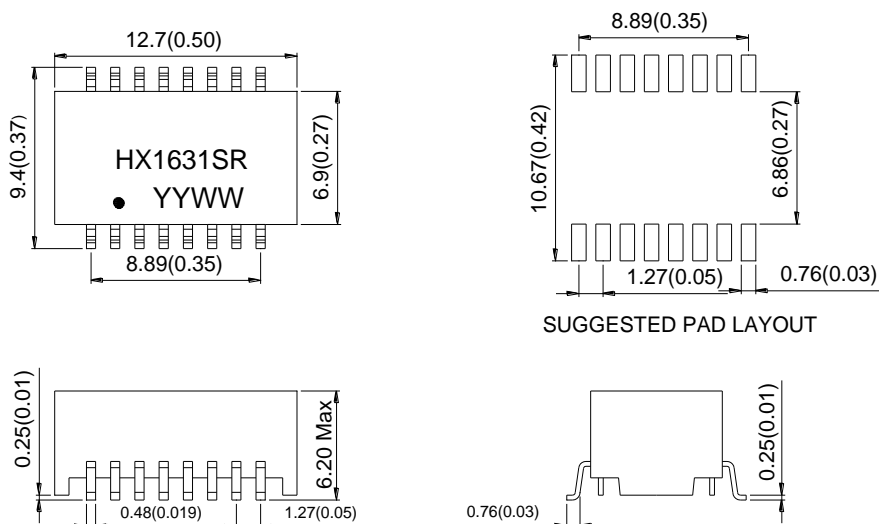

Schematic

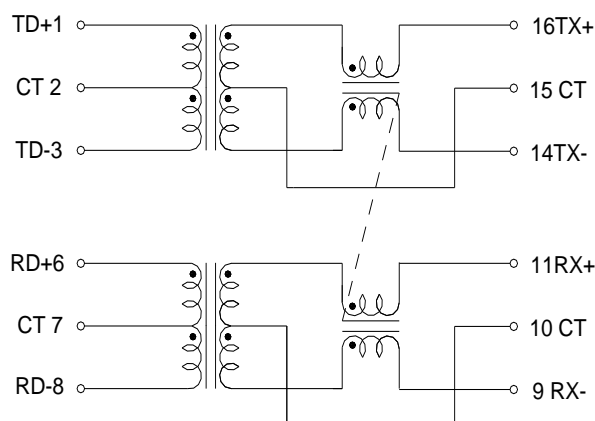

5.SUGGEST PROFILE

IR reflow graph

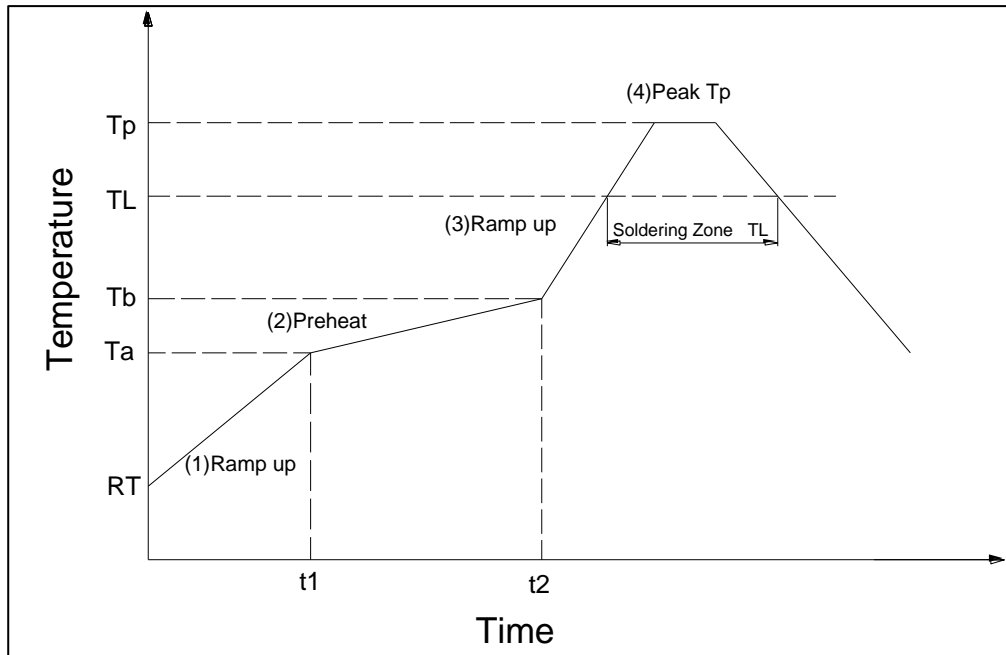

IR reflow profile

Form-1 (Reference JEDEC J-STD-020C Table 5-2))

IR reflow profile		Sn-Pb	Pb-free
step#	Profile Feature	Condition/Duration	Condition/Duration
step1	Ramp-up rate	1.5-3°C/sec.	1.5-3°C/sec.
step2	Preheat : 100~150°C (Ta-Tb)	t1-t2 : 60~120 sec.	t1-t2 : 60~180 sec.
step3	Ramp-up rate(T _L to T _P)	1.5-3°C/sec.	1.5-3°C/sec.
	Temperature maintained above 183°C(T _L)	T _L : 60-150sec.	T _L : 80-150sec.
step4	Peak temperature(T _P)	230+5/-10°C	260+0/-5°C
	Time within 5°C of actual peak temperature	30±10 sec.	30±10 sec.
step5	Ramp-down rate	6°C/sec.Max	6°C/sec.Max
Note1	Subject the samples to 3 cycles of the above defined reflow conditions		Subject the samples to 3 cycles of the above defined reflow conditions
Note2	Time 25°C to peak temperature : 6 minutes max.		Time 25°C to peak temperature : 8 minutes max.
Note3			The time between reflows shall be 5 minutes minimum and 60minutes maximum

SnPb Eutectic Process- "Package Peak Reflow Temperature"

Form-2 (Reference JEDEC J-STD-020C Table 4-1)

产品厚度	产品体积 < 350mm ³	产品体积 ≥ 350mm ³
< 2.5mm	240 +0/-5°C	225 +0/-5°C
≥ 2.5mm	225 +0/-5°C	225 +0/-5°C

Pb-free Process - "Package Peak Reflow Temperature"

Form-3 (Reference JEDEC J-STD-020C Table 4-2)

产品厚度	产品体积 < 350mm ³	产品体积 350mm ³ -2000mm ³	产品体积 ≥ 2000mm ³
< 1.6mm	260 +0/-5°C	260 +0/-5°C	260 +0/-5°C
1.6mm-2.5mm	260 +0/-5°C	250 +0/-5°C	245 +0/-5°C
> 2.5mm	250 +0/-5°C	245 +0/-5°C	245 +0/-5°C



ShenZhen Winchen Electronic Technology Co.,Ltd

REV: 01

深圳市威勤电子技术有限公司

Page: 3 of 6

6. Reliability

No.	Test Item	Refer To Standard	Test Condition																					
1	Resistance To Soldering Heat--Convection Reflow	IPC/JEDEC J-STD-020D	1).Peak Temperature: Refer to Specification According to Package Body Thickness And Volume 2).Preheat Temperature and Soak Time: 150~200°C,60~120 Seconds 3).Average Ramp-up Rate: 3°C/Second Max 4).Above 217°C: 60~150 Seconds 5).Peak Temperature-5°C: Over 30 S																					
2	Thermal Shock	IEC68-2-14 Method A	1.Low Temperature:-40°C 2.High Temperature:125 3.Dwell Time:30 Minutes 4.Transition Time: Less Than 5Minutes 5.Number of Cycles: 10																					
3	High Temperature	IEC68-2-2 Method A	125°C ,96Hours																					
4	Low Temperature	IEC68-2-1 Method A	-40°C ,96Hours																					
5	Temperature Humidity Cycle	IEC68-2-38	<table border="1"> <thead> <tr> <th>Temp</th> <th>Humidity</th> <th>soak time</th> </tr> </thead> <tbody> <tr> <td>25~65°C</td> <td>93+/-3%RH</td> <td>1.5 hr</td> </tr> <tr> <td>65°C</td> <td>93+/-3%RH</td> <td>4 hr</td> </tr> <tr> <td>65~25°C</td> <td>80~96%RH</td> <td>2.5 hr</td> </tr> <tr> <td>25~65°C</td> <td>93+/-3%RH</td> <td>1.5hr</td> </tr> <tr> <td>65°C</td> <td>93+/-3%RH</td> <td>4hr</td> </tr> <tr> <td>65~25°C</td> <td>80~96%RH</td> <td>2</td> </tr> </tbody> </table>	Temp	Humidity	soak time	25~65°C	93+/-3%RH	1.5 hr	65°C	93+/-3%RH	4 hr	65~25°C	80~96%RH	2.5 hr	25~65°C	93+/-3%RH	1.5hr	65°C	93+/-3%RH	4hr	65~25°C	80~96%RH	2
Temp	Humidity	soak time																						
25~65°C	93+/-3%RH	1.5 hr																						
65°C	93+/-3%RH	4 hr																						
65~25°C	80~96%RH	2.5 hr																						
25~65°C	93+/-3%RH	1.5hr																						
65°C	93+/-3%RH	4hr																						
65~25°C	80~96%RH	2																						
6	Vibration	IEC68-2-6	1.Sine Wave 2.Amplitude:0.75mm 3.Frequence:5~500~5Hz 4.Direction: X,Y,Z 5.Number of Sweep Cycles Per Direction:10 6.Duration: 2 Hours Each Direction																					
7	Mechanical Shock	MIL-STD-202	1).Half -Sine Wave 2).Peak Acceleration:50G 3).Duration:11mS 4).Direction: X,Y,Z,-X,-Y,-Z 5).Number of Shock Per Direction:3																					
8	Free Drop	ISO4180	1) Height: Refer to Specification According to Production weight 2).1Corner,3Edges,6Faces .Total Are 10 Times																					
9	Solderability	JESD22-B102D	1).Precondition:150±5°C,16±0.5Hours 2).Flux Type:ROL1 3).Immersion Flux Time: 5~10 Seconds 4).Solder Temperature:245±5°C 5).Solder Immersion Time:5±0.5 Seconds 6).Solder Immersion/Emersion Speed:25.4±6.4mm/Second																					
10	Accelerated Moisture Resistance---Unbiased Autoclave	JESD22-A102-C	1.Temperature:121°C 2. Humidity: 100% 3. Vapor Pressure: 29.7 Psia or 205KPa 4.Duration:96 hours																					



SMD PARTS PIN 脚吃锡性检验规范

- 1.适用范围：含所有 SMD PARTS 吃锡性之检验
- 2.检验方法：
 - A.照 AQL 方式取样
 - B.采用自然目视检测：沾锡后利用反光看其吃锡面是否良好及有否发黑，氧化等之不良现象。
 - C.若有进一步分析检测必要时于每一 LOT 取 5 PCS SAMPLE 再做下列 TEST：
 - a.利用 50 倍显微镜，测看其吃锡面是否良好规格需达 90%以上。
 - b.检验其针孔需小于 3 个以下。
 - D.焊锡性实验：以实际的印刷电路，印上锡膏，再放置 SMD 零件。过回

PIN SOLDERBILITY TEST

1. Soldering Material:
 - A. Tin: PIN=Sn/Ag/ Cu
 - B. Flux: R Type Flux
2. Random sampling 5 pcs for each lot to do tolerability test, and make sure
 - A. Soldering surface should be covered over 90%
 - B. Un-covered small pin hold should be less tha

环保情况说明

- 产品符合 RoHS 2002-95-EC 指令
- 不含有 RoHS 禁止的 Pb-Cd-Hg-Cr6+-PBB-PBDE 六种有害
- 我司检验 RoHS 物质是根据 IEC-62321 方法进行混测的
- 产品有害物质标准如下：
 - Pb 铅 \leq 1000 PPM
 - Hg 汞 \leq 1000 PPM
 - Cd 镉 \leq 100 PPM
 - Cr+6 六价铬 \leq 1000 PPM
 - PBB 多溴联苯 \leq 1000 PPM
 - PBDE 多溴二苯醚 \leq 1000 PPM

Environmental statement

- Compliant with RoHS Directive.
- Free from Pb- Cd-Hg-Cr6+-PBB-PBDE that banned in the RoHS Directive
- We will inspect the Restricted hazardous substance with component mixture according to the criteria of IEC-62321
- The directives for prohibited substances is as follows :
 - Pb \leq 1000 PPM
 - Hg \leq 1000 PPM
 - Cd \leq 100 PPM
 - Cr+6 \leq 1000 PPM
 - PBB \leq 1000 PPM
 - PBDE \leq 1000 PPM

产品储存条件说明底（座类产品）

1. 未拆真空包装储存条件： 温度： \leq 30℃湿度： \leq 60%RH
2. 保存期限： 1 年。
3. 产品在超过保存期限还未使用，建议在使用前先检查PIN脚是否氧化，如有氧化现象建议重新镀锡再使用。



WINCHEN

ShenZhen Winchen Electronic Technolgy Co.,Ltd

深圳市威勤电子技术有限公司

REV: 01

Page: 5 of 6

7 CARRIER TAPE

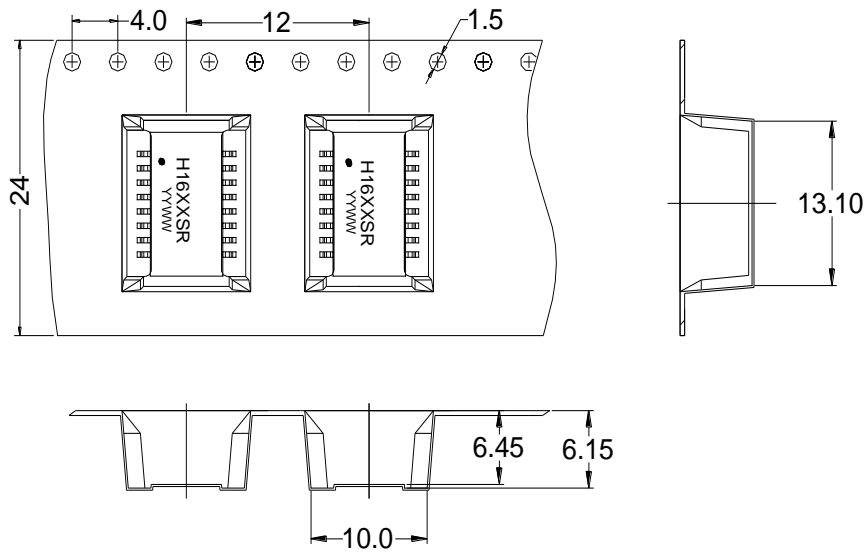

8 PACKAGE

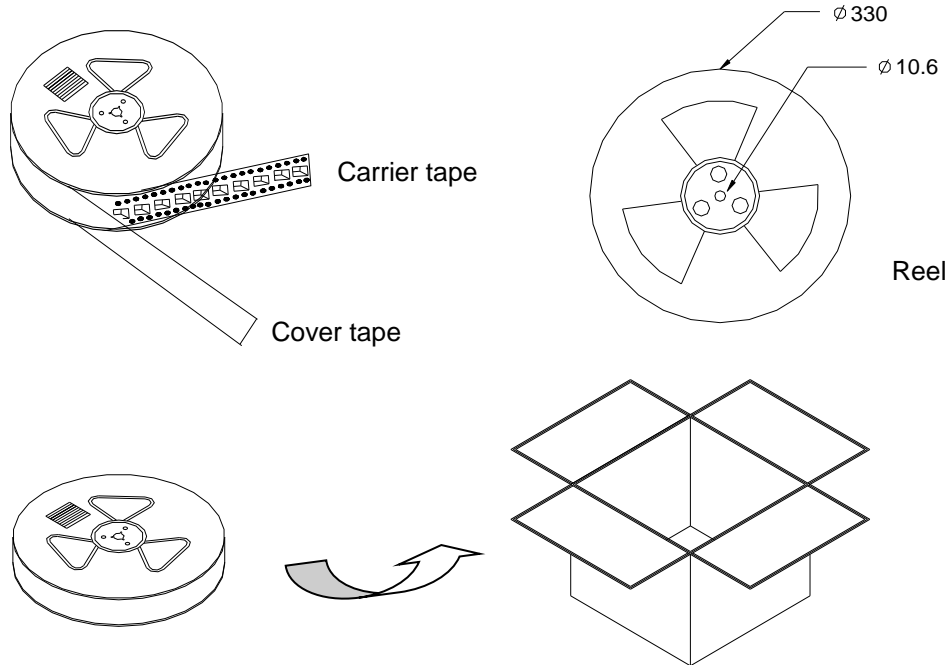

Product	PCS/Reel	PCS/Box	Product No.	Weigh(g/pcs)
SMD 16PIN(1.27x9.55) Series	750	750x6=4500	HX1631SR	0.8



WINCHEN

ShenZhen Winchen Electronic Technolgy Co.,Ltd

深圳市威勤电子技术有限公司

REV: 01

Page: 6 of 6

X-ON Electronics

Largest Supplier of Electrical and Electronic Components

Click to view similar products for [Audio Transformers](#) / [Signal Transformers](#) category:

Click to view products by [Winchen](#) manufacturer:

Other Similar products are found below :

[CU4S0506AT-2655-H1](#) [MGPWT-00449-P](#) [PE-64961](#) [1812WBT2-4](#) [BX1194WNL](#) [1879479-1](#) [PA1528ANL](#) [T1137NLT](#) [T3012NL](#) [PE-65848FNLT](#) [H5019EFNL](#) [CX2045ALNLT](#) [MET-14](#) [MGPWT-00059-P](#) [MGPWT-00266-P](#) [MGPWT-00278-P](#) [MGPWT-00431-P](#) [TTC-100](#) [TTC-143-H](#) [TTC-5032-1](#) [4-1879391-0](#) [100213](#) [T1142NL](#) [T1124NL](#) [1879732-1](#) [2-1879391-5](#) [B8846NL](#) [MABA-010321-CT1A42](#) [TX1341NL](#) [H0013FNL](#) [H5020FNL](#) [H2009FNLT](#) [H5004NLT](#) [S553-5999-52-F](#) [T5008NLT](#) [PE-68517T](#) [TG111-E212NWLFR](#) [MGPWT-00339-P](#) [H5014FNLT](#) [TX1473NLT](#) [PE-69011NLT](#) [CX2043LNLT](#) [H7137FNLT](#) [H1259NLT](#) [TX1344NLT](#) [LM-LP-1005L](#) [H0013NLT](#) [S558-5500-JV](#) [TX1193NLT](#) [T7015NL](#)