

General Description

The WSD28N10DN33 is the highest performance N-Channel MOSFET with extreme high cell density, which provide excellent $R_{DS(ON)}$ and gate charge for most of the synchronous buck converter applications.

The WSD28N10DN33 meet the RoHS and Green Product requirement 100% E_{AS} guaranteed with full function reliability approved.

Features

- 100% UIS + Rg Tested
- Reliable and Rugged
- Lead Free and Green Devices Available

Product Summary

BV_{DSS}	$R_{DS(ON)}$	I_D
100V	45mΩ	25A

Applications

- Power Management in DC/DC Converter.
- POE Protection Switch.

DFN3X3-8L Pin Configuration

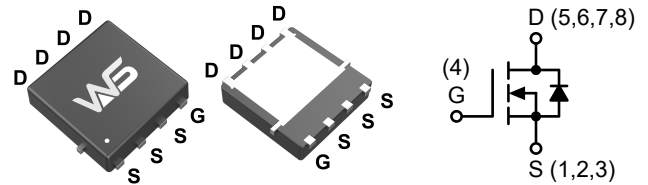

5 Vgc`i H`A U ja i a `FUHb[gÁV_MG »ÓÁM, |^••ÁU@!, ã^Á[c^áD

Symbol	Parameter	Rating	Units
V_{DS}	Drain-Source Voltage	100	V
V_{GS}	Gate-Source Voltage	± 20	
$I_D@T_C=25^\circ C$	Continuous Drain Current	25	A
$I_D@T_C=100^\circ C$		15.5	
I_{DM}^a	Pulsed Drain Current, $T_C=25^\circ C$	75	
E_{AS}^b	Avalanche Energy, Single pulse, $L=0.5mH$	16	mJ
I_{AS}^b	Avalanche Current, Single pulse, $L=0.5mH$	8	A
$P_D@T_C=25^\circ C$	Total Power Dissipation	25	W
$P_D@T_C=100^\circ C$		10	
T_{STG}	Storage Temperature Range	-55 to 150	$^\circ C$
T_J	Operating Junction Temperature Range	-55 to 150	

Thermal Data

Symbol	Parameter	Typ.	Max.	Unit
$R_{\theta JA}^c$	Thermal Resistance Junction-Ambient	---	80	$^\circ C/W$
$R_{\theta JC}$	Thermal Resistance Junction-Case	---	5	$^\circ C/W$

Note a : Pulse width limited by maximum junction temperature.

Note b : UIS tested and pulse width limited by maximum junction temperature $150^\circ C$ (initial temperature $T_j=25^\circ C$).

Note c : Surface Mounted on $1in^2$ pad area.

Electrical Characteristics ($T_A = 25^\circ\text{C}$, unless otherwise noted)

Symbol	Parameter	Conditions	Min.	Typ.	Max.	Unit
BV_{DSS}	Drain-Source Breakdown Voltage	$V_{GS}=0V, I_D=250\mu A$	100	---	---	V
$R_{DS(ON)}$	Static Drain-Source On-Resistance ^d	$V_{GS}=10V, I_{DS}=7A$	---	45	54	$m\Omega$
		$V_{GS}=4.5V, I_{DS}=7A$	---	55	70	$m\Omega$
$V_{GS(th)}$	Gate Threshold Voltage	$V_{GS}=V_{DS}, I_D=250\mu A$	1.0	1.7	2.5	V
I_{DSS}	Drain-Source Leakage Current	$V_{DS}=80V, V_{GS}=0V, T_J=25^\circ\text{C}$	---	---	1	μA
		$V_{DS}=80V, V_{GS}=0V, T_J=85^\circ\text{C}$	---	---	30	
I_{GSS}	Gate-Source Leakage Current	$V_{GS}=\pm 20V, V_{DS}=0V$	---	---	± 100	nA
R_G	Gate Resistance	$V_{DS}=0V, V_{GS}=0V, f=1\text{MHz}$	---	1.5	---	Ω
Q_g	Total Gate Charge	$V_{DS}=50V, V_{GS}=10V, I_{DS}=7A$	---	7.5	11	nC
Q_{gs}	Gate-Source Charge		---	2.2	---	
Q_{gd}	Gate-Drain Charge		---	1.6	---	
$T_{d(on)}$	Turn-On Delay Time	$V_{DD}=30V, R_L=30\Omega, I_{DS}=1A, V_{GEN}=10V, R_G=6\Omega$	---	6	11	ns
T_r	Rise Time		---	9	17	
$T_{d(off)}$	Turn-Off Delay Time		---	12	22	
T_f	Fall Time		---	14	26	
C_{iss}	Input Capacitance	$V_{DS}=15V, V_{GS}=0V, f=1\text{MHz}$	---	2116	---	pF
C_{oss}	Output Capacitance		---	117	---	
C_{rss}	Reverse Transfer Capacitance		---	97	---	

Diode Characteristics

Symbol	Parameter	Conditions	Min.	Typ.	Max.	Unit
I_S	Continuous Source Current	$V_G=V_D=0V$, Force Current	---	---	25	A
V_{SD}	Diode Forward Voltage ^d	$V_{GS}=0V, I_S=7A$	---	0.8	1.3	V
t_{rr}	Reverse Recovery Time	$I_F=7A, dI/dt=100A/\mu s$	---	30	---	nS
Q_{rr}	Reverse Recovery Charge		---	40	---	nC

Note d : Pulse test ; pulse width $\leq 300\mu s$, duty cycle $\leq 2\%$.

Note e : Guaranteed by design, not subject to production testing.

Typical Characteristics

Power Dissipation

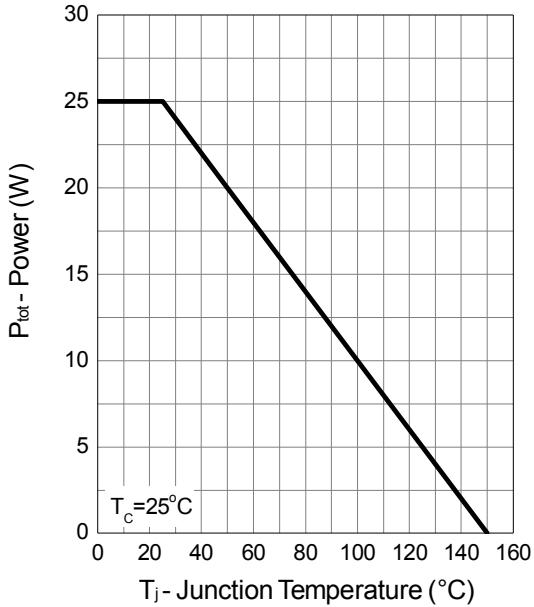

Drain Current

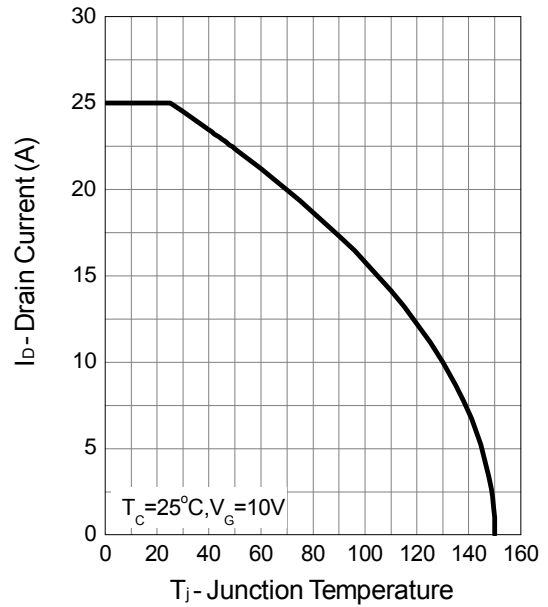

Safe Operation Area

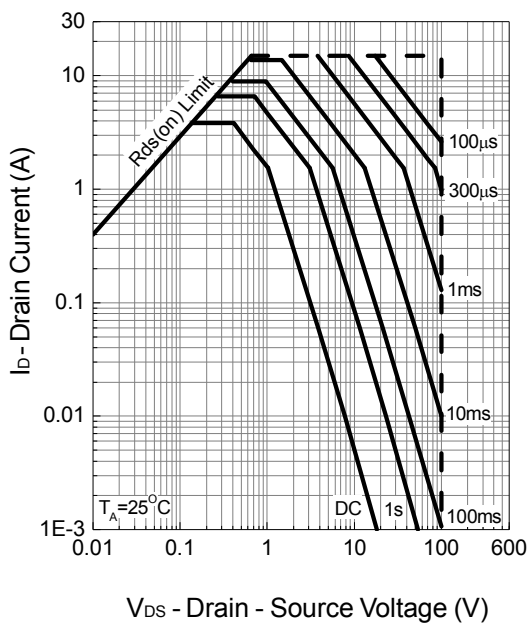

Thermal Transient Impedance

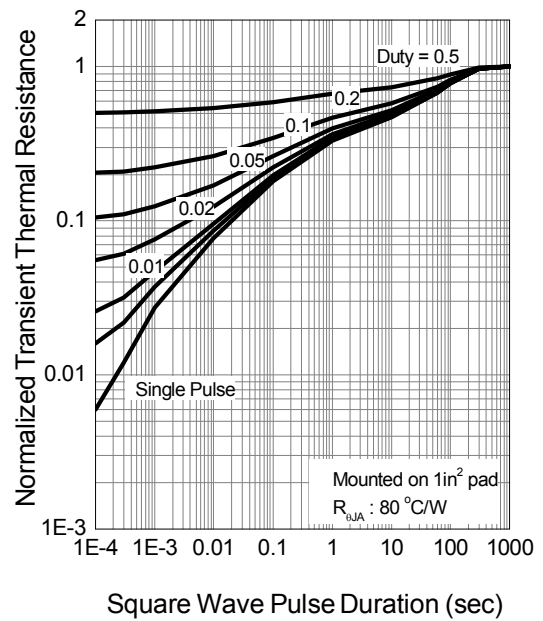

Typical Characteristics (Cont.)

Gate-Source On Resistance

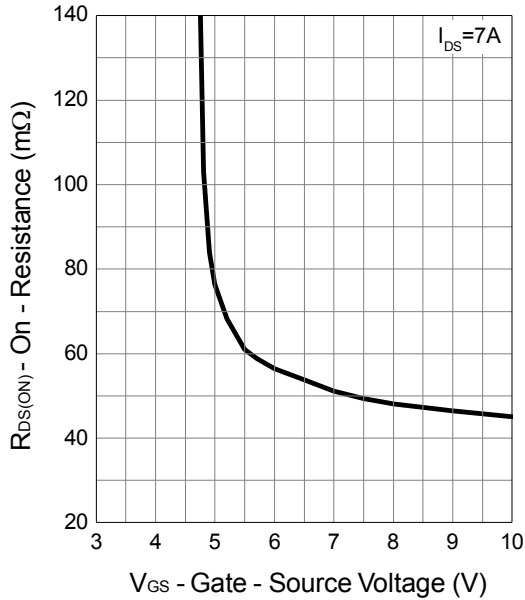

Gate Threshold Voltage

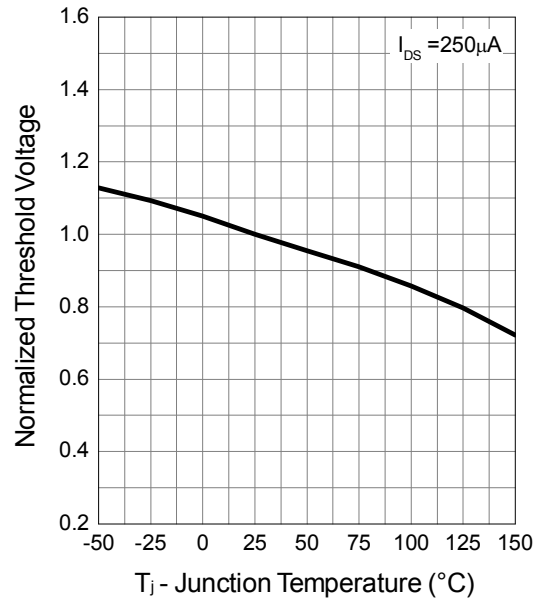

Output Characteristics

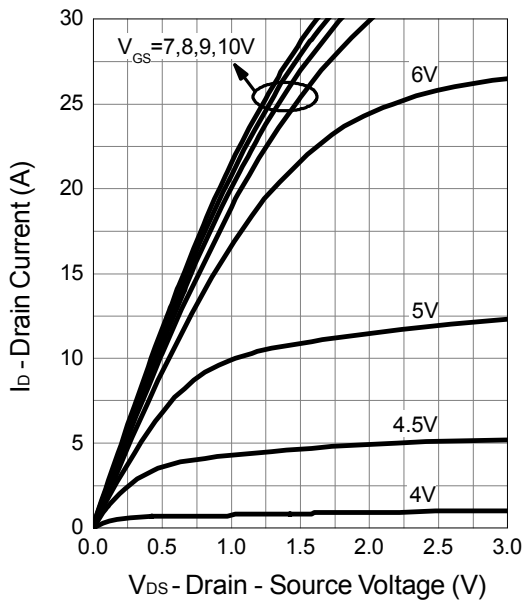

Drain-Source On Resistance

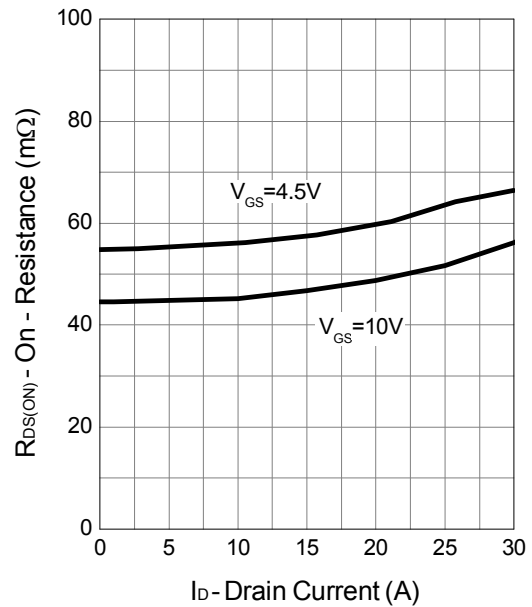

Typical Characteristics (Cont.)

Capacitance

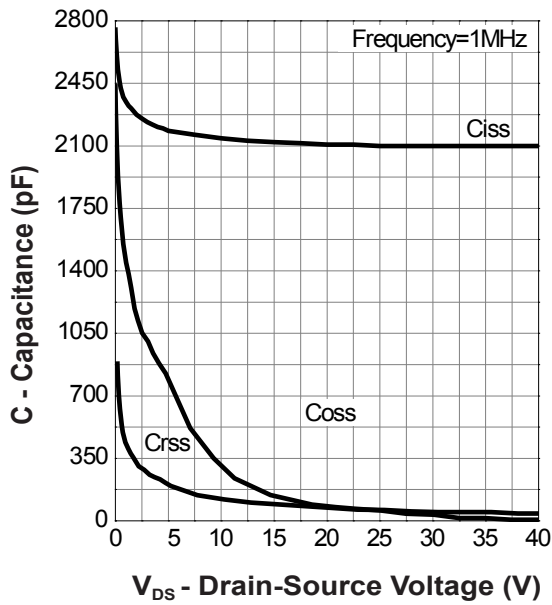

Gate Charge

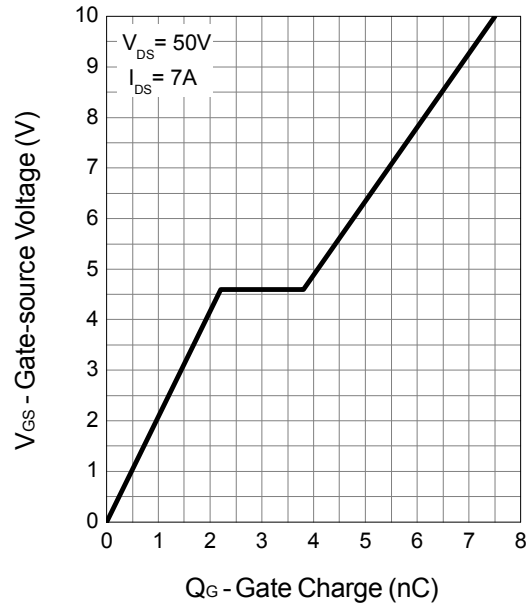

Drain-Source On Resistance

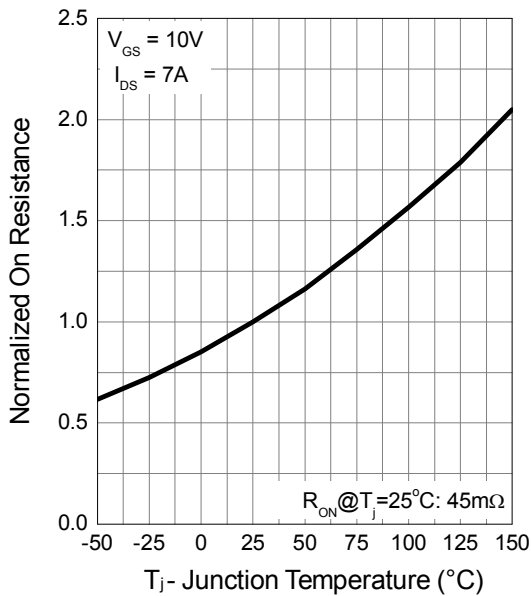

Source-Drain Diode Forward

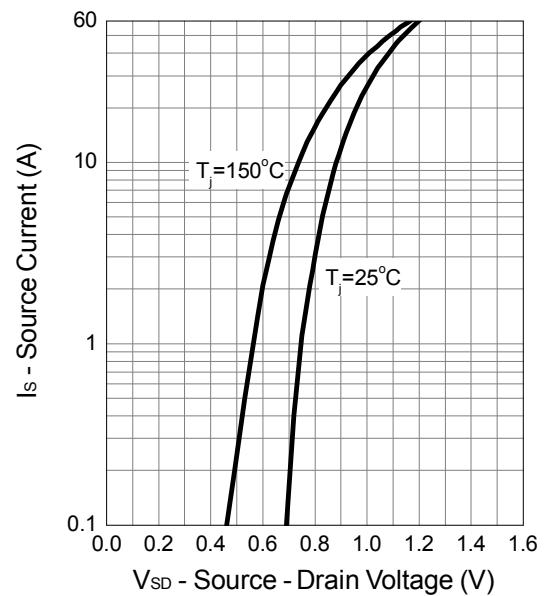

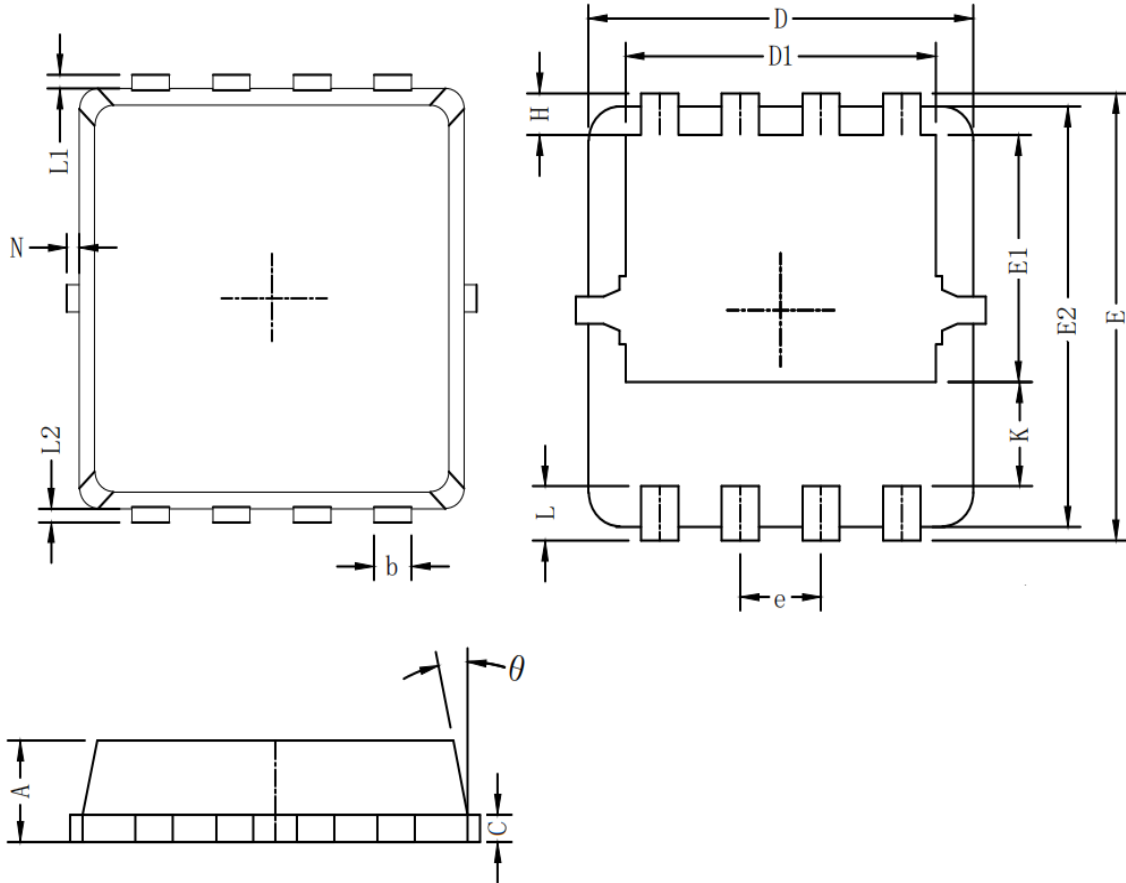
Packaging information

Symbol	Dim in mm		
	min	typ	max
A	0.6	0.75	0.9
b	0.2	0.3	0.4
C	0.15	0.2	0.25
D	3	3.1	3.2
D1	2.3	2.45	2.6
E	3.15	3.3	3.45
E1	1.43	1.73	1.93
E2	2.9	3.05	3.2
e	0.65BSC		
H	0.2	0.35	0.5
K	0.57	0.77	0.87
L	0.3	0.4	0.5
L1/L2	0.1REF		
θ	8°	10°	13°
N	0		0.15



Attention

- 1, Any and all Winsok power products described or contained herein do not have specifications that can handle applications that require extremely high levels of reliability, such as life-support systems, aircraft's control systems, or other applications whose failure can be reasonably expected to result in serious physical and/or material damage. Consult with your Winsok power representative nearest you before using any Winsok power products described or contained herein in such applications.
- 2, Winsok power assumes no responsibility for equipment failures that result from using products at values that exceed, even momentarily, rated values (such as maximum ratings, operating condition ranges, or other parameters) listed in products specifications of any and all Winsok power products described or contained herein.
- 3, Specifications of any and all Winsok power products described or contained herein stipulate the performance, characteristics, and functions of the described products in the independent state, and are not guarantees of the performance, characteristics, and functions of the described products as mounted in the customer's products or equipment. To verify symptoms and states that cannot be evaluated in an independent device, the customer should always evaluate and test devices mounted in the customer's products or equipment.
- 4, Winsok power Semiconductor CO., LTD. strives to supply high-quality high-reliability products. However, any and all semiconductor products fail with some probability. It is possible that these probabilistic failures could give rise to accidents or events that could endanger human lives that could give rise to smoke or fire, or that could cause damage to other property. When designing equipment, adopt safety measures so that these kinds of accidents or events cannot occur. Such measures include but are not limited to protective circuits and error prevention circuits for safe design, redundant design, and structural design.
- 5, In the event that any or all Winsok power products (including technical data, services) described or contained herein are controlled under any of applicable local export control laws and regulations, such products must not be exported without obtaining the export license from the authorities concerned in accordance with the above law.
- 6, No part of this publication may be reproduced or transmitted in any form or by any means, electronic or mechanical, including photocopying and recording, or any information storage or retrieval system, or otherwise, without the prior written permission of Winsok power Semiconductor CO., LTD.
- 7, Information (including circuit diagrams and circuit parameters) herein is for example only; it is not guaranteed for volume production. Winsok power believes information herein is accurate and reliable, but no guarantees are made or implied regarding its use or any infringements of intellectual property rights or other rights of third parties.
- 8, Any and all information described or contained herein are subject to change without notice due to product/technology improvement, etc. When designing equipment, refer to the "Delivery Specification" for the Winsok power product that you intend to use.
- 9, this catalog provides information as of Sep. 2014. Specifications and information herein are subject to change without notice.

X-ON Electronics

Largest Supplier of Electrical and Electronic Components

Click to view similar products for [MOSFET](#) category:

Click to view products by [Winsok](#) manufacturer:

Other Similar products are found below :

[IRFD120](#) [JANTX2N5237](#) [BUK455-60A/B](#) [MIC4420CM-TR](#) [VN1206L](#) [NDP4060](#) [SI4482DY](#) [IPS70R2K0CEAKMA1](#) [SQD23N06-31L-GE3](#)
[TK16J60W,S1VQ\(O](#) [2SK2614\(TE16L1,Q\)](#) [DMN1017UCP3-7](#) [DMN1053UCP4-7](#) [SQJ469EP-T1-GE3](#) [NTE2384](#) [DMC2700UDMQ-7](#)
[DMN2080UCB4-7](#) [DMN61D9UWQ-13](#) [US6M2GTR](#) [DMN31D5UDJ-7](#) [DMP22D4UFO-7B](#) [DMN1006UCA6-7](#) [DMN16M9UCA6-7](#)
[STF5N65M6](#) [IRF40H233XTMA1](#) [STU5N65M6](#) [DMN6022SSD-13](#) [DMN13M9UCA6-7](#) [DMTH10H4M6SPS-13](#) [DMN2990UFB-7B](#)
[IPB80P04P405ATMA2](#) [2N7002W-G](#) [MCAC30N06Y-TP](#) [MCQ7328-TP](#) [NTMC083NP10M5L](#) [NVMFS2D3P04M8LT1G](#) [BXP7N65D](#)
[BXP4N65F](#) [AOL1454G](#) [WMJ80N60C4](#) [BXP2N20L](#) [BXP2N65D](#) [BXT1150N10J](#) [BXT1700P06M](#) [TSM60NB380CP](#) [ROG](#) [RQ7L055BGTCR](#)
[DMNH15H110SK3-13](#) [SLF10N65ABV2](#) [BSO203SP](#) [BSO211P](#)